

**INVESTIGATION OF CATALYTIC PROPERTIES  
OF HUMAN IRE1 $\alpha$ p IN YEAST MODEL**

**PATTARAWUT SOPHA**

**A THESIS SUBMITTED IN PARTIAL FULFILLMENT  
OF THE REQUIREMENTS FOR  
THE DEGREE OF MASTER OF SCIENCE  
(MOLECULAR GENETICS AND GENETIC ENGINEERING)  
FACULTY OF GRADUATE STUDIES  
MAHIDOL UNIVERSITY  
2005**

**ISBN 974-04-5712-6**

**COPYRIGHT OF MAHIDOL UNIVERSITY**

Thesis  
Entitled

**INVESTIGATION OF CATALYTIC PROPERTIES  
OF HUMAN IRE1 $\alpha$ p IN YEAST MODEL**

.....  
Mr. Pattarawut Sopha  
Candidate

.....  
Lect. Witoon Tirasophon, Ph.D.  
Major-Advisor

.....  
Asst. Prof. Varaporn Akkarapatumwong,  
Ph.D.  
Co-Advisor

.....  
Asst. Prof. Lily Eurwilaichitr, Ph.D.  
Co-Advisor

.....  
Assoc. Prof. Rassmidara Hoonsawat,  
Ph.D.  
Dean  
Faculty of Graduate Studies

.....  
Asst. Prof. Varaporn Akkarapatumwong,  
Ph.D.  
Chair  
Master of Science Programme in Molecular  
Genetics and Genetic Engineering  
Institute of Molecular Biology and Genetics

Thesis  
Entitled

**INVESTIGATION OF CATALYTIC PROPERTIES  
OF HUMAN IRE1 $\alpha$ p IN YEAST MODEL**

was submitted to the Faculty of Graduate Studies, Mahidol University  
for the Degree of Master of Science (Molecular Genetics and Genetic Engineering)

on

March 17, 2005

.....  
Mr. Pattarawut Sopha  
Candidate

.....  
Lect. Witoon Tirasophon, Ph.D.  
Chair

.....  
Asst. Prof. Varaporn Akkarapatumwong,  
Ph.D.  
Member

.....  
Asst. Prof. Sutipa Tanapongpipat, Ph.D.  
Member

.....  
Asst. Prof. Lily Eurwilaichitr, Ph.D.  
Member

.....  
Assoc. Prof. Rassmidara Hoonsawat,  
Ph.D.  
Dean  
Faculty of Graduate Studies  
Mahidol University

.....  
Asst. Prof. Chartchai Krittanai, Ph.D.  
Acting Director  
Institute of Molecular Biology and Genetics  
Mahidol University

## ACKNOWLEDGEMENTS

I extremely express appreciation to my advisor, Dr. Witoon Tirasophon. With his exhortation and solicitous, this thesis work can be plenarily accomplished. I would like to say thank you very much for everything that he gives me not only the financial support but also the scientific notion and perception.

I would like to acknowledge my thesis committee, Dr. Lily Eurwilaichitr for generous providing me pYEX-PL and pTB326 plasmid and Dr. Varaporn Akkarapratumwong for critical suggestion in PCR detection and Southern blotting analysis.

I am grateful to Mr. Wanlop Chinnirunwong for his technical support, Miss Supattra Treeratrakul for Zeocin™ reagent, Miss Nongluk Plongthongkum and Miss Pattama Wiriyasermkul for sharing in laboratory experiences and other members of intracellular signaling laboratory and all IMBG members for helpfulness.

I tender thanks Dr. Parin Chaivisutarnkul and Dr. Prawat Aungprapapornchai. The world of science is extraordinarily allured as you told. Only this subject I dedicated for. I would like to say thank you to my father, mother and the diehard friends for your money, encouragement and expectation.

I would like to thank to several financial supports that I received from many sources, The Royal Bangkok Sport Club (RBSC) Postgraduate Scholarship Program, Thailand Research Fund (TRF) grant to Prof. Sakol Panyim and The Pfizer Foundation Scholarship.

## INVESTIGATION OF CATALYTIC PROPERTIES OF HUMAN IRE1 $\alpha$ p IN YEAST MODEL

PATTARAWUT SOPHA 4536660 MBMG/M

M.Sc. (MOLECULAR GENETICS AND GENETIC ENGINEERING)

THESIS ADVISORS : WITON TIRASOPHON, Ph.D.,  
VARAPORN AKKARAPATUMWONG, Ph.D., LILY EURWILAICHITR, Ph.D.

### ABSTRACT

The unfolded protein response (UPR) is a highly conserved intracellular signaling pathway required for stress alleviation caused by unfolded protein accumulation in endoplasmic reticulum (ER) lumen. The key step for UPR activation is mediated by an unusual splicing of mRNA encoding transcription factor Hac1p that specifically binds to a 22 bp cis-acting element, UPRE in the promoter of UPR responsive genes. *HAC1* RNA splicing is initiated by specific cleavage via endonuclease activity of Ire1p at its intron/exon junction. Then the exons are joined by tRNA ligase enzyme prior to being translated into a potent transcription factor. The specific seven nucleotide ring stem loop structure as well as several conserved nucleotides presented in both 5' and 3' splice junctions of *HAC1* mRNA are essential for the splicing reaction.

Using the well characterized yeast UPR as a model for elucidating the specific activity of human Ire1 $\alpha$ p, we discovered that the homologous splicing mechanism mediated by human Ire1 $\alpha$ p is not identical to that of yeast. Compared to the endogenous mechanism in the yeast, a more restricted nucleotide sequence at +1 position in the seven nucleotide stem loop structure at the spliced junction in the RNA substrate is pivotal for the RNA splicing mediated by Ire1 $\alpha$ p. By *in vitro* cleavage assay, substitution of adenine with cytosine nucleotide at the +1 position in the stem loop of *HAC1* RNA facilitated the specific cleavage of modified 3' splice site of *HAC1* RNA by hIre1 $\alpha$ p endonuclease. Similar nucleotide restriction of the RNA substrate was observed *in vivo*. Coexpression of hIre1 $\alpha$ p with mutated *HAC1* using yeast strain with *Ire1/hac1* null loci is capable of restoring the unconventional RNA splicing as well as the specific transcriptional up-regulation of UPR reporter gene upon ER stress whereas coexpression of hIre1 $\alpha$ p with wild type *HAC1* failed to rescue this pathway. Together these results underline the role of cytosine nucleotide at +1 of *HAC1* 3' splice junction as a critical residue that determines the specificity of hIre1 $\alpha$ p mediated mRNA splicing process.

KEY WORDS: hIRE1 $\alpha$ p/ SEVEN NUCLEOTIDE STEM-LOOP STRUCTURE/  
UNCONVENTIONAL SPLICING/ UPR/ HAC1

100 P. ISBN 974-04-5712-6

การศึกษาคุณสมบัติการเร่งปฏิกิริยาของโปรตีน IRE1 $\alpha$ p ของมนุษย์ภายในยีสต์ (INVESTIGATION OF CATALYTIC PROPERTIES OF HUMAN IRE1 $\alpha$ p IN YEAST MODEL)

ภัทรารุช โสภกา 4536660 MBMG/M

วท.ม. (อนุพันธุศาสตร์และพันธุวิศวกรรมศาสตร์)

คณะกรรมการควบคุมวิทยานิพนธ์ : วิฑูรย์ ธิระโสภณ, Ph.D., วราภรณ์ อัครปทุมวงศ์, Ph.D., ลีลี่ เอื้อวิไลจิตร, Ph.D.

บทคัดย่อ

Unfolded protein response (UPR) เป็นกลไกการตอบสนองต่อภาวะเครียดที่เกิดจากการสะสมของโปรตีนไม่สามารถม้วนพับได้ถูกต้องภายในเอนโดพลาสมิกเรติคูลัม ซึ่งเป็นกลไกที่พบได้ตั้งแต่ยีสต์จนถึงมนุษย์ ขั้นตอนสำคัญของกลไก UPR คือการกระตุ้นกระบวนการตัดต่อแบบจำเพาะของสารพันธุกรรมอาร์เอ็นเอ (mRNA) ที่ควบคุมการสร้างโปรตีน Hac1p โดยโปรตีนนี้จะจับอย่างจำเพาะต่อโปรโมเตอร์ขนาด 22 คู่เบส (UPRE) เพื่อกระตุ้นการแสดงออกของยีน ซึ่งมีหน้าที่ในการตอบสนองต่อภาวะเครียด กลไกการตัดต่อ *HAC1* mRNA เริ่มต้นจากการทำงานของ endonuclease ของ Ire1p ที่สามารถตัดสาย mRNA ที่รอยต่อระหว่าง intron กับ exon อย่างจำเพาะ จากนั้นชิ้นส่วนของ exon จะถูกเชื่อมต่อเข้าด้วยกันโดยการทำงานของ rRNA ligase ให้อยู่ในรูปที่เหมาะสมแก่การเป็นแม่แบบสำหรับสร้างโปรตีน Hac1p ที่มีคุณสมบัติเป็น transcription factor กระบวนการตัดต่อแบบจำเพาะของสารพันธุกรรมอาร์เอ็นเออาศัยโครงสร้างจำเพาะแบบ stem loop ที่ประกอบด้วย 7 นิวคลีโอไทด์ loop ซึ่งปรากฏที่รอยต่อทั้งสองตำแหน่งของการตัดต่อ

การศึกษานี้อาศัยกระบวนการ UPR ของยีสต์เป็นแบบจำลองเพื่อศึกษาความจำเพาะของกลไกการทำงานของ human Ire1 $\alpha$ p ผลการทดลองพบว่ากลไก UPR ที่ใช้ hIre1 $\alpha$ p มีความแตกต่างบางประการจากกลไกที่มีพบในยีสต์โดยนิวคลีโอไทด์ในตำแหน่ง +1 ของโครงสร้าง stem loop มีความสำคัญต่อกระบวนการตัดสายอาร์เอ็นเอโดย hIre1 $\alpha$ p การเปลี่ยนนิวคลีโอไทด์ตำแหน่งนี้จากอดีนีนเป็นไซโตซีนนั้นส่งผลให้เกิดการตัดสายของ *HAC1* อาร์เอ็นเอในหลอดทดลองโดย endonuclease ของ hIre1 $\alpha$ p ได้นอกจากนั้นการเปลี่ยนแปลงนิวคลีโอไทด์ที่ตำแหน่งดังกล่าวยังบ่งชี้ถึงความจำเพาะที่เกิดภายในเซลล์ด้วย จากการทดลองในยีสต์สายพันธุ์ที่ปราศจากยีน *hac1* และ *ire1* เมื่อถูกบังคับให้แสดงออกยีน *HAC1* กลายพันธุ์และ hIre1 $\alpha$ p พบว่าสามารถกระตุ้นให้เกิดการตัดต่อสาย *HAC1* อาร์เอ็นเอ ตลอดจนสามารถกระตุ้นการแสดงออกของยีนที่ตอบสนองต่อ UPR ด้วย ในขณะที่การบังคับให้แสดงออก *HAC1* ที่ไม่กลายพันธุ์ กับ hIRE1 $\alpha$ p นั้นไม่สามารถชดเชยกลไกดังกล่าวภายในเซลล์ ดังนั้นผลทั้งหมดบ่งบอกถึงความสำคัญของไซโตซีนในตำแหน่ง +1 ของ stem loop ด้านรอยต่อ 3' ว่าเป็นตัวกำหนดความจำเพาะของสายอาร์เอ็นเอต่อการตัดโดย hIre1 $\alpha$ p

100 หน้า ISBN 974-04-5712-6

# CONTENTS

	<b>Page</b>
<b>ACKNOWLEDGEMENTS</b>	iii
<b>ABSTRACT</b>	iv
<b>LIST OF TABLES</b>	x
<b>LIST OF FIGURES</b>	xi
<b>LIST OF ABBREVIATIONS</b>	xiii
<b>CHAPTER</b>	
<b>1 INTRODUCTION</b>	1
1.1 Protein	1
1.2 Endoplasmic Reticulum	1
1.2.1 Protein folding in endoplasmic reticulum	2
1.2.2 Endoplasmic reticulum stress	2
1.3 Unfolded Protein Response in yeast	3
1.4 An unconventional splicing of <i>HAC1</i> mRNA by Ire1p	8
1.5 ER stress response in mammalian cell	11
1.6 Mammalian Ire1p	13
<b>2 OBJECTIVE</b>	15
<b>3 MATERIALS</b>	16
3.1 Chemical substances	16
3.2 Enzymes	16
3.3 Miscellaneous materials	16
3.4 Bacterial strain	17
3.5 Yeast strains	17
3.6 Plasmid vectors	19

## CONTENTS (CONT.)

	<b>Page</b>
3.6.1 Bacterial plasmid	19
3.6.2 Yeast plasmid	19
3.6.3 Mammalian expression plasmid	19
3.7 Culture media	19
3.7.1 Bacterial culture media (for plasmid propagation)	19
3.7.2 Bacterial culture media (for <i>E. coli</i> competent cell preparation)	19
3.7.3 Yeast culture medium	19
3.7.4 Mammalian cell culture medium	25
3.8 Primer and oligonucleotide	25
3.9 Computer software	25
<b>4 METHODS</b>	<b>30</b>
4.1 <i>in vitro</i> cleavage of <i>HACI</i> RNA by hIre1 $\alpha$ p	30
4.1.1 Site-directed mutagenesis	30
4.1.2 <i>in vitro</i> transcription of <i>HACI</i> RNA	30
4.1.3 hIre1 $\alpha$ p expression and immunoprecipitation	31
4.1.4 Cleavage of labeled <i>HACI</i> RNA by hIre1 $\alpha$ p	32
4.2 Cloning and manipulation of <i>HACI</i> gene	32
4.2.1 The <i>E. coli</i> competent cell preparation and transformation by heat shock	33
4.2.2 Recombinant <i>E. coli</i> clones screening	37
4.2.3 Plasmid DNA extraction by alkaline lysis method	37
4.2.4 Purification of plasmid DNA using QIAprep spin Miniprep kit	37
4.2.5 Restriction enzyme digestion analysis of recombinant clones	38
4.2.6 DNA sequencing	38

## CONTENTS (CONT.)

	<b>Page</b>
4.3 <i>Δhac1/Δire1</i> double deleting strain construction	38
4.3.1 PCR amplification of <i>hac1::zeocin</i> expression cassette	38
4.3.2 <i>S. cerevisiae</i> transformation with <i>hac1::zeocin</i> cassette	38
4.3.3 PCR detection of overlap fragment of <i>hac1::zeocin</i> cassette of putative <i>Δhac1/Δire1</i> strain	39
4.3.4 Southern blot analysis	39
4.4 β-galactosidase assay	41
4.5 Reverse Transcription-Polymerase chain reaction	42
4.5.1 RNA extraction	42
4.5.2 First strand cDNA synthesis	43
4.5.3 PCR detection of <i>HAC1</i> , <i>KAR2</i> and <i>ACT1</i> gene	43
4.6 Northern blotting	43
<b>5 RESULTS</b>	<b>45</b>
5.1 UPR complementation in <i>S. cerevisiae</i> AWY19 by hIre1 $\alpha$ p	45
5.2 Site-directed mutagenesis of <i>HAC1</i> gene	47
5.3 <i>in vitro</i> cleavage of <i>HAC1</i> RNA by hIre1 $\alpha$ p	47
5.4 Target disruption of <i>HAC1</i> endogenous locus	51
5.4.1 PCR amplification of <i>hac1::zeocin</i> expression cassette	51
5.4.2 <i>hac1::zeocin</i> expression cassette transformation	51
5.4.3 UPR characterization of <i>Δhac1/Δire1</i> strain	57
5.5 Construction of recombinant plasmid expressing wild type and mutant <i>HAC1</i>	60
5.6 RT-PCR detection of mutated <i>HAC1</i> splicing	66

**CONTENTS (CONT.)**

	<b>Page</b>
5.7 The northern blot analysis for <i>HAC1</i> splicing detection	68
5.8 UPR induction in $\Delta hac1/\Delta ire1$ strain with mutated <i>HAC1</i> and hIre1 $\alpha$ p	68
<b>6 DISCUSSION</b>	72
<b>7 CONCLUSION</b>	77
<b>REFERENCES</b>	78
<b>BIOGRAPHY</b>	85

## LIST OF TABLES

<b>Table</b>		<b>Page</b>
1	Yeast strains and their genotypes used in this study	18
2	Synthetic defined medium used in the study	26
3	10X amino acid table	27
4	List of oligonucleotide primers	28
5	PCR profile and reaction composition	34
6	Media testing of $\Delta ire1/\Delta hac1$ strain	59

## LIST OF FIGURES

Figure	Page
1 Ire1p domain organization	4
2 Schematic of <i>S. cerevisiae</i> UPR	7
3 The predicted secondary structure of intron in <i>HAC1<sup>u</sup></i> mRNA	9
4 The seven nucleotides stem-loop structure at the spliced junction of <i>HAC1</i> mRNA	10
5 Sequences comparison of 5' and 3' splice junction <i>S. cerevisiae HAC1</i> and <i>XBP-1</i> from several organisms	12
6 Physical map of pBluescript- <i>HAC1b</i>	20
7 Physical map of pYES2	21
8 Physical map of pPICZ $\alpha$ A	22
9 Physical map of pTB326	23
10 Physical map of pED- <i>hIRE1<math>\alpha</math></i>	24
11 Activation of UPR in <i>ire1</i> null <i>S. cerevisiae</i> , AWY19, by plasmid derived Ire1p	46
12 The alignment of candidate mutated pBluescript- <i>HAC1b</i> clones	48
13 <i>in vitro</i> cleavage of wild type or mutated <i>HAC1</i> fragment with hIre1 $\alpha$ p	50
14 PCR amplification of Zeocin <sup>TM</sup> expression cassette	52
15 Target disruption of the endogenous <i>HAC1</i> gene by Zeocin <sup>TM</sup> expression cassette	54
16 Confirmation of $\Delta$ <i>hac1</i> / $\Delta$ <i>ire1</i> double mutations by determination the presence of overlap <i>HAC1</i> -Zeocin fragment by using PCR	55
17 Confirmation of $\Delta$ <i>hac1</i> / $\Delta$ <i>ire1</i> by southern blotting	56
18 $\beta$ -galactosidase assay of expected $\Delta$ <i>ire1</i> / $\Delta$ <i>hac1</i> yeast strains	58

**LIST OF FIGURES (CONT.)**

<b>Figure</b>		<b>Page</b>
19	PCR amplification of wild type <i>HAC1</i> gene from <i>S. cerevisiae</i>	61
20	3'UTR of <i>HAC1</i> amplification	62
21	Physical map of pTB- <i>HAC1</i>	63
22	Physical map of pTB-MTHAC1	64
23	The 1.9 kb <i>HAC1</i> gene in pTB plasmid characterization	65
24	RT-PCR detection of <i>HAC1</i> RNA splicing	67
25	Northern blotting for <i>HAC1</i> mRNA detection of mutated <i>HAC1</i>	69
26	$\beta$ -galactosidase assay of mutated <i>HAC1</i>	71

## LIST OF ABBREVIATIONS

A <sub>260</sub>	=	absorbance at 260 nm
A <sub>280</sub>	=	absorbance at 280 nm
APS	=	ammonium persulphate
ATP	=	adenosine-5'-triphosphate
bp	=	base pair(s)
°C	=	degree Celcius
cDNA	=	complementary DNA
Ci	=	Curie
CTP	=	cytidine-5'-triphosphate
dATP	=	deoxyadenosine-5'-triphosphate
dCTP	=	deoxycytosine-5'-triphosphate
dGTP	=	deoxyguanosine-5'-triphosphate
dTTP	=	deoxythymidine-5'-triphosphate
dNTPs	=	dATP, dCTP, dGTP and dTTP
DEPC	=	diethyl pyrocarbonate
DIG-11-dUTP	=	digoxigenin-11-2'-deoxyuridine-5'-triphosphate
DMEM	=	Dulbeco's modified eagle medium
DMSO	=	dimethyl sulfoxide
DNA	=	deoxyribonucleic acid
DTT	=	dithiothreitol
EDTA	=	ethylene diamine tetraacetic acid
EtBr	=	ethidium bromide
<i>E. coli</i>	=	<i>Escherichia coli</i>
FBS	=	fetal bovine serum
g	=	gram(s)
GTP	=	gaunosine-5'-triphosphate
hr	=	hour(s)

**LIST OF ABBREVIATIONS (CONT.)**

IPTG	=	isopropyl- $\beta$ - <i>D</i> -thiogalactopyranoside
kb	=	kilobase(s)
kDa	=	kilodalton(s)
LB	=	Luria-Bertani (medium)
M	=	molar
mM	=	millimolar
mg	=	milligram(s)
min	=	minute(s)
ml	=	milliliter(s)
$\mu$ g	=	microgram(s)
$\mu$ l	=	microliter(s)
$\mu$ M	=	micromolar
mRNA	=	messenger RNA
ng	=	nanogram(s)
nt	=	nucleotide(s)
OD	=	optical density
ONPG	=	<i>O</i> -nitrophenyl- $\beta$ - <i>D</i> -galactopyranoside
PAGE	=	polyacrylamide gel electrophoresis
PCR	=	polymerase chain reaction
PIPES	=	piperazine-1,4-bis [2-ethanesulfonic acid]
pmole	=	picomole
PMSF	=	phenylmethylsulfonyl fluoride
rATP	=	riboadenosine-5'-triphosphate
rCTP	=	ribocytosine-5'-triphosphate
rGTP	=	riboguanosine-5'-triphosphate
rUTP	=	ribouridine-5'-triphosphate
rNTP	=	ribonucleotide triphosphate
RNA	=	ribonucleic acid
RNase A	=	ribonuclease A

**LIST OF ABBREVIATIONS (CONT.)**

RNasin	=	RNase inhibitor
rpm	=	revolution per minute
RT-PCR	=	reverse transcription-polymerase chain reaction
SDS	=	sodium dodecyl sulfate
sec	=	second(s)
T <sub>m</sub>	=	melting temperature
TAE	=	Tris-acetate EDTA
TBE	=	Tris-borate EDTA
TEMED	=	N,N,N',N'-tetramethyl-ethylenediamine
Tris-HCl	=	tris-(hydroxymethyl)-aminoethane hydrochloric acid
TTP	=	thymidine-5'-triphosphate
U	=	unit
UV	=	ultraviolet
V	=	volt(s)
v/v	=	volume/volume
w/v	=	weight/volume
X-gal	=	5-bromo-4-chloro-3-indolyl- $\beta$ -D- galactopyranoside
%	=	per cent

# CHAPTER 1

## INTRODUCTION

### 1.1 Protein

Proteins are the most bounteous biological macromolecule in which they are found in all types and compartments of cell. Proteins exert variety architectures and functions underlining the importance of protein in cellular activities. Protein is a biopolymer of amino acid in which biosynthesis happens in all living cells. In order to function, the long polypeptide chain must be folded into its proper tertiary structure. Only the properly folded protein can perform its task. Accumulating information from numerous studies describe the relationship between diseases and protein misfolding (1, 2, 3). While folding of proteins destined to cytoplasm, peroxisomes, nucleus and mitochondria takes place in cytoplasm, the folding processes of secreted and membrane protein in eukaryotic cell are occurred in endoplasmic reticulum (ER) (4, 5, 6, 7). Therefore, ER is the organelle in the cells that highly susceptible for condition that leads to protein malfolding. Many chemical reagents as well as physiological condition in development stage can disturb the folding dynamic in ER (2).

### 1.2 Endoplasmic Reticulum

Endoplasmic reticulum (ER) is a network of membrane-bound sac and tubules extending from inner nuclear membrane which is common in all eukaryotic cells. In most cells, ER could be divided into two types according to their microscopic appearance, rough ER (RER) and smooth ER (SER). The major difference among the two is that RER contains ribosome in which is being engaged in the translating secreted or membrane proteins. SER, on the other hand, lack of membrane-bound ribosome, is involved in phospholipids and membrane biosynthesis (4-7).

### 1.2.1 Protein folding in endoplasmic reticulum

Secreted and membrane proteins must be translocated through ER using signal peptide presence on their amino termini as an entry signal. There are two ways for protein movement through ER, cotranslational and posttranslational translocation. The posttranslational translocation allows translation process to be completed in cytoplasm prior to transferring into the ER. In contrast, co-translational translocation process is referred to simultaneous reactions of protein translation and protein loading to the ER (5).

ER lumen contains various protein-processing molecular chaperones and folding enzymes such as GRP78/BiP or Kar2p in yeast (8, 9), Protein disulphide isomerase (Pdi1p) (10), *cis-trans* prolyl isomerase (Fkb2p) (11), a PDI-like protein (Eug1p) (12) and DnaJ homologue (Scj1p) (13). All these ER resident molecules work cooperatively to help the newly synthesized proteins fold into their proper tertiary structures. Moreover, ER is considered as quality control organelle for protein folding. Only the properly folded proteins are permitted exit and resume their trafficking route. From this notion, it is believed that environment in ER lumen must be consistently adjusted in order to maintain its homeostasis. Beside its major task in providing condition for protein folding, ER is also the primary organelle for protein modification process particularly N-linked glycosylation. Many passenger proteins received carbohydrate modification in the ER at asparagine (Asn) residue within conserved sequences Asn-X-Ser/Thr. The glycosylation is directly involved in promoting protein folding of many proteins by cooperative actions of specific molecular chaperones. Whereas, in other cases, this modification helps to prolong the half-life of certain proteins in blood circulation (4-7).

### 1.2.2 Endoplasmic reticulum stress

ER status is highly dynamic. While the newly synthesized proteins are constantly loaded into ER for folding, the correctly folded proteins are continually expunged from the ER. As a result, cellular homeostasis must be closely monitored in order to maintain this equilibrium. However in some circumstances, ER homeostasis could be severely disturbed such as in cell with hyper activity caused increasing demand in capacity of protein folding. This condition is found in developmental stage

of certain stage of cells such as during B-cell differentiation or neuron hyperresponse (14, 15). Certain chemicals exhibit pharmacological action leading to physiological changing that strongly perturbs ER homeostasis. For example, Thapsigargin is an inhibitor  $\text{Ca}^{2+}$ -ATPase at ER membrane, Dithiotretol (DTT) and  $\beta$ -mercaptoethanol are reducing agents that prohibit disulfide bond formation and tunicamycin, N-linked glycosylation blocker. Exposure to these agents directly or indirectly interferes protein folding in the ER hence the proteins are accumulated in the ER in unfolded or misfolded stage (16-18). Such accumulation is termed ER stress. The stress seriously harms the cell in many aspects, for example overall protein synthesis is inhibited, cellular activities are being halted as well as it triggers apoptotic pathway in these cells (19).

To survive from ER stress, eukaryotic cells have evolved an elaborate mechanism. Logically, under ER stress, cell attempts to elevate the level of folding enzymes or chaperones in the ER to match their demand by sending signal to activate transcription of ER-resident protein genes such as *PDII*, *EUG1* and *FKB2* in the nucleus (20). The mechanism of gene induction in response to ER stress is termed Unfolded Protein Response (UPR).

### 1.3 Unfolded Protein Response in yeast

The power of genetic screening in *Saccharomyces cerevisiae* attributes to a great success in identification of gene relating in ER stress response pathway that allows scientists to explore the mechanism by which this model organism employs to initiate transcriptional induction of ER-resident protein genes during ER stress (17).

Initial investigation revealed the connection between mutation in *IRE1* gene and the utter loss of ER stress response (10, 21). The product of *IRE1* gene, Ire1p, is a type I membrane protein with functional serine/threonine kinase domain making it resembled to protein kinase receptor of higher eukaryotic cells (Figure 1). Ire1p was previously identified as a gene that involves in inositol metabolism in yeast implying a connection of UPR to membrane production in yeast (22). Subsequent studies suggested that Ire1p served as a sensor to sense the accumulation of unfolded protein by monitoring the level of free BiP in this organelle. N-terminal domain of Ire1p

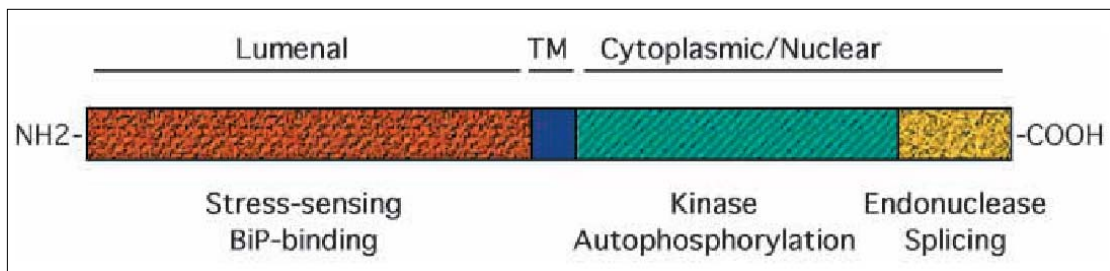

### Figure 1 Ire1p domain organization

Ire1p is a type I transmembrane protein that possesses both kinase and endonuclease activity. The N-terminal domain of Ire1p (red) is protruded in ER lumen and this domain specifically bound with BiP. The binding or releasing of BiP is the mechanism for stress sensing. Ire1p contains a single transmembrane domain, TM (blue). Cytoplasmic or nuclear domain of Ire1p has enzymatic function both kinase (green) and endonuclease (yellow). (Modified from Urano, F., *et al.* 2000 (26)).

capable of interacting with free BiP that helps them to remain in monomeric inactive stage in non-stress condition (23-25). In contrast, during ER stress BiP dissociated from Ire1p and bind to unfolded protein allowing Ire1p to form homodimer/oligomer. Such configuration allows allosteric change in Ire1p's architecture and elicits its intrinsic kinase properties to initiate trans-autophosphorylation. This intrinsic kinase is essential of Ire1p to relay the signal for UPR activation (27-29). On the contrary, phosphorylated Ire1p can be down regulated by dephosphorylation by phosphatase Ptc2p, a type 2C serine/threonine phosphatase, to resume to inactive stage once the stress is coped. Yeast strain devoid of *PTC2* gene exhibited high basal level of UPR activity whereas over-expression of Ptc2p reduced the magnitude of UPR activation compared to that of wild type. These evidents support the role of Ptc2p as a negative regulator of Ire1p (30).

In addition to the kinase activity, Ire1p also exhibits site specific endoribonuclease activity (31). Although they exhibit difference in mechanistic of action, the two catalytic activities are entwined. Previous experiments underline the influent of kinase activity on endoribonuclease domain regulation, debilitated kinase domain leading to loss of endoribonuclease function and the process occurs as a sequential event from kinase activating to endoribonuclease induction (29). The only known substrate of Ire1p, is *HAC1* mRNA whose product, Hac1p, is a pivotal component in the UPR pathway lined downstream to Ire1p. Likewise, the role of Hac1p was received from UPR loss-of-function in *HAC1*-null yeast strain (32-34).

In early stage, the connection between *IRE1* and *HAC1* was unclear. The phenotype of *ire1* and *hac1* deleting yeast strain were the same. The striking observation by Cox *et al.* (32) demonstrated that the expression pattern of *HAC1* mRNA sequence was not identical to general mRNA. *HAC1* mRNA detected under ER stress appeared smaller than obtained from normal growing condition resulting from the loss of 252 nt close to the 3' end of its open reading frame (32). This finding prompted them to investigate the possibility that endoribonuclease activity of Ire1p might involve in such alteration. Using bacterially expressed Ire1p to incubate with radioactive-labeled *in vitro* transcribed *HAC1* RNA, Sidrauski *et al.* (31) was the first group who successfully showed that Ire1p efficiently cleaved *HAC1* RNA to generate specific pattern of *HAC1* RNA fragments *in vitro*. Together with primer extension to

map the position by which Ire1p mediated *HAC1* cleavage are correspond to that of exon/intron splicing junction on *HAC1* mRNA observed *in vivo* supporting the notion that this stress specific splicing reaction requires Ire1p function (32, 35).

The mode of regulation of *HAC1* is unusual (32, 36). In normal growing condition, *HAC1* gene was constitutively expressed generating *HAC1* mRNA containing 252 nt intron *HAC1<sup>u</sup>* referred as uninduced *HAC1*. Surprisingly, no protein product was detected from this mRNA. In contrast, during ER stress, the spliceosome-independent, unconventionally *HAC1* mRNA splicing is take places, however, it requires on Ire1p endoribonuclease and tRNA ligase activity (37). The splicing generates an intronless species of *HAC1* mRNA, *HAC1<sup>i</sup>*, referred as induced *HAC1*. The predicted open reading frame of *HAC1<sup>u</sup>* encoding 230 amino acid residues, whereas the spliced *HAC1<sup>i</sup>* mRNA encodes protein with 238 amino acid residues. While the majority of the predicted polypeptide sequence was identical between the two species, the splicing caused frame-shift of translation that alter the last 10 amino acid residues at the C terminus of *HAC1<sup>u</sup>* with 18 new amino acids in *HAC1<sup>i</sup>* coding sequences (32, 36, 38). The half-life of Hac1p<sup>i</sup> is about 1-2 minutes indicating that the protein is not stable. This could be due to the presence of PEST (Pro, Glu, Ser, Thr rich) sequences at C terminal (32). The 252 nt intron present in *HAC1<sup>u</sup>* mRNA potentially attenuate the translation of this mRNA might explain why the protein product from this mRNA was not detected in non stress condition (39). *HAC1<sup>i</sup>* mRNA is actively translated to Hac1p<sup>i</sup> which is a basic-leucine zipper transcription factor.

Among several UPR target genes, the transcriptional regulatory unit of *KAR2* gene is the best characterized (8, 9, 40, 41, 42). The promoter of *KAR2* gene contains three regions influent its transcription activity: high basal level GC-rich region, Heat Shock Element (HSE) and a 22-bp *cis*-acting element known as Unfolded Protein Response Element (UPRE) were identified and showed that three regions work independently (41). Of these elements, UPRE was identified as the element that directs transcription up-regulation during ER stress (41). When fused with *CYCI* crippled promoter of reporter gene, it turns this reporter gene to response to unfolded protein accumulation condition (10, 32, 41). To further characterize the UPRE element, mutagenesis was performed in order to determine the critical nucleotide residues in the

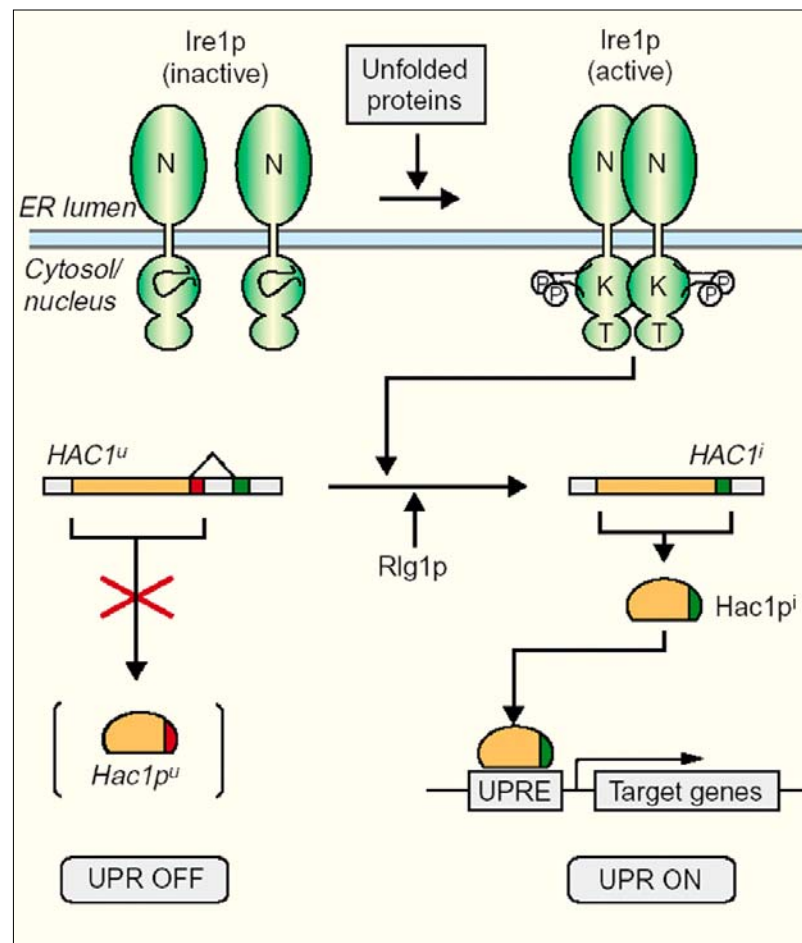

**Figure 2 Schematic of *S. cerevisiae* UPR**

Ire1p senses the accumulation of unfolded protein in ER lumen by release BiP from N terminal domain (N), then trans-autophosphorylation by kinase action (K) and activates its endonuclease (T). The substrate for Ire1p endonuclease is constitutive expressed *HAC1<sup>u</sup>* mRNA. Subsequence to the cleavage at exon/intron boundaries, the *HAC1* exons are joined together by tRNA ligase (Rlg1p) to produce *HAC1<sup>i</sup>* encoding active transcription factor, Hac1<sup>pi</sup>. The target of Hac1<sup>pi</sup> is the 22 bp cis-acting element UPRE located at promoter of ER-resident chaperone protein genes. The red area indicated the first stop codon region which can be translated to 10 amino acids. The green area indicated the second stop codon region which 18 amino acids are included in C-terminal of Hac1<sup>pi</sup>. (Adapted from Patil, C. and Walter, P. 2001 (43))

promoter context. Interestingly, the partial palindromic sequence with a single nucleotide spacer of CAGCGTG was identified as the core element of the UPRE (41, 42). This sequence is similar to E-box sequences. Moreover, electrophoretic mobility shift assay of UPRE-Hac1p demonstrated the specific binding between Hac1p to 22-bp UPRE sequences (36, 41).

#### **1.4 An unconventional splicing of *HAC1* mRNA by Ire1p**

The interesting distinctive of UPR is the unconventional splicing of mRNA encoding a transcription factor for ER chaperone gene induction, *HAC1*, by receptor protein. The splicing mechanism is somewhat unusual. It does not require the large ribonucleoprotein spliceosome complex, which is involved in pre-mRNA splicing. And also the exon/intron junction sequence of *HAC1* mRNA is differed from common pre-mRNA. These attributes promote this pathway unique over common splicing event of eukaryotic cell (4-7).

The most important characteristic underlining the unique of Ire1p mediated splicing reaction is the seven nucleotide stem-loop structure on the *HAC1* mRNAs molecule which were recognized and precisely cleaved by activated Ire1p endonuclease (Figure 4) (44). Beside the conserved structure, nucleotide sequences within the loop also play a major contribution to cleavage specificity by Ire1p (Figure 3) (44). Previous experiment in yeast *HAC1* indicated that the nucleotide at position -3, -1, +3 and +5 relative to the cleaved site at both 5' and 3' splice junction are required for splicing activity by Ire1p (44). The mutation in these positions inhibited splicing during the stress. The synthetic mini stem-loop substrates resembling the *HAC1* mRNA seven nucleotide stem-loops are also susceptible to Ire1p endonuclease implying that the seven nucleotide loop structure contain all crucial features to mediate the splicing.

The procedure of unconventional mRNA splicing also identified in mammalian cell. To date the only identified RNA regulated by this pathway is *XBP-1* mRNA encoding an X-box binding protein transcription factor (45). Similar to *HAC1* RNA splicing, *XBP-1* mRNA is spliced by Ire1p dependent mechanism. Although the mechanistic detail in mammalian UPR is not completely understood, it shares several intriguing conserved features to the yeast UPR. Particularly *XBP-1* mRNA is not

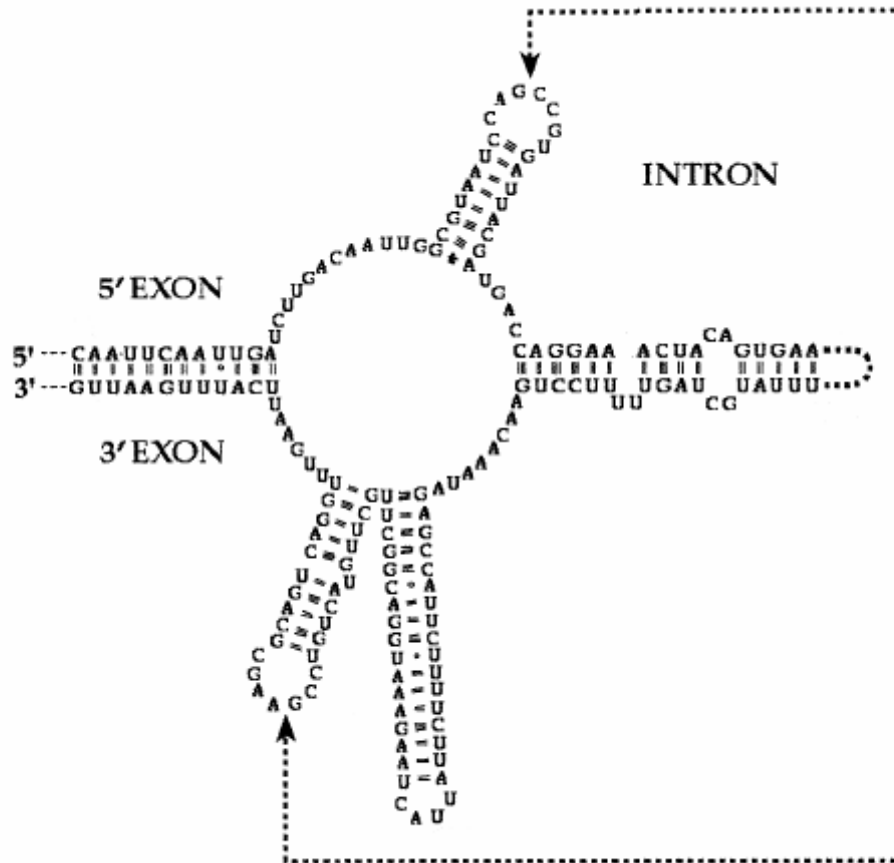

**Figure 3** The predicted secondary structure of intron in *HAC1*<sup>u</sup> mRNA

*HAC1* intron is arranged with both 5' and 3' exon to generate the stem-loop structure. Position of specific cleavage sites by Ire1p endonuclease in the 5' and 3' stem loop structure at exon/intron junctions are indicated as arrows. The 140 omitted nucleotides in intron are representing as dot line. (Adapted from Gonzalez, T., *et al.* 1999 (44)).

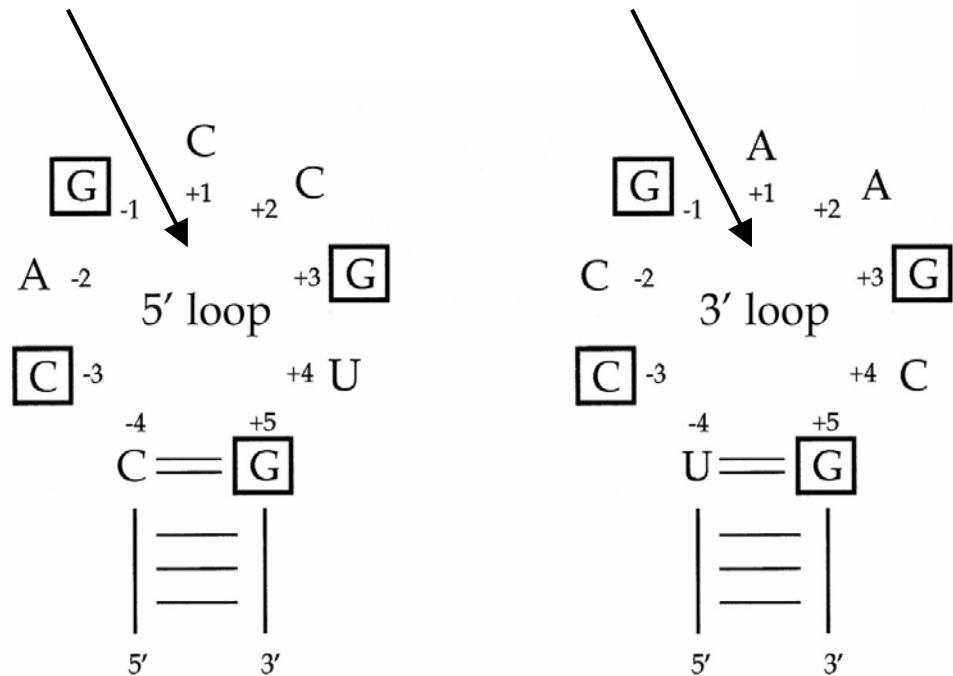

**Figure 4** The seven nucleotide stem-loop structure at the spliced junction of *HAC1* mRNA

The nucleotide sequence in 5' and 3' intron-exon splice junction of *HAC1* mRNA formed loop structure that contained seven nucleotides. The nucleotide positions in the ring are indicated relative to the position of cleavage (the arrows). The nucleotides in box represented the important nucleotides whose mutation will abolished the *HAC1* splicing. (Adapted from Gonzalez, T., *et al.* 1999 (44))

translated into protein unless the cells expose to ER stress. Although overall characteristic of *XBP-1* mRNA was quite different from *HAC1* mRNA, principally, the intron size of *XBP-1* mRNA range from 23 to 26 nt that is spliced out during the stress is markedly smaller than that of *HAC1* RNA (46). Whether the proposed loop structure in *XBP-1* mRNA is sufficient for translation attenuation in non stress cells as found in case of *HAC1* mRNA remains to be investigated. Surprisingly, the stem-loop structure at the spliced junction of *XBP-1* mRNA resembled to those of *HAC1* is highly conserved in multiple organisms such as human, mouse, fruit fly and worm (46-48) (Figure 5). The conserved nucleotide at position -3, -1 and +3 in various organisms *XBP-1* mRNA are dramatically conserved and identical to those found in yeast *HAC1* (46). This observation implies that the stress regulated splicing reaction of these mRNAs may occur through a similar mechanistic detail.

## 1.5 ER stress response in mammalian cell

Mammalian cells response to ER stress in a more complex fashion compared to the yeast cells (18). Multiple modes of actions were employed to cope with the stress including transcriptional up-regulation, translational attenuation as well as apoptosis activation (49, 50). Characterization of BiP and GRP94 promoter manifests the nucleotide region responsible for ER stress transcriptional induction of these genes (51). This region is termed ER stress response element, ERSE. The two elements were identified which shared a common 19-nucleotide sequence motif [CCAAT(N)<sub>9</sub>CCACG] with a GC-rich 9-bp spacer. This indicates mammalian stress response not identical to that found in yeast cell. The transcriptional up-regulation of mammalian UPR responsive genes alone could be mediated through more than one mechanism. One of which utilizes similar mechanism to what described in yeast cell (52). The splicing of transcription factor mRNA was detected in mammalian cell. As difference from yeast, the *HAC1* homologue was not identified but *XBP-1*, another bZIP transcription factor, was proposed to be involved in UPR responsive gene activation. There are many experimental data revealed the *XBP-1* splicing and protein production upon ER stress by the action of Ire1p (45-47).

		5' splice region									
		-5	-4	-3	-2	-1	+1	+2	+3	+4	+5
Yeast	<i>HAC1</i>	U	C	C	A	G	C	C	G	U	G
Human	<i>XBP-1</i>	G	U	C	C	G	C	A	G	C	A
Mouse	<i>XBP-1</i>	G	U	C	C	G	C	A	G	C	A
Fruit fly	<i>XBP-1</i>	A	U	C	U	G	C	A	G	C	A
Rounded worm	<i>XBP-1</i>	A	U	C	A	G	C	A	G	C	A

		3' splice region									
		-5	-4	-3	-2	-1	+1	+2	+3	+4	+5
Yeast	<i>HAC1</i>	G	U	C	C	G	<u>A</u>	A	G	C	G
Human	<i>XBP-1</i>	C	U	C	U	G	C	A	G	C	A
Mouse	<i>XBP-1</i>	C	U	C	U	G	C	A	G	C	A
Fruit fly	<i>XBP-1</i>	C	U	C	U	G	C	C	G	C	A
Rounded worm	<i>XBP-1</i>	C	U	C	A	G	C	A	G	U	G

**Figure 5** Sequences comparison of 5' and 3' splice junction *S.cerevisiae HAC1* and *XBP-1* from several organisms

The nucleotide sequences at 5' and 3' splice junction of *HAC1* of yeast (*S. cerevisiae*) and *XBP-1* from human (*H. sapiens*), mouse (*M. musculus*), fruit fly (*D. melanogaster*) and rounded worm (*C. elegans*) were aligned. The numbers indicated the position in seven nucleotide stem-loop relative to the cleavage site. The grey alphabets at position -3, -1 and +3 are indicated the conserved nucleotide positions in all model organisms. The underline residue indicates the additional nucleotide involved in cleavage specificity of *HAC1* mRNA.

Furthermore, UPR responsive gene induction can be created by using another pathway beside by the Ire1p/*XBP-1* splicing. ATF6 was identified as a transcription factor that, under ER stress, it is processed and binds specifically with ERSE and then initiates the transcriptional induction (45, 53). This finding suggested the additional pathway of UPR transcription factor regulation that ensures mammalian cell to survive under ER stress condition. This evident further emphasizes the important of transcriptional up-regulation of UPR responsive gene in higher eukaryotic cells on their survival under stress condition.

Mammalian cell also developed the strategy for adjust the demand of protein loading to ER lumen coupling with up-regulation of UPR-responsive genes. By inhibit protein synthesis; the ER lumen is not overload by client protein resulting in unfolded protein clearance under ER stress condition. The mechanism for inhibition is phosphorylation at alpha subunit of translational initiation factor, eIF2 $\alpha$ , preventing the recycle of this essential factor for the translational process (46, 50). The cooperation of UPR gene induction, both Ire1p/*XBP-1* splicing and ATF6 processing, and attenuation of protein loading to ER lumen is the efficient method of mammalian cell for ER stress manipulation owing to the complexity in development mammalian cell needs parallel pathway for UPR induction.

## 1.6 Mammalian Ire1p

The advance knowledge of mammalian UPR was generated from the finding of mammalian Ire1p. Moreover, this identification implies the important of Ire1p splicing as a basic event for UPR-responsive gene induction under ER stress which can be commonly found in eukaryotic cell. Two independent groups have identified two similar cDNAs of mammalian *IRE1* homolog. While one of which expressed in all tissue referred as Ire1 $\alpha$ p (29), the other appeared as gastro-intestinal specific protein, Ire1 $\beta$ p (54, 55). Mammalian Ire1p consists of domain architecture similar to those of yeast Ire1p particularly in their kinase and endonuclease domains (Figure 1). Mutation analysis in human Ire1 $\alpha$ p indicated that both kinase and ribonuclease activity are cooperative function to mediate UPR transcription activation by ER stress (29). Unlike yeast UPR, Ire1p-mediated transcription regulation is not essential for UPR response in mammalian cell but it appears to play crucial role in various aspects of

developmental and differentiation process of cells and embryo (29). Based on the *in vivo* data that was described about the ER chaperone gene induction in *IRE $\alpha$ <sup>-/-</sup>* mammalian cell line, it is believed that other ‘crosstalk’ pathway(s) may exist for UPR complementation (50, 55). Nevertheless, the notion that *IRE1a* might be involved in cell development was consolidated from knock out mice whose embryo can not be survived (29, 50).

In early attempt to characterize the endonuclease activity of mammalian Ire1p, *HAC1* mRNA was used as exogenous substrate due to the lack of identified mammalian Ire1p substrate to demonstrate the existence of UPR pathway in mammalian cells (29). Although hIre1 $\alpha$ p can cleave yeast *HAC1* RNA *in vitro*, the pattern of cleaved product is significantly different from the product cleaved by yeast Ire1p. Furthermore, yeast *HAC1* mRNA is not correctly processed in mammalian cell implying that the mechanistic detail utilized by yeast Ire1p and human Ire1p is not identical (29, 49, 56). Interestingly, the controversial results were reported from studies by another group who demonstrated that the splicing of *HAC1* could be mediated by hIre1p in both 5’ and 3’ splice junctions (57).

From this controversial issue, it leads to our hypothesis that there is a certain feature lies within 3’ splice region dictate the specificity of splicing reaction. The nucleotide sequence in addition to those previously described might be a key element to answer this enigma. Alignment of the nucleotide sequences both 5’ and 3’ splice junction of *HAC1* with *XBP-1* reveals that the nucleotide sequences of 3’ splice junction of *HAC1* are highly similar to 5’ splice junction of human *XBP-1*, the actual cleave site by hIre1p, and except that nucleotide flanked the cleaved position are GA in *HAC1* instead of GC in *XBP-1* (Figure 5). Further comparison among all homolog of *XBP-1* mRNA indicated that all of which contains GC nucleotide flanking their cleaved site. From this evident it is possible that the cytosine residue at +1 position in the stem loop structure of Ire1p substrate might determine the specificity for the recognition as well as the cleavage by hIre1p *in vitro* and *in vivo*.

## **CHAPTER 2**

### **OBJECTIVE**

This study aims to elucidate factor on *HAC1* mRNA that influence the ability of human Ire1 $\alpha$ p endonuclease activity to mediate UPR-regulated RNA splicing reaction. This study will take advantage from the information that *HAC1* mRNA can be effectively cleaved only at its 5' spliced junction *in vitro* to design mutant *HAC1* that allows the RNA to be cleaved by human Ire1 $\alpha$ p at both 5' and 3' splice junction. The study will be focus specifically on the adenine nucleotide at +1 position at the 3' spliced junction of *HAC1* RNA whether its conversion to cytosine nucleotide mandates the catalytic specificity of human Ire1 $\alpha$ p both *in vitro* and *in vivo*.

## CHAPTER 3

### MATERIALS

#### 3.1 Chemical substances

All chemical substances used in this experiment were purchased from Fluka (Switzerland), MERCK (Germany), SIGMA (USA).

#### 3.2 Enzymes

<u>Enzyme Name</u>	<u>Company</u>
Calf intestinal-alkaline phosphatase	Promega
ImProm-II™ reverse transcriptase	Promega
<i>Taq</i> DNA polymerase	Promega
T4 DNA ligase	Invitrogen
<i>Pfu</i> DNA polymerase	Promega
All restriction enzymes	Promega

#### 3.3 Miscellaneous materials

<u>Kit or Reagent Name</u>	<u>Company</u>
DNA molecular weight-markerII, digoxigenin labeled	Roche
dNTP (dATP, dCTP, dGTP and dTTP)	Promega
ECL+ Plus	Amersham Biosciences
GENE CLEAN® II kit	Q BIOGENE
Hybond-N	Amersham Biosciences
Hybond-N+	Amersham Biosciences

Lambda DNA/ <i>Hind</i> III digested marker	Promega
Lambda DNA/ <i>Bst</i> EII digested marker	Promega
NTP (ATP, CTP, GTP and UTP)	Promega
QIAprep Miniprep	QIAGEN
RediPrime™II	Amersham Biosciences

### 3.4 Bacterial strain

*Escherichia coli* DH5 $\alpha$  [*supE44*  $\Delta$ *lacU169* ( $\phi$ 80 *lacZ*  $\Delta$ M15) *hsdR17* *recA1* *endA1* *gyrA96* *thi-1* *relA1*] was used as a host for plasmid propagation and manipulation (58).

### 3.5 Yeast Strains

Three strains of *Saccharomyces cerevisiae* were used in this study. The genotype was shown in Table 1. *S. cerevisiae* AWY14 and AWY19 were kindly provided by Dr. Randal J. Kaufman, Department of Biological Chemistry and Howard Hughes Medical Institute, The University of Michigan Medical Center, Ann Arbor, Michigan, USA (Welihinda AA, Kaufman RJ. unpublished data).

*S. cerevisiae* AWY14 was developed from W303-1 strain by introducing *LacZ* expression cassette under the control of UPRE fusing with crippled *CYC1* promoter (24). The expression of this cassette can be induced under ER stress. *S. cerevisiae* AWY19 was modified from *S. cerevisiae* AWY14 strain by interrupting *IRE1* gene with *KanMX* cassette (24). *S. cerevisiae*  $\Delta$ *hac1*/ $\Delta$ *ire1* was created by eliminating *HAC1* gene of AWY19 strain with Zeocin™ expression cassette derived from pPICZ $\alpha$ A.

**Table 1 Yeast strains and their genotypes used in this study**

*S. cerevisiae* AWY14 and AWY19 were developed from W303-1 strain (*ade2-1, can1-100, his3-11,-15, leu2-3,-112, trp1-1, ura3-1*). *S. cerevisiae*  $\Delta hac1/\Delta ire1$  was developed from *S. cerevisiae* AWY19 in this study.

Strain	Genotype	Reference
AWY14	MATa <i>HIS3::UPRE-PCYC1(-178)-LEU2, TRP1::UPRE-PCYC1(-178)-lacZ</i>	(Welihinda AA, Kaufman RJ. unpublished data)
AWY19	MATa <i>HIS3::UPRE-PCYC1(-178)-LEU2, TRP1::UPRE-PCYC1(-178)-lacZ, ire1::KanMX</i>	(Welihinda AA, Kaufman RJ. unpublished data)
$\Delta hac1/\Delta ire1$	MATa <i>HIS3::UPRE-PCYC1(-178)-LEU2, TRP1::UPRE-PCYC1(-178)-lacZ, ire1::KanMX, hac1::PTEF1-PEM7-Zeocin-CYCITT</i>	This study

### 3.6 Plasmid Vectors

#### 3.6.1 Bacterial plasmid

pBluescript-*HAC1b* Tirasophon, W. *et al.* 1998 (29)

#### 3.6.2 Yeast plasmid

pPICZ $\alpha$ A Invitrogen, USA

pTB326 Piyaviriyakul, P. *et al.* 1999 (59)

pYES2 Invitrogen, USA

#### 3.6.3 Mammalian expression plasmid

pED-*hIRE1 $\alpha$*  Tirasophon, W. *et al.* 1998 (29)

### 3.7 Culture media

#### 3.7.1 Bacterial culture media (for plasmid propagation)

Terrific broth (TB) (60): 1.2% (w/v) tryptone, 2.4% (w/v) yeast extract and 0.4% (v/v) glycerol then autoclaved for 15 minutes at 1.05 kg/cm<sup>2</sup>. Sterile solution of KH<sub>2</sub>PO<sub>4</sub> and K<sub>2</sub>HPO<sub>4</sub> was added to final concentration 0.017 M and 0.072 M, respectively. Media was supplemented with ampicillin 50  $\mu$ g/ml for selection of all plasmids.

Luria-Bertani broth (LB) (60) containing 1% (w/v) tryptone, 0.5% (w/v) yeast extract, 1% (w/v) NaCl was adjusted to pH 7.0 with NaOH, then autoclaved (121<sup>0</sup>C, 15 minutes, 1.05 kg/cm<sup>2</sup>). LB agar plate contained similar component as LB broth but including 2% (w/v) agar.

#### 3.7.2 Bacterial culture media (for *E. coli* competent cell preparation)

SOB medium (60) containing 2% (w/v) tryptone, 0.5% (w/v) yeast extract, 0.05% (w/v) NaCl, 2.5 mM KCl, 10 mM MgCl<sub>2</sub> was adjusted to pH 7.0 with NaOH. The mixture solution was autoclaved at 121<sup>0</sup>C, 15 minutes at 1.05 kg/cm<sup>2</sup>.

#### 3.7.3 Yeast culture medium

YEPD media (60) containing 2% (w/v) peptone, 1% (w/v) yeast extract, 2% (w/v) D-glucose and 2% (w/v) agar for YEPD plate. YEPD containing Zeocin<sup>TM</sup> 50  $\mu$ g/ml was used to select *S. cerevisiae*  $\Delta$ *hac1*/ $\Delta$ *ire1*. Minimally synthetic defined mediums were prepared according to selective marker of each plasmid as shown in Table 2.

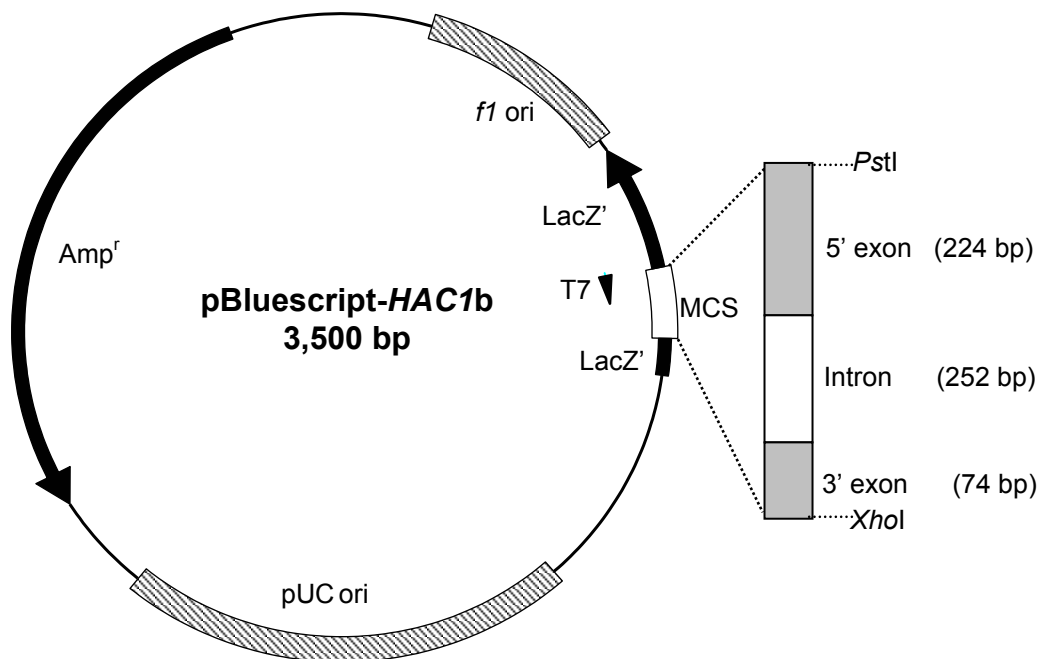

**Multiple Cloning Site Region**

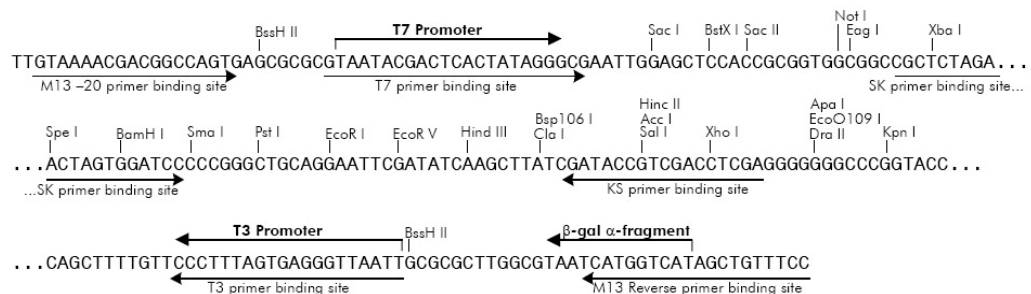

**Figure 6 Physical map of pBluescript-HAC1b**

This plasmid contains ampicillin resistant gene ( $Amp^r$ ), origin of replication derived from pUC plasmid family (pUC ori), *f1* origin of replication (*f1* ori) and T7 promoter (T7). 550 bp of truncated *HAC1* gene including region of 5' exon, intron and 3' exon was inserted to  $\beta$ -galactosidase gene (*LacZ'*).

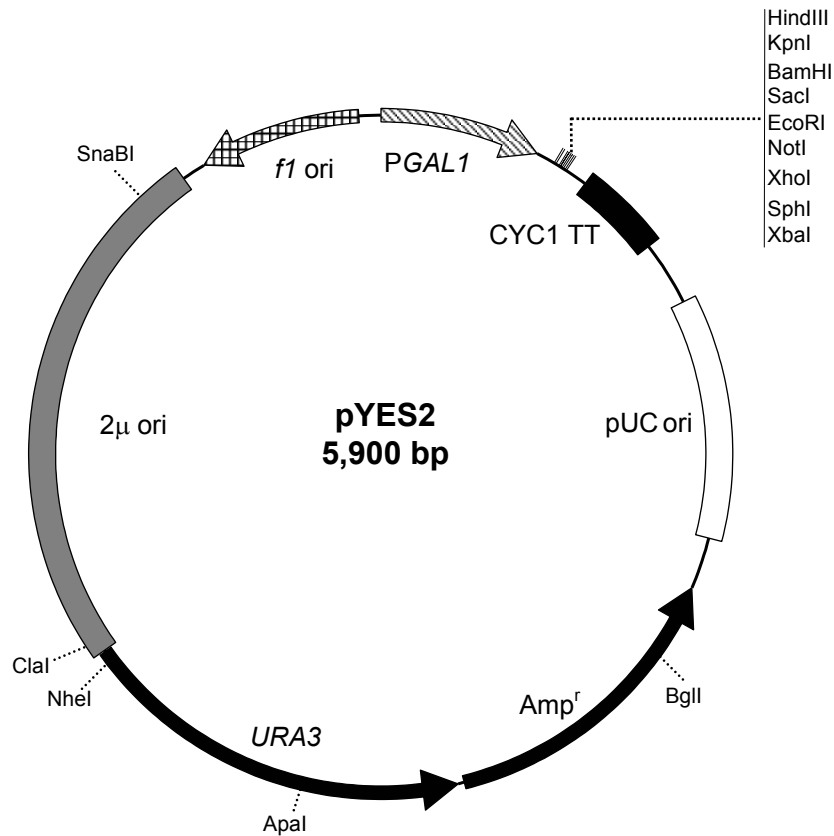

**Figure 7 Physical map of pYES2**

This plasmid contains ampicillin resistant gene ( $Amp^r$ ), origin of replication derived from pMB1 plasmid family (pMB1 ori), galactose-induced promoter (*PGAL1*), transcription termination (*CYC1 TT*), uracil gene for use as selective marker in yeast (*URA3*), f1 origin of replication (*f1 ori*), T7 promoter and  $2\mu$  origin of replication ( $2\mu$  ori). This figure was derived from pYES2 manual, Invitrogen, USA.

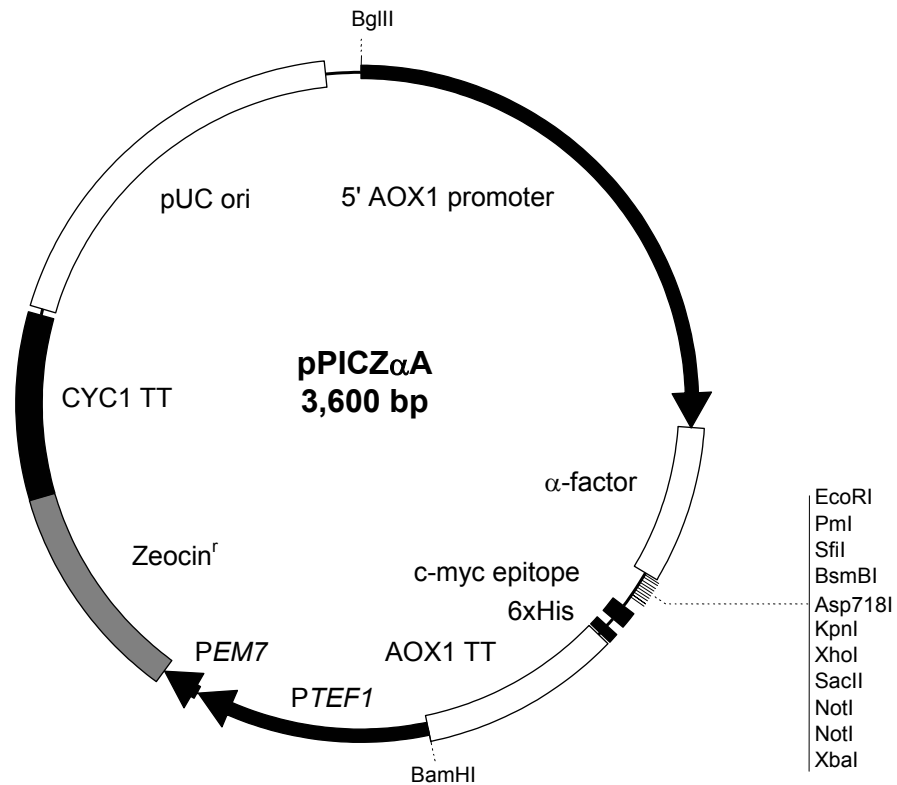

**Figure 8 Physical map of pPICZ $\alpha$ A**

This plasmid contains Zeocin<sup>TM</sup> resistant gene (Zeocin), plasmid origin of replication in *E. coli* (pUC ori), 5' *AOX1* promoter region, *AOX1* termination (*AOX1* TT). The expression of Zeocin<sup>TM</sup> resistant gene was controlled by *EM7* and *TEF1* promoter and *CYC1* terminator. The restriction enzyme recognitions in multiple cloning sites are indicated.  $\alpha$ -factor is a coding sequence to enhance the secretion of expressed protein. C-myc epitope and hexamer of histidine tag (6XHis) are included to facilitate detection and purification of the expressed protein. This figure was adapted from pPICZ $\alpha$ A, B and C manual, Invitrogen, USA.

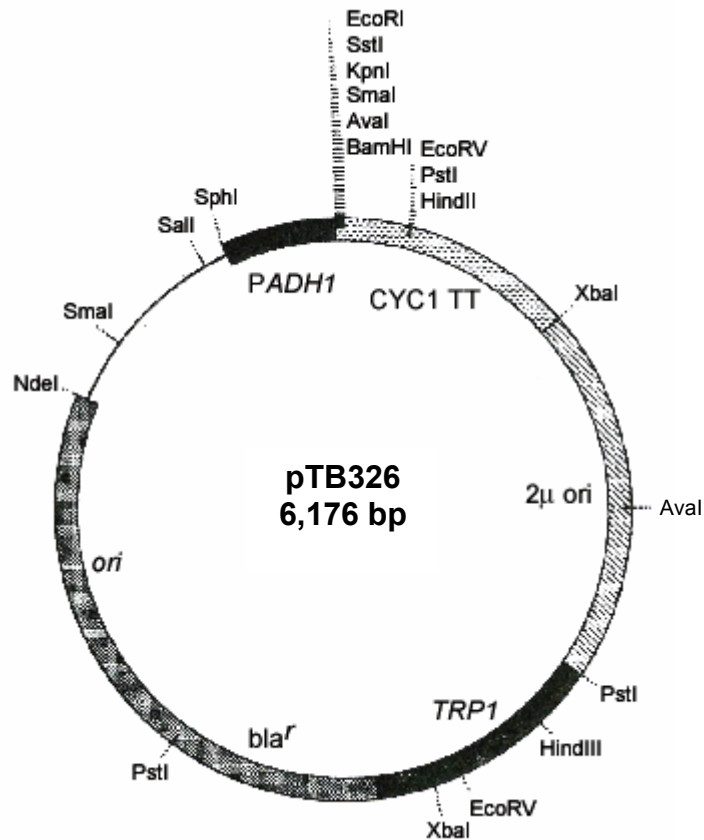

**Figure 9 Physical map of pTB326**

This plasmid contains ampicillin resistant gene (*bla<sup>r</sup>*), *E. coli* origin of replication (*ori*), yeast origin of replication ( $2\mu$  ori), tryptophan selectable marker (*TRP1*), *ADHI* promoter (*PADH1*) for constitutive expression of cloned gene and transcription terminator (*CYC1 TT*). The recognition sites of restriction enzymes are indicated. (59)

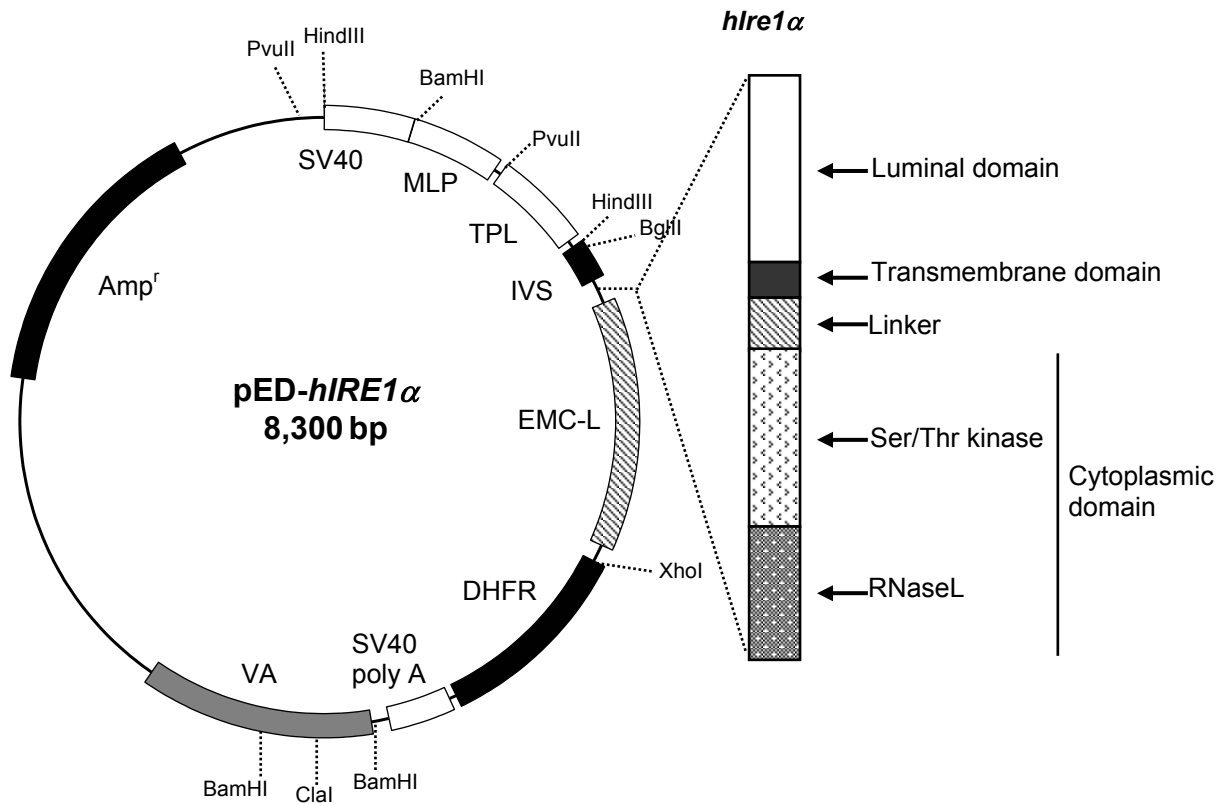

**Figure 10 Physical map of pED-hIRE1α**

This plasmid contains human *IRE1α* cDNA under control of adenovirus major late promoter (MPL) for constitutive expression in mammalian cell, COS-1. Domains organization of the encoded protein was indicated. pED vector contains origin of replication and ampicillin resistant gene from pUC. SV40 origin of replication allows plasmid propagation in COS-1 cell. This figure was adapted from Plongthongkum, N., *et al.* 2004 (48).

Pre-induction and induction medium were prepared by using 1% (w/v) D-raffinose (Sigma, USA)-2% (w/v) D-galactose (Sigma, USA) and 2% (w/v) D-raffinose instead of 2% (w/v) D-glucose, respectively. Most amino acid composition in the medium was diluted from 10X amino acid as indicated in Table 3. Whereas adenine, uracil, L-leucine, L-histidine and L-tryptophan were prepared as separate stock solution: 1.2 g/l adenine, 2.4 g/l uracil, 3.6 g/l L-leucine, 2.4 g/l L-histidine and 2.4 g/l L-tryptophan. All amino acid and sugar solutions were sterilized by filtering through 0.22  $\mu\text{m}$  filter.

#### **3.7.4 Mammalian cell culture medium**

COS-1 cell was cultured in complete Dulbecco's Modified Eagle Medium, DMEM (29). The complete DMEM was prepared by supplementing with 10% fetal bovine serum (FBS), 100 units/ml penicillin, 100  $\mu\text{g/ml}$  streptomycin and 5mM L-glutamine.

### **3.8 Primer and Oligonucleotide**

All primers used in this study, are listed in Table 4. The primers were purchased from PROLIGO Primers and Probes, Singapore, except 867G and 676G were synthesized by Biomedical Research Core Facilities, University of Michigan.

### **3.9 Computer software**

Clustal X, InforMax Inc., USA

Prism version 3.0, GraphPad Software Inc., USA

**Table 2 Synthetic defined medium used in the study**

<b>Media</b>	<b>Recipe</b>	<b>Selection for yeast obtained</b>
Uracil dropout (-URA)	0.67% (w/v) Yeast Nitrogenous Base (YNB) with amino acid 0.2% (w/v) Casamino acid 40 µg/ml Adenine 60 µg/ml L-leucine 2% (w/v) D-glucose ***	pYES series
Tryptophan dropout (-TRP)	0.67% (w/v) YNB without amino acid 1X Amino acid Solution 40 µg/ml Adenine 20 µg/ml Uracil 20 µg/ml L-histidine 60 µg/ml L-leucine 2% (w/v) D-glucose ***	pTB series
Uracil, Tryptophan dropout (-URA-TRP)	0.67% (w/v) YNB without amino acid 1X Amino acid Solution 40 µg/ml Adenine 20 µg/ml L-histidine 40 µg/ml L-tryptophan 2% (w/v) D-glucose ***	pYES series pTB series

\*All media were supplemented with 50 µg/ml myo-inositol.

\*\* For plate preparation add agar to final concentration 2% (w/v).

\*\*\* For induction media preparation 2% (w/v) D-glucose was replaced with 1% (w/v) D-raffinose-2% (w/v) D-galactose, or use 2% (w/v) D-raffinose instead for pre-induction media.

**Table 3 The 10X amino acid table (61)**

<b>Nutrient</b>	<b>Concentration (<math>\mu\text{g/ml}</math>)</b>
L-arginine	200
L-aspartic acid	1000
L-glutamic acid (monosodium salt)	1000
L-lysine (mono-HCl)	300
L-methionine	200
L-phenylalanine	500
L-serine	3750
L-threonine	200
L-tyrosine	300
L-valine	1500

**Table 4 List of oligonucleotide primers**

Nucleotide sequences of each primer (5'→3' direction), size and melting temperature (T<sub>m</sub>) of each oligonucleotide were indicated. Mutated nucleotide introduced to the primer sequences is indicated by bold letter. Restriction enzyme recognition sites are shown as underlined alphabets.

Name	Sequences (5'→3')	Size (nt)	T <sub>m</sub> (°C)
676G	GCCCAAGAGTATGCCGATTCCG	22	70
867G	ACCCTC <b>GAG</b> CGATTGTCTTCATG	23	70
HAC1 gene ( <i>Bgl</i> II) sense	CCT <b>AGATCT</b> TATAGTCACGTGACATG	25	50
HAC1 gene ( <i>Xba</i> I) antisense	GAGGT <b>CTAG</b> ACCAGCCAGTCTTGCTCC	27	63
HAC13'UTR ( <i>Kpn</i> I) antisense	CGAGGT <b>ACC</b> CTACAGAGAGCCGTGAG	26	62
3' Splicesite sense (MT)	CTTGACTGTCCGCAGCGCAGTCAG	25	64
3' Splicesite antisense (MT)	CTGACTGCGCTGCGGACAGTACAA	24	64
HAC1-3'UTR sense	CATGAAGACAATCGCTAGAGGGTATA	26	59
yActinsense ( <i>Bam</i> HI)	GCC <b>GATCC</b> GCCGGTGACGACGCTCC	26	78
yActinantisense ( <i>Eco</i> RI)	TCGT <b>CGAATC</b> TGTGTTTTGAGATC	24	58
Zeocin 5' ( <i>Xho</i> I) antisense	GAGTAGAAACATTTGAAGCTATGG	25	51

**Table 4 List of oligonucleotide primers (continued)**

Name	Sequences (5' → 3')	Size (nt)	T <sub>m</sub> (°C)
Zeocin 3' sense	CCGAGGAGCAGGACTGACACGTCC	24	65
HAC1 3' UTR (Probe) antisense	AGAAGGAACAGAGCGGCGTTAGC	23	60
HAC1 5' UTR (Probe) antisense	CTCTCGAGATACTGCAGATGTAGTC	25	51
HAC1 targeting sense	GTCAAACATAACAACCTCCTCCTCCCCACC TACGACAACAACCGCCACTTTTCCCACTCCT CTTCAGAGTAC *	73	87
HAC1 targeting antisense	GGTTGAAGTAGCACACACTAACCGGAGACA GAACAGTAGAAACCACTAAGCATGTTGG TCTCCAGCTTGC *	72	85
KAR2 sense ( <i>Bam</i> HI) primer	TTTACAGGGATCCTTCCACTCCTCC	25	60
KAR2 antisense ( <i>Xho</i> I) primer	TTCTCTTTCACCTCGAGCTAGGGCC	25	60

\* : Nucleotide sequences in box are complementary to the sequences of Zeocin<sup>TM</sup> expression cassette from pPICZαA.

## CHAPTER 4

### METHODS

#### 4.1 *in vitro* cleavage of *HAC1* RNA by hIre1 $\alpha$ p

##### 4.1.1 Site-directed mutagenesis

Site-specific mutagenesis of *HAC1* fragment was performed using QuickChange<sup>®</sup> site-directed mutagenesis method (Startagene, USA). Two complementary primers (sense and antisense) covering the 3' splice site were designed explicitly to mutate nucleotide at +1 position (A→C). The pBluescript-*HAC1b* (Figure 6) was used as a template and the PCR profile used for mutagenesis was shown in Table 5. Upon the completion of the amplification, the PCR reaction was appended with *DpnI* and then transformed into *E. coli* competent cell by heat shock procedure (5.2.1). The recombinant plasmid with desired mutation was screened and confirmed by DNA sequencing.

##### 4.1.2 *in vitro* transcription of *HAC1* RNA

pBluescript-*HAC1b* carrying wild type or mutated *HAC1* sequence was linearized with *XhoI* digestion, purified by phenol/chloroform (1:1) extraction and precipitated in ethanol. 1  $\mu$ g of linearized template was used in the *in vitro* transcription reaction containing 2.5 mM each of NTP mix (ATP, CTP and GTP), 100  $\mu$ M UTP, 1X T7 reaction buffer (Ambion), 20 units of RNase inhibitor, 2  $\mu$ l of T7 enzyme mix (Ambion) and 50  $\mu$ Ci  $\alpha$ -[<sup>32</sup>P]UTP in a total volume of 20  $\mu$ l. The reactions were incubated at 37°C for 2 hours. The transcription reaction was terminated by RNA loading dye [95% (v/v) formamide, 20 mM EDTA, 0.05% (w/v) bromphenol blue and 0.05% (w/v) xylene cyanol FF]. The <sup>32</sup>P-labeled *HAC1* RNA was analyzed in 6% urea-polyacrylamide gel electrophoresis [5.7% (w/v) acrylamide, 0.3% (w/v) N,N'-methylene-bis-acrylamide, 50% (w/v) urea in 1X TBE buffer] using slab Electrophoresis Chamber (Atto Corporation, Japan). The intact <sup>32</sup>P labeled *HAC1* RNA was visualized by autoradiography.

The gel slice containing the labeled RNA was ground into fine texture and dissolved in 400  $\mu$ l elution buffer [50 mM Tris-HCl (pH 8.0), 1 mM EDTA, 300 mM Sodium acetate (pH 5.3)], equal volume of acidic phenol:chloroform (1:1) was added and incubated at 4°C for overnight with constantly shaking. The gel debris was removed by centrifugation at 14,000 rpm for 5 minutes at room temperature. Supernatant was re-extract once with chloroform. The RNA in supernatant was precipitated with 0.1 volume of 3 M sodium acetate (pH 5.5) and 2 volumes absolute ethanol, pellet by centrifugation and washed with 70% (v/v) ethanol. The RNA pellet was re-suspended in endonuclease buffer [20 mM HEPES, 1 mM DTT, 10 mM magnesium acetate, 50 mM Potassium acetate, 2 mM ATP]. Recovered RNA was calculated by scintillation counter (Bioscan, USA).

#### **4.1.3 hIre1 $\alpha$ expression and immunoprecipitation**

African green monkey kidney cell, COS-1 cell, was cultured in complete DMEM medium (DMEM, 10% FBS, 100 units/ml penicillin, 100  $\mu$ g/ml streptomycin and 5mM L-glutamine) at 37°C with humidity, 10% carbondioxide and 95% atmospheric air. For transfection, a confluent dish of COS-1 cells was split at 1:5 in complete DMEM approximately 16-20 hours before transfection. The cells with 60-70% confluent was rinsed once with 7-10 ml serum-free DMEM then overlaid with transfection reaction [0.8  $\mu$ g of pED-*hIRE1 $\alpha$* , 0.1 mM Tris-HCl (pH 7.4) and 0.5 mg/ml DEAE-dextran in serum-free DMEM medium] and incubated at 37°C for 6-8 hours. The transfection solution was discarded and cell was washed with 1X PBS [0.14 M NaCl, 0.003 M KCl, 0.01 M Na<sub>2</sub>HPO<sub>4</sub>, 0.0018 M KH<sub>2</sub>PO<sub>4</sub>, pH 7.4]. The cells were incubated with 10% DMSO solution [137 mM NaCl, 5 mM KCl, 0.7 mM Na<sub>2</sub>HPO<sub>4</sub>, 6 mM D-glucose, 21 mM HEPES and 10 % (v/v) DMSO, pH 7.1] at room temperature for 2-3 minutes. The plate was washed again with 1X PBS then 5 ml complete DMEM containing 0.1 mM chloroquin was added and incubated at 37°C for 2.5 hours. Complete DMEM was replaced and cells were further incubated for 40-48 hours.

To harvest the recombinant protein, cells were rinsed twice with 1X PBS. The cells were lysed on ice for 5 minutes with NP-40 lysis buffer [1% (v/v) NP-40, 50 mM Tris-HCl (pH 7.5), 150 mM NaCl and 0.05% (w/v) SDS] supplemented with 1 mM PMSF, 2  $\mu$ g/ml leupeptin and 2  $\mu$ g/ml aprotinin. The lysate was transferred to

1.5 ml tube then centrifuged at 14,000 rpm at 4°C for 5 minutes. 50 µl of 50% protein G sepharose suspension (Amersham Pharmacia) was added into pre-cleared supernatant then incubated at 4°C for 1 hour with constant shaking. Protein bound to protein G sepharose was eliminated by centrifugation at 2,000 rpm for 5 minutes at 4°C. The pre-cleared supernatant was added with anti-hIre1αp antibody (at 1:500 dilution) and incubated at 4°C for 16-20 hours with shaking. The hIre1αp- antibody complex was captured with protein-G sepharose for 1 hour at 4°C. The complex was retrieved by centrifugation at 2,000 rpm for 5 minutes at 4°C. The complex was washed successively with 1xPBS containing 1%, 0.5% and 0.05% (v/v) Triton<sup>®</sup> X-100, respectively.

#### 4.1.4 Cleavage of labeled *HACI* RNA by hIre1αp

The labeled *HACI* RNA was incubated with immunoprecipitated hIre1αp or mock reaction in 100 µl of endonuclease buffer at 30°C for 30 minutes or 60 minutes, respectively. The reaction was stopped by phenol:chloroform (1:1) extraction. The RNA was precipitated in ethanol containing 20 µg of glycogen, at –20°C for 30 minutes condition. The RNA in the pellet was resuspended in RNA loading dye and analyzed in 10% urea-polyacrylamide gel electrophoresis. The cleaved *HACI* RNA was monitored by autoradiography.

## 4.2 Cloning and manipulation of *HACI* gene

The 1.9 kb *HACI* gene fragment was amplified by polymerase chain reaction (PCR) as profile shown in Table 5. The PCR product was cloned into *EcoRI* and *KpnI* of pTB326 sites to produce pTB-*HACI*. The *EcoRI* overhang of pTB326 was fill-in before ligation and *HACI* PCR product was digested with *KpnI* only.

To construct mutated *HACI* gene, pBluescript-MTHACI was used as backbone for construction (4.1.1). The 3' UTR of *HACI* gene was PCR amplified from *S. cerevisiae* AWY14 genomic DNA (Table 5). The 3' UTR fragment was cloned into pBluescript-MTHACI at *KpnI* and *XhoI* sites to generate pBluescript-*HACI*-3'UTR. The 1.2 kb of 5' UTR and part of 5' exon was sub-cloned from pGEM-*HACI*-1.6 (data not show). Then it was cloned into pBluescript-*HACI*-3'UTR

at *Bam*HI and *Hind*III site. The new recombinant plasmid was called pBluescript-MTHACI.

1.9 kb mutated *HACI* gene from pBluescript-MTHACI was cloned into *Eco*RI and *Kpn*I site of pTB326 by fill-in at *Eco*RI overhang before ligation. The mutated *HACI* fragment was prepared by digestion pBluescript-MTHACI with *Xba*I and *Kpn*I and then fill-in at *Xba*I site before ligation. The screening, plasmid extraction and restriction enzyme analysis of recombinant clones were performed as described previously. The pTB-MTHACI was obtained.

#### **4.2.1 The *E. coli* competent cell preparation and transformation by heat shock**

Single colony of *E. coli* DH5 $\alpha$  was inoculated in 250 ml SOB medium in 2 liters flask. The cell was grown at 18°C with shaking at 250 rpm condition. When the OD<sub>600</sub> reached 0.6 the flask was chilled on ice for 10 minutes, and the total cell was collected by centrifugation at 3,000 rpm for 7 minutes, 4°C. The cell pellets was washed in 80 ml ice-cold TB solution [10 mM PIPES, 55 mM MnCl<sub>2</sub>, 15 mM CaCl<sub>2</sub> and 250 mM KCl], re-pelleted again and re-suspended in 20 ml chilled TB solution, and centrifuged as before. The DMSO was included to final concentration 7% (v/v). The competent cell solution was aliquot to 1.5 ml tube and kept 6 months in -70°C refrigerator.

The transformation was followed the heat shock method. The competent cell was thawed on ice until completely melted. The DNA solution was added and then placed the transformation tube on ice for 30 minutes. The tube was heat shocked by incubating at 42°C for exact 90 seconds, and then quick cool on ice for 5 minutes. The LB broth was added to final volume of 1 ml, and then shaken further for 1 hour. The transformation reaction was spreaded on LB plate containing ampicillin for selection of clones.

**Table 5 The PCR profile and reaction composition**

The table revealed the PCR set up, which are used in this experiment. All of the reactions were set up in a 50  $\mu$ l thin-wall PCR tube. The template and primer pairs were also shown.

Reaction Name	Primers	PCR profile	Reaction
pBluescript-HAC1b site directed mutagenesis	-3' splice site sense -3' splice site antisense (0.4 $\mu$ M each)	Denaturation: 95°C 5 minutes 1-18 cycles : 95°C, 1 min. 45°C, 1 min. 68°C, 7 min. Complete at 68°C, 5 min.	- 1X <i>Pfu</i> buffer - 0.25 mM each dNTP - 200 ng pBluescript-HAC1b - 3 units of <i>Pfu</i> DNA polymerase
1.6 kb <i>HAC1</i>	- <i>HAC1</i> ( <i>Bgl</i> III) sense - <i>HAC1</i> ( <i>Xba</i> I) antisense (0.2 $\mu$ M each)	Denaturation: 94°C 5 minutes 1-30 cycles : 94°C, 1 min. 45°C, 1 min. 72°C, 2 min. Complete at 72°C, 7 min.	- 1X <i>Taq</i> buffer - 0.25 mM each dNTP - 50 ng of <i>S. cerevisiae</i> AWY14 DNA - 1 unit of <i>Taq</i> DNA polymerase
1.9 kb <i>HAC1</i>	- <i>HAC1</i> ( <i>Bgl</i> III) sense - <i>HAC1</i> 3'UTR ( <i>Kpn</i> I) antisense (0.2 $\mu$ M each)	Denaturation: 94°C 5 minutes 1-30 cycles : 94°C, 1 min. 45°C, 1 min. 72°C, 2 min. Complete at 72°C, 7 min.	- 1X <i>Taq</i> buffer - 0.25 mM each dNTP - 50 ng of <i>S. cerevisiae</i> AWY14 DNA - 1 unit of <i>Taq</i> DNA polymerase
3'UTR of <i>HAC1</i>	- <i>HAC1</i> 3'UTR sense - <i>HAC1</i> 3'UTR ( <i>Kpn</i> I) antisense (0.2 $\mu$ M each)	Denaturation: 94°C 5 minutes 1-30 cycles : 94°C, 1 min. 45°C, 1 min. 72°C, 1 min. Complete at 72°C, 7 min.	- 1X <i>Taq</i> buffer - 0.25 mM each dNTP - 50 ng of <i>S. cerevisiae</i> AWY14 DNA - 1 unit of <i>Taq</i> DNA polymerase
<i>hac1::zeocin</i> expression cassette	- <i>HAC1</i> targeting sense - <i>HAC1</i> targeting antisense (0.2 $\mu$ M each)	Denaturation: 95°C 5 minutes 1-30 cycles : 95°C, 1 min. 45°C, 1 min. 72°C, 2 min. Complete at 72°C, 7 min.	- 1X <i>Taq</i> buffer - 0.25 mM each dNTP - 50 ng of pPICZ $\alpha$ A - 1 unit of <i>Taq</i> DNA polymerase

**Table 5 The PCR profile and reaction composition (continued)**

Reaction Name	Primers	PCR profile	Reaction
5' overlap <i>HAC1-zeocin</i> fragment	- HAC1 ( <i>Bgl</i> II) sense - Zeocin 5' ( <i>Xho</i> I) antisense  (0.2 $\mu$ M each)	Denaturation: 95°C 5 minutes 1-30 cycles : 95°C, 1 min. 45°C, 1 min. 72°C, 0.5 min. Complete at 72°C, 7 min.	- 1X <i>Taq</i> buffer - 0.25 mM each dNTP - 50 ng of <i>Ahac1</i> / <i>Aire1</i> DNA - 1 unit of <i>Taq</i> DNA polymerase
3' overlap <i>HAC1-zeocin</i> fragment	- Zeocin 3' sense - HAC1 3'UTR ( <i>Kpn</i> I) antisense  (0.2 $\mu$ M each)	Denaturation: 95°C 5 minutes 1-30 cycles : 95°C, 1 min. 45°C, 1 min. 72°C, 0.5 min. Complete at 72°C, 7 min.	- 1X <i>Taq</i> buffer - 0.25 mM each dNTP - 50 ng of <i>Ahac1</i> / <i>Aire1</i> DNA - 1 unit of <i>Taq</i> DNA polymerase
5' <i>HAC1</i> Probe	- HAC1 gene ( <i>Bgl</i> II) sense - HAC1 5' UTR (Probe) antisense  (0.2 $\mu$ M each)	Denaturation: 94°C 5 minutes 1-30 cycles : 94°C, 0.5 min. 45°C, 0.5 min. 72°C, 1 min. Complete at 72°C, 7 min.	- 1X <i>Taq</i> buffer - 0.25 mM ATP, GTP and CTP - 0.017 mM DIG-11- dUTP - 0.033 mM dTTP - 50 ng of <i>S. cerevisiae</i> AWY14 DNA - 1 unit of <i>Taq</i> DNA polymerase
3' <i>HAC1</i> Probe	- HAC1 3'UTR sense - HAC1 3' UTR (Probe) antisense  (0.2 $\mu$ M each)	Denaturation: 94°C 5 minutes 1-30 cycles : 94°C, 0.5 min. 45°C, 0.5 min. 72°C, 1 min. Complete at 72°C, 7 min.	- 1X <i>Taq</i> buffer - 0.25 mM ATP, GTP and CTP - 0.017 mM DIG-11- dUTP, 0.033 mM dTTP - 50 ng <i>S. cerevisiae</i> AWY14 DNA - 1 unit of <i>Taq</i> DNA polymerase

**Table 5 The PCR profile and reaction composition (continued)**

Reaction Name	Primers	PCR profile	Reaction
550 bp <i>HAC1</i>	- 676G - 867 G  (0.2 $\mu$ M each)	Denaturation: 94°C 5 minutes 1-30 cycles : 94°C, 0.5 min. 45°C, 0.5 min. 72°C, 0.5 min. Complete at 72°C, 7 min.	- 1X <i>Taq</i> buffer - 0.25 mM each dNTP - 50 ng of <i>S. cerevisiae</i> AWY14 DNA or 2 $\mu$ l RT reaction - 1 unit of <i>Taq</i> DNA polymerase
<i>KAR2</i> gene	- <i>KAR2</i> sense - <i>KAR2</i> antisense  (0.2 $\mu$ M each)	Denaturation: 94°C 5 minutes 1-30 cycles : 94°C, 1 min. 45°C, 1 min. 72°C, 1 min. Complete at 72°C, 7 min.	- 1X <i>Taq</i> buffer - 0.25 mM each dNTP - 50 ng of <i>S. cerevisiae</i> AWY14 DNA or 2 $\mu$ l RT reaction - 1 unit of <i>Taq</i> DNA polymerase
<i>ACT1</i> gene	-yActinsense ( <i>Bam</i> HI) - yActinantisense ( <i>Eco</i> RI)  (0.2 $\mu$ M each)	Denaturation: 94°C 5 minutes 1-30 cycles : 94°C, 1 min. 45°C, 1 min. 72°C, 1 min. Complete at 72°C, 7 min.	- 1X <i>Taq</i> buffer - 0.25 mM each dNTP - 50 ng of <i>S. cerevisiae</i> AWY14 DNA or 2 $\mu$ l RT reaction - 1 unit of <i>Taq</i> DNA polymerase

#### **4.2.2 Recombinant *E. coli* clones screening**

Individual colonies of *E. coli* carrying candidate recombinant plasmid were selected and spotted onto ampicillin-containing LB agar plate and incubated at 37°C for 20 hours. The individual clones were picked to suspend in 20 µl rapid size screening buffer [5 mM EDTA, 10% (w/v) D-sucrose (Sigma, USA), 0.25% (w/v) SDS, 100 mM NaOH, 60 mM KCl and 0.05% (w/v) bromphenol blue]. The cell lysate was incubated at 37°C for 5 minutes then chilled on ice for 5 minutes. Cell debris was removed by centrifugation at 14,000 rpm for 5 minutes at 4°C. A 20 ml volume of supernatant was run on 0.8% agarose gel electrophoresis. Clones that gave a larger size of plasmids compared to the control were selected for plasmid isolation by alkaline lysis method.

#### **4.2.3 Plasmid DNA extraction by alkaline lysis method**

*E. coli* harboring candidate clones were inoculated in 3 ml ampicillin-containing LB broth and grown at 37°C for 24 hours with constant shaking. The cell was pelleted by centrifugation at 14,000 rpm for 1 minute. The pellet was re-suspended in cold 100 µl solution I [50 mM D-Glucose, 25 mM Tris-HCl pH 8.0, 10 mM EDTA pH 8.0], then vigorously vortexed. A volume of 200 µl freshly prepared solution II [0.2 N NaOH, 1% (w/v) SDS] was added and gently mix then placed on ice for 5 minutes. A volume of 150 µl solution III [3 M potassium acetate, glacial acetic acid] was added, gently mixed by vortex, and then placed on ice for 5 minutes. Cell debris was eliminated by centrifugation at 14,000 rpm for 5 minutes. The supernatant was transferred to a new tube. The RNA contamination was eliminated by adding 20 µg RNase A and then incubated at 37°C for 5 minutes. The sample was extracted with equal volume phenol/chloroform (1:1) to remove protein contaminant then precipitated with ethanol. The mixture was centrifuged at 14,000 rpm for 10 minutes. The plasmid DNA was pelleted, then washed with 70% ethanol and re-pelleted again. The pellet was dissolved in sterile deionized water.

#### **4.2.4 Purification of plasmid DNA using QIAprep spin Miniprep kit**

To prepare the high quality plasmid DNA, the QIAprep spin Miniprep kit was used. The 3 ml overnight bacterial culture was collected by centrifugation at 14,000 rpm for 1 minute. The cell pellet was resuspended in 250 µl Buffer P1 [50 mM Tris-HCl (pH 8.0), 10 mM EDTA and 100 µg/ml RNase A]. 250 µl Buffer P2 [200

mM NaOH and 1% (w/v) SDS] was added and the tube was gently inverted following by addition of 350  $\mu$ l of Buffer N3. The mixture was by inverting the tube 4-6 times before centrifugation at 14,000 rpm for 10 minutes. The supernatant was directly applied to QIAprep spin column then centrifuged at 14,000 rpm for 1 minute. The DNA bound to the column was sequentially washed with 500  $\mu$ l Buffer PB then with 750  $\mu$ l Buffer PE, respectively. The column was air dried for 1 minute. A volume of 50  $\mu$ l sterile deionized water was added to the column, plasmid DNA was eluted by centrifugation at 14,000 rpm for 1 minute.

#### **4.2.5 Restriction enzyme digestion analysis of recombinant clones**

After recombinant plasmid DNA was obtained the insert size plasmid was determined by restriction enzyme digestion. Cleaving reaction was set as contained 100 ng -1  $\mu$ g plasmid, 1X reaction buffer, 0.1 mg BSA and 1-2 units of enzyme. The digested reaction was analyzed on 1.0% agarose gel electrophoresis.

#### **4.2.6 DNA sequencing**

The nucleotide sequencing of recombinant plasmid was determined by chain termination method by automated DNA sequencing facility (Macrogen, Korea).

### **4.3 *Δhac1/Δire1* double deleting strain construction**

#### **4.3.1 PCR amplification of *hac1::zeocin* expression cassette**

The 70 bp long primers were used in the PCR reaction. The PCR cycles and composition were listed in Table 5. The PCR product was observed by running 5  $\mu$ l PCR reaction in 1.0% agarose gel electrophoresis.

#### **4.3.2 *S. cerevisiae* transformation with *hac1::zeocin* cassette**

The *hac1::zeocin* expression cassette was transformed into AWY19 by using lithium acetate method (59). A single yeast colony of 48 hours yeast culture was inoculated into 50 ml YEPD broth in 250 ml flask. The inoculated media was incubated at 30°C for 20 hours, with constant shaking at 250 rpm. The OD<sub>600</sub> of overnight culture was determined and cell concentration was adjusted to OD<sub>600</sub> of 0.4 in 50 ml YEPD medium. The incubation was prolonged for 2-3 hours. The yeast cell was collected by centrifugation at 6,000 rpm for 10 minutes at 4°C. The pellet was washed in 40 ml 1X TE [10 mM Tris-HCl (pH7.4), 1 mM EDTA] and 2 ml 1X

LiOAc/0.5X TE [100 mM lithium acetate (pH 7.5), 5 mM Tris-HCl (pH 7.5) and 0.5 mM EDTA], respectively, re-pelleted using centrifugation as previous. The yeast solution was left at room temperature for 10 minutes. 1 µg of *hac1::zeocin* cassette DNA was mixed with 100 µg denatured sheared salmon sperm DNA and 100 µl yeast cell suspension. 700 µl of 1XLiOAc/40% PEG3350/1X TE [100 mM lithium acetate (pH 7.5), 40% (w/v) Polyethyleneglycol (MW 3350), 10 mM Tris-HCl (pH 7.5) and 1.0 mM EDTA] was added to the mixture and mixed well. The transformation reaction was incubated at 37°C for 30 minutes. The 88 µl of DMSO was added to the reaction, and then mixed well. The reaction was heated shock at 42°C for 7 minutes. The pellet was collected by centrifugation at 14,000 rpm for 30 seconds and the supernatant was discarded. The pellet was washed in 1XTE and re-suspended in 100 µl 1X TE. The 100 µl transformation suspension was spreaded onto 50 µg/ml Zeocin™-containing YEPD plate. Plate was incubated at 30°C for 72-96 hours or until the Zeocin™-resistant clones were observed.

#### **4.3.3 PCR detection of overlap fragment of *hac1::zeocin* cassette of putative *Δhac1/Δire1* strain**

The two set of primers were used to detect the site-specific recombination of *hac1::zeocin* cassette to *HAC1* endogenous locus. The PCR cycles, composition and primer pair are described in Table 5. The detection of overlap region covering 5' and 3' fragment of some part *HAC1*-Zeocin™ resistant gene was performed. The template in this experiment was the genomic DNA of candidate *Δhac1/Δire1* yeast clones.

#### **4.3.4 Southern blot analysis**

The probes were created by DIG-incorporated PCR reaction. The DIG-11-dUTP was included directly with dNTP mix, with DIG-11-dUTP: dTTP ratio is 1:2. The reaction both 5' and 3' probe synthesis were set up as Table 5.

The genomic DNA was extracted from putative *Δhac1/Δire1* yeast strains. The genomic DNA was digested with *EcoRI*. To obtain complete digestion, 10 unit of *EcoRI* was added three times. The DNA pattern was observed after run digestion mixture in 0.8% agarose gel electrophoresis. The gel was soaked in 10 volumes of denaturation solution [1.5 M NaCl and 0.5 M NaOH] for 45 minutes then rinsed with

distilled water. The gel was immersed in 10 volumes of neutralization solution [1.5 M NaCl and 1 M Tris-HCl (pH 7.4)] for 30 minutes and continued soaking with new buffer for 15 minutes. The Hybond-N nitrocellulose membrane was treated by soak the gel with deionized water then with 10X SSC [1.5 M NaCl and 0.15 M sodium citrate] for 5 minutes, respectively. The DNA was transferred onto the membrane by capillary transfer using 10X SSC for 16-20 hours. Upon completion, the membrane was soaked in 6X SSC for 5 minutes. The membrane was checked for DNA attachment by visual under ultraviolet. The membrane was placed on paper towel to air dry at room temperature for 30 minutes. The membrane was put in between 2 pieces of Whatman paper and wrapped by aluminum foil, and baked at 80°C for 2 hours.

The membrane was placed in hybridization tube containing 25 ml pre-hybridization solution [50X Denhardt's reagent; 1% (w/v) Ficoll 400, 1% (w/v) polyvinylpyrrolidone and 1% (w/v) bovine serum albumin]. The pre-hybridization was performed at 42°C for 2 hours. The DIG-labeled probe was boiled for 10 minutes and quickly cooled on ice for 5 minutes before adding to pre-hybridization membrane. The hybridization reaction was performed at 42°C for 12-18 hours. The membrane was washed consecutively with 3X SSC at 42°C for 10 minutes, 0.2X SSC/0.1% (w/v) SDS at 50°C for 10 minutes and 0.1X SSC/0.1% (w/v) SDS at 50°C for 5 minutes.

The membrane was rinsed with 20 ml of washing buffer [0.1 M maleic acid, 0.15 M NaCl and 0.3% (v/v) Tween<sup>®</sup> 20, pH 7.5] for 2 minutes. The 100 ml 1X Blocking reagent [1% (w/v) blocking reagent (Boehringer Mannheim, Germany), 0.1 M maleic acid and 0.15 M NaCl, pH 7.5] was poured onto washed membrane in blocking reagent at room temperature for 30 minutes. Anti-DIG-AP conjugate Fab (dilution 1:10,000) was added in 20 ml, incubated at 25°C for 30 minutes. The membrane was washed twice in 100 ml washing buffer at room temperature for 15 minutes. The membrane was equilibrated with 20 ml detection buffer [0.1 M Tris-HCl and 0.1 M NaCl, pH 9.5] for 2 minutes. The CDP-Star was diluted to 1:50 in 2 ml Detection buffer and incubated with membrane in hybridization bag for 5 minutes. The excess solution was drained. The membrane was exposed to X-ray film at room temperature.

#### 4.4 The $\beta$ -galactosidase assay

The total induced cells were collected (the details about induction are described below.). The OD<sub>600</sub> of culture was determined and the pellets were re-suspended in 200  $\mu$ l Z buffer [60 mM Na<sub>2</sub>HPO<sub>4</sub>, 40 mM NaH<sub>2</sub>PO<sub>4</sub>, 10 mM KCl, 1 mM MgSO<sub>4</sub> and 50 mM  $\beta$ -mercaptoethanol]. The 10  $\mu$ l of cell suspension was diluted in 990  $\mu$ l of Z buffer. The diluted cell suspension was added with one drop of 0.1% SDS and two drops of chloroform, that the reaction tube was mixed by vigorously vortex for 15 seconds. The reaction tubes were equilibrated in 30°C water bath for 30 minutes. The cell solution was partitioned for protein determination at OD<sub>595</sub> by Bradford reagent (BIO-RAD). The substrate 200  $\mu$ l of 4 mg/ml ONPG was added to the tube and then mixed for 5 seconds. The reaction tubes were placed in 30°C water bath. When yellow color was developed the 0.5 ml of 1M Na<sub>2</sub>CO<sub>3</sub> was added to stop the reaction. The time developing color was measured. The solution was centrifuged at 14,000 rpm for 15 minutes. The cleared solution was determined at OD<sub>420</sub>. The enzymatic quantity was computed by using following equation adapting from *Current Protocol*, Ausubel, F., *et al.* 1998 (61).

$$U = \frac{1000 \times OD_{420}}{T \times V \times OD_{600}}$$

$$\text{Arbitrary Unit} = \frac{U}{\text{protein concentration in reaction tube (mg/ml)}}$$

T = time of yellow color development (minute)

V = volume of culture media (ml)

To assay the pYES containing clones, the yeast cells were grown in 50 ml 2% (w/v) D-glucose containing –URA medium in 250 ml flask for 48 hours, 30°C, 250 rpm. Then, cells were pre-induced in 50 ml 2% (w/v) D-raffinose –URA for 24 hours. Cell density at OD<sub>600</sub> were determined and adjusted to 0.4 in 50 ml medium. Then, cells were induced in 2% (w/v) D-galactose –URA for 6 hours.

The putative *Δhac1/Aire1* strains were grown in YEPD broth at 30°C for 48 hours, constantly shaking at 250 rpm. The OD<sub>600</sub> of the cultures were determined and adjusted to 0.4 in 50 ml medium. The β-mercaptoethanol was added to final concentration at 15 mM, and cultures were further incubated for 6 hours.

The pre-induction and induction of pTB and pYES containing clones were performed. The yeast clones that were grown on 2% (w/v) D-glucose, -URA-TRP plate for 72 hours were inoculated in 3 ml 2% D (w/v)-glucose, -URA-TRP broth media in 15 ml tube and then incubated at 30°C for 72 hours, 250 rpm. The media was replaced with 50 ml 2% (w/v) D-raffinose, -URA-TRP in 250 ml flask, and cells were further grown for 24 hours. The OD<sub>600</sub> was determined in each sample and adjusted to 0.4 in 1% (w/v) D-raffinose, 2% (w/v) D-galactose, -URA-TRP and 2% (w/v) D-raffinose, -URA-TRP. Cells were additionally grown for 6 hours, at the same shaking and temperature condition. The β-mercaptoethanol was applied to the final concentration of 15 mM, and cultures were incubated for 6 hours.

## 4.5 Reverse Transcription-Polymerase chain reaction

### 4.5.1 RNA extraction

The process for RNA extraction was performed as described in *Current Protocol*, Ausubel, F. *et al.* 1998 (61). The yeast clones were grown and expressed as described above, except the pellet was processed immediately with following step. The pellet cells were washed in 1 ml ice-cold sterile distilled water and re-pellet again. The 400 μl of TES solution [10 mM Tris-HCl (pH 7.5), 10 mM EDTA, 0.5% (w/v) SDS] was used to suspend the cells pellet. 400 μl of acidic phenol was added and mixed thoroughly. The reaction tube was incubated 65°C for 60 minutes with occasional vortexing. The tube was placed on ice for 5 minutes and centrifuged at 14,000 rpm for 5 minutes, 4°C. The aqueous phase was retrieved and chloroform extraction was performed at equal volume. The RNA was precipitated in ethanol. The RNA pellet was washed with 70% ethanol, and then air-dried. The pellets were dissolved in 50 μl sterile DEPC-treated deionized water. The quantity of RNA was detected by using ultraviolet spectrophotometer at wavelength 260 nm. To determine the RNA quality, RNA was mixed with RNA loading dye in 1.0%

MOPS/formaldehyde agarose gel electrophoresis, using 1X MOPS as running buffer [20 mM MOPS (pH 7.0), 2 mM sodium acetate and 1 mM EDTA]. The RNA electrophoresis method was performed as described in *Molecular Cloning*, Sambrook., J (60).

#### **4.5.2 First strand cDNA synthesis**

The 1 µg of RNA was mixed with 0.5 µg oligo-dT primer. The reaction was denatured at 70°C for 5 minutes and quick cooled on ice for 5 minutes. The 20 µl RT reaction was set up as followed: 3 mM MgCl<sub>2</sub>, 0.5 mM dNTP, 1 µg RNA, 0.5 µg oligo-dT primer, 1X ImProm<sup>TM</sup>-II Reaction buffer, 20 units RNase inhibitor and 1 unit ImProm<sup>TM</sup>-II reverse transcriptase. The RT reaction was annealed at 25°C for 5 minutes, extended at 42°C for 60 minutes and heated at 70°C for 15 minutes, sequentially.

#### **4.5.3 PCR detection of *HAC1*, *KAR2* and *ACT1* gene**

The 2 µl of complete RT reaction were used as a template for PCR. The PCR profile, primer pair and others composition were listed in Table 5. The PCR products were analyzed in 1.0% agarose gel electrophoresis.

### **4.6 Northern blotting**

The 15 µg of total RNA from various genotypes of yeast cell were prepared by mixing with 2.0 µl 5X formaldehyde running buffer [100 mM MOPS, 40 mM sodium acetate and 5 mM EDTA (pH 8.0)], 3.5 µl 37% formaldehyde and 10.0 µl formamide. The reaction was denatured at 65°C for 15 minutes, then immediately cooled on ice. The 2 µl RNA loading buffer with ethidium bromide was added and mixed. The reactions were loaded in 1% formaldehyde containing agarose gel electrophoresis. The gel was run until the bromphenol blue dye reaching one third of gel. The RNA was visualized under UV light.

The gel was incubated with DEPC-treated sterile water, and then soaked in 5 gel volume 0.01N NaOH/3M NaCl for 2 minutes. The gel was then soaked in 10 volumes of 20X SSC for 20 minutes. The Hybond-N+ was soaked completely in sterile DEPC-treated distilled water, and then immersed in 10X SSC. The capillary transfer was performed as described in southern blotting. The transferring process was

allowed for 12-14 hours. The membrane was rinsed in 6X SSC for 5 minutes. The membrane was then dried at room temperature for 30 minutes, and baked at 80°C for 2 hours. The membrane was soaked in pre-hybridization solution at 42°C for 1 hour. The radio-labeled probe was boiled for 10 minutes and added directly to pre-hybridization. The membrane was washed consecutively with 3X SSC at 42°C, 0.2X SSC/0.1% (w/v) SDS at 50°C and 0.1X SSC/0.1% SDS at 50°C, 10 minutes each. The membrane was exposed to X-ray film for 1-3 days. To re-probe the membrane, the probe bound to the membrane was stripped off by soaking the membrane in boiled 0.1% (w/v) SDS and allowed to cool at temperature, then rinsed briefly in 2X SSC. The membrane was ready for hybridization with another probe.

The 550 bp *HAC1*, *KAR2* and *ACT1* probes were produced by random primer RediPrime™ kit. The templates were produced by PCR shown in Table 5. The probes were purified by passing through Sephadex G-50 column.

## CHAPTER 5

### RESULTS

#### 5.1 UPR complementation in *S. cerevisiae* AWY19 by hIre1 $\alpha$ p

To investigate the catalytic properties of hIre1 $\alpha$  p in yeast UPR, pYES-*hIRE1*  $\alpha$ , pYES-*ire*-SCe and pYES2 were transformed into *ire1* null strain of *S. cerevisiae*, AWY19 in which endogenous *IRE1* was targeted disrupted (24). The transformants harboring each of this plasmid was selected on –URA medium. Expression of hIre1 $\alpha$  p was induced by D-galactose and restoration of the UPR pathway by hIre1 $\alpha$ p in this strain was monitored via  $\beta$ -galactosidase assay. To validate reliability of this system, the strain transformed with pYES-*ire*-SCe, carrying yeast *IRE1* gene, was used as positive control. From the result of Figure 11, pYES2 containing clone exhibited the basal level of  $\beta$ -galactosidase activity in both stress and non-stress condition. Yeast cells containing pYES-*ire*-SCe plasmid showed significant increase the basal level of  $\beta$ -galactosidase activity even in D-raffinose containing medium. Switching of the carbon source to D-galactose resulted in dramatic induction of the reporter gene activity (5 folds increase). Addition of  $\beta$ -mercaptoethanol in the medium to induce ER stress further enhances the reporter gene activity to 10 folds compared to its basal activity. This result indicated that expression of yeast Ire1p driven by pYES-*ire*-SCe plasmid can fully complement the UPR pathway in yeast strain devoid of endogenous locus of *IRE1*. Expression of hIre1 $\alpha$ p in *S. cerevisiae* AWY19 failed to activate the UPR reporter gene as indicated by undetectable of  $\beta$ -galactosidase activity in both absence and presence ER stresser,  $\beta$ -mercaptoethanol similar to obtained from the strain carrying an empty pYES2 plasmid. The failure of hIre1 $\alpha$ p to restore the UPR in this system implies that significant difference in catalytic properties between hIre1 $\alpha$ p and yIre1p may exist.

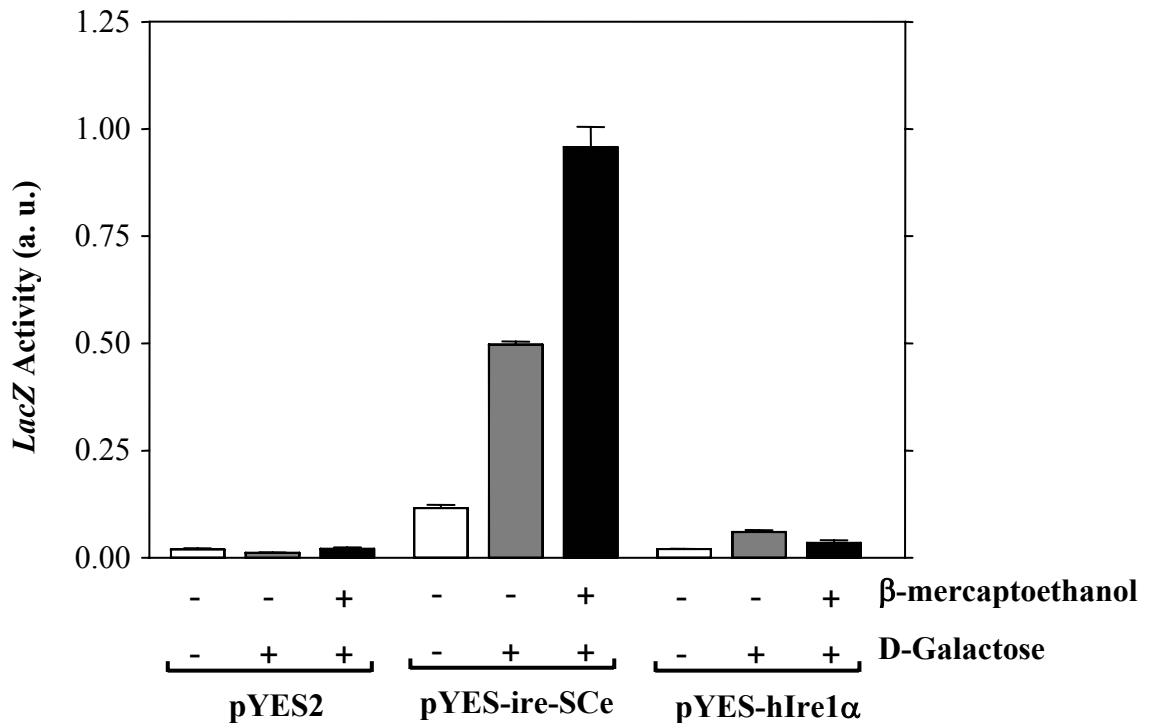

**Figure 11 Activation of UPR in *ire1* null *S. cerevisiae*, AWY19, by plasmid derived Ire1p**

Coding sequence of yeast *IRE1* gene or human *IRE1α* was cloned into pYES2 plasmid. Each plasmid was transformed into AWY19 selected on minus uracil medium. β-galactosidase assay was performed by growing yeasts cell in uracil drop out medium until OD<sub>600</sub> reached 0.4, D-galactose was then added to induce expression of Ire1p for 6 hours. β-mercaptoethanol was supplemented to the culture medium for 6 hours prior to cell harvesting. The UPR activity in each strain was monitored from β-galactosidase reporter gene. The β-galactosidase shown here represented average activity from triplicate experiments.

## 5.2 Site-directed mutagenesis of *HAC1* gene

One possibility that may contribute to the inability of hIre1 $\alpha$ p to complement the UPR function in AWY19 yeast strain is that human homologue exhibits difference specificity in RNA cleavage from that observed in yeast Ire1p. Thus this process affects the ability to initiate stress regulated *HAC1* mRNA splicing. Comparison of the nucleotide sequence at the cleavage site in the stem loop structure of 3' splice junction of *HAC1* mRNA to that presents on *XBP-1* mRNA, the endogenous substrate of hIre1 $\alpha$ p, indicated a nucleotide difference at the position +1 relative to the cleavage site. This finding leads to a hypothesis that the nucleotide at this position is crucial for cleavage specificity by hIre1 $\alpha$ p. To address this specific question, the adenosine at +1 position in the 3' stem loop cleavage site of truncated *HAC1* coding sequence in plasmid pBluescript-*HAC1b* was mutated to cytosine by site directed mutagenesis. Four candidate clones were randomly picked for analysis by automated DNA sequencing (Figure 12). The nucleotide sequence in three out of four clones carried the expected nucleotide change at +1 position of 3' splice region of *HAC1* fragment whereas the remaining of the sequence were identical among four clones which were also identical to the reported nucleotide sequences of *HAC1* gene (YFL031W) retrieved from *S. cerevisiae* genome database ([http:// www.yeastgenome. org/](http://www.yeastgenome.org/)).

## 5.3 *in vitro* cleavage of *HAC1* RNA by hIre1 $\alpha$ p

To characterize the affect of nucleotide change on RNA cleavage by hIre1 $\alpha$ p, the *in vitro* cleavage was performed. This system was successfully used to investigate the endonuclease function of Ire1p as well as hIre1 $\alpha$ p (31). The plasmid pBluescript-*HAC1b* and pBluescript-MTHAC1b were linearized and used as templates for *in vitro* transcription in the presence of  $\alpha$ -[<sup>32</sup>P] UTP. The approximate size of the *in vitro* transcribed (both wild type and mutant version) of *HAC1* RNA is approximately 550 nt consisting of 224 nt of 5' exon, 252 nt of intron and 74 nt of 3' exon corresponding to unprocessed mRNA. The transcript was gel purified and incubated with immunoprecipitated hIre1 $\alpha$ p from transient transfected COS-1 cell.

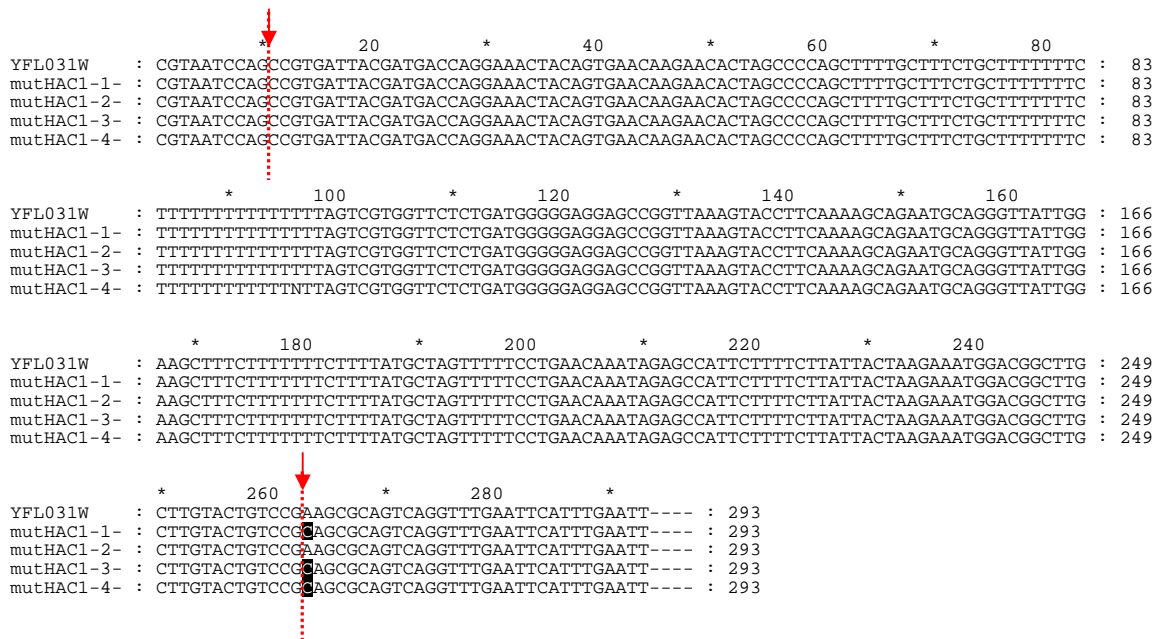

**Figure 12** The alignment of candidate mutated pBluescript-*HAC1b* clones

The sequencing results were compared the nucleotide sequences with Clustal X program. The YFL031W is a region on chromosome where *HAC1* gene located. The arrows indicate the splice site position at 5' and 3', respectively. The black box represented the position of the nucleotide that was mutated. mutHAC1-1 to 4 are individual mutagenized plasmids.

The cleavage of *HACI* RNA was monitored by denaturing gel electrophoresis. As expected, wild type *HACI* transcript was efficiently cleaved by hIre1 $\alpha$ . The cleavage could be observed within 30 min generating two fragments of approximately 224 nt and 326 nt corresponding to the size of 5' exon and intron plus 3' exon, respectively (Figure 13). Prolonged incubation did not alter the pattern of the cleavage product nor the efficiency of the cleavage. In contrast, substitution of immunoprecipitated hIre1 $\alpha$  with mock transfected sample did not result in specific cleavage of the RNA confirming that *HACI* RNA cleavage was due to the specific activity of hIre1 $\alpha$ . Taken together, these results implied that wild type *HACI* RNA can be cleaved only at the 5' spliced junction but not at the 3' spliced junction. Incubation of the mutated *HACI* RNA with hIre1 $\alpha$  also generated the fragments corresponding to the 5' exon and intron-plus 3' exon. In addition, two additional bands were observed in this reaction indicating that the mutated RNA could be cleaved by hIre1 $\alpha$  more than one site. Considering that only one nucleotide substitution was introduced onto the mutated RNA at the +1 position of the 3' spliced junction effect the splicing activity by hIre1 $\alpha$ . Moreover the size of these two extra band correspond well with the size of intron (252 nt) and 3' exon (74 nt) of *HACI* RNA (Figure 13). Thus it is most likely that the nucleotide substitution (A $\rightarrow$ C) at this specific position in the 3' stem loop structure of *HACI* RNA is crucial and sufficient to facilitate the cleavage at 3' stem loop of the mutated *HACI* RNA by hIre1 $\alpha$ . Hence this result suggested that nucleotide at position +1 relative to the cleavage site on *HACI* RNA plays an important role in determining the cleavage specificity by hIre1 $\alpha$ .

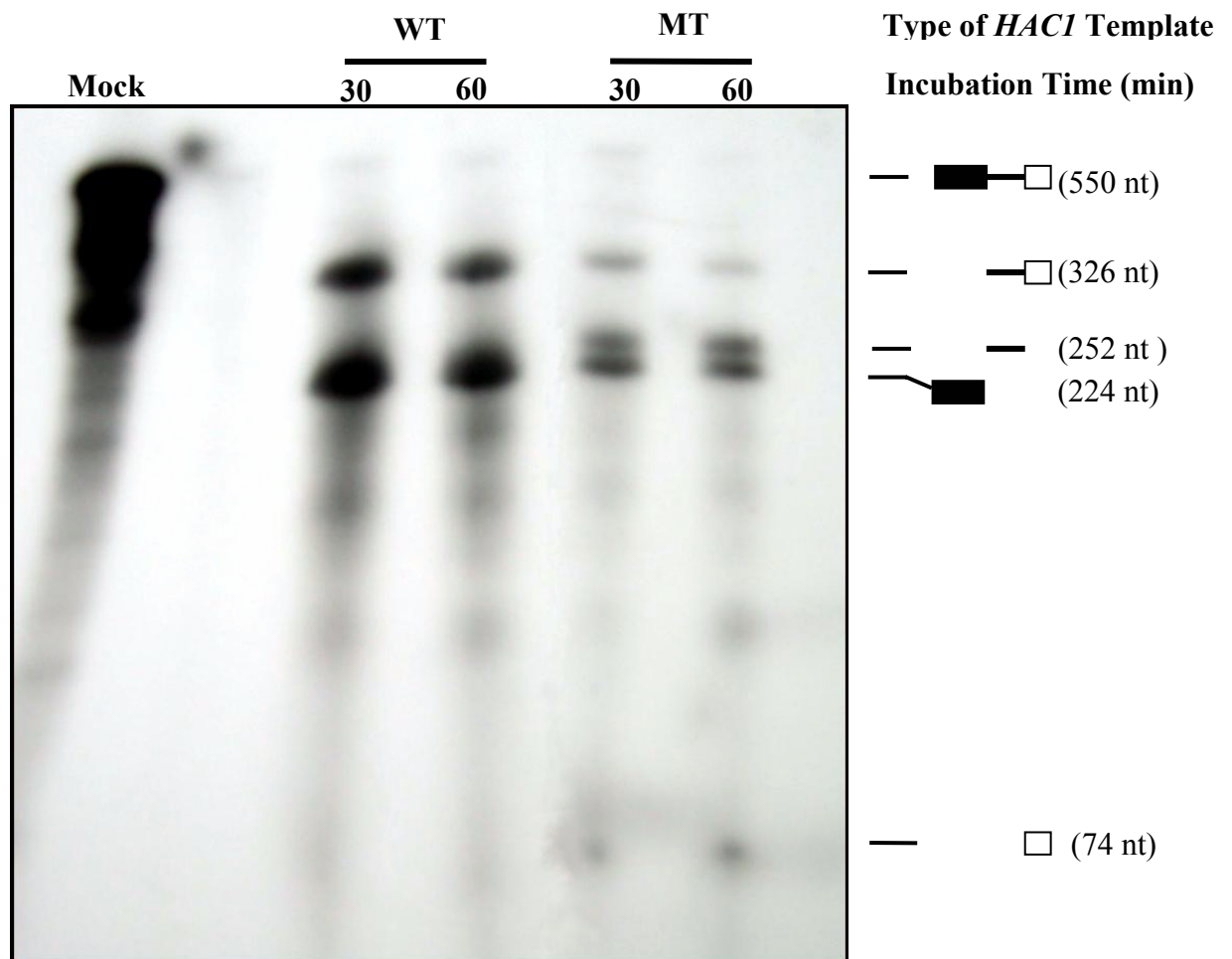

**Figure 13** *in vitro* cleavage of wild type or mutated *HAC1* fragment with hIre1 $\alpha$

The *in vitro* transcript wild type or mutated *HAC1* RNA were incubated in endonuclease reaction of hIre1 $\alpha$ . The labeled RNA was run in denaturing 10% polyacrylamide gel electrophoresis. The mock reaction revealed intact 550 nt RNA, but degradation by non-hIre1 $\alpha$  was observed. The wild type *HAC1* with hIre1 $\alpha$  generated two bands at 326 nt and 224 nt corresponding to intron-3' exon and 5' exon as indicated in right panel diagram. The labeled mutated *HAC1* transcript generated the same two bands and additional two bands at 252 nt and 74 nt which credibly equivalent to intron and 3' exon respectively. Note: wild type and mutated *HAC1* RNA were loaded with unequal amount. The bands of RNA were dictated approximately.

## 5.4 Target disruption of *HAC1* endogenous locus

To investigate whether the mutated *HAC1* gene can serve as a substrate for hIRE1 $\alpha$ p and mediate UPR activation *in vivo*, the full length gene carrying mutated residue was constructed as plasmid expression vector and transformed into yeast strain. To minimize the complication due to the activity of endogenous locus *HAC1* gene, this locus was disrupted from the genome using homologous recombination approach.

### 5.4.1 PCR amplification of *hac1::zeocin* expression cassette

In this study Zeocin<sup>TM</sup> resistant trait was selected to facilitate the screening of *HAC1* disrupting mutant. A pair of primers, *HAC1*-targeting sense and antisense primer, was designed to amplify Zeocin<sup>TM</sup> expression cassette from pPICZ $\alpha$ A. Twenty nucleotides at the 3' end of these primers were designed to facilitate the specific amplification of the resistant gene by PCR, whereas fifty nucleotides on the 5' end of both primer were designed to flank *HAC1* sequences in the genome to promote homologous recombination with the designated position of the endogenous locus. As expected, PCR amplification using these two primers and pPICZ $\alpha$ A as template yielded a specific amplification of 1.1 kb product (Figure 14).

### 5.4.2 *hac1::zeocin* expression cassette transformation

This fragment was used directly to transform *S. cerevisiae* AWY19, *Aire1* strain. The Zeocin<sup>TM</sup> resistant colonies were observed on YEPD containing Zeocin<sup>TM</sup> after 72 hours at 30°C indicating that the Zeocin<sup>TM</sup> resistant cassette was integrated into the genome and expressed. Four transformants were selected for further characterization whether this cassette caused target disruption of *HAC1* gene. If homologous recombination between the cassette and the targeted locus occurred, the structure of the targeted locus should appear as shown in Figure 15.

To search for these clones, PCR based detection was used as a screening method to identify the strain carrying an inactivated *HAC1* locus. Genomic DNA from these candidate *Δhac1/Δire1* clones was prepared and used as template for the PCR amplification. Two set of primers: *HAC1* (*Bgl*III) sense- Zeocin 5' antisense (primer A-B) and Zeocin 3' sense-*HAC1* 3'UTR (*Kpn*I) antisense (primer C-D), were designed to amplify the DNA fragment across the recombination site at 5' and 3',

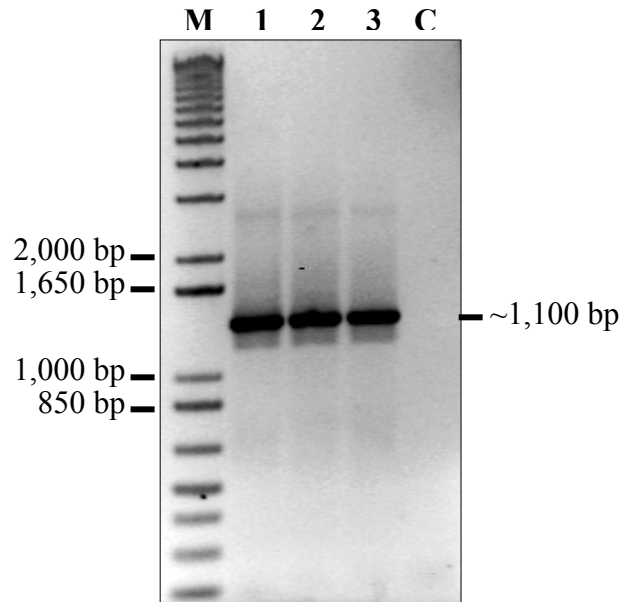

**Figure 14 PCR amplification of Zeocin™ expression cassette**

Zeocin expression cassette was PCR amplified using specific primers flanked with 50 nt derived from *HAC1* locus on both primers. The amplification was performed for 30 cycles using pPICZ $\alpha$ A as DNA template. M: 800 ng 1 kb plus marker. 1-3: individual PCR reaction with pPICZ $\alpha$ A template, 10  $\mu$ l to each lane. C: the same PCR components but lack in template.

respectively (Figure 15).

The result in Figure 16 showed that all four candidate clones (A#16, B#1, C#3 and C#4) yield positive PCR amplification with an expected size with both pair of primers. In contrast, no amplified product was observed when genomic DNA from AWY14 or AWY19 strain was used as template. Moreover, the PCR fragments were confirmed by digestion with *AvaI* and *EcoRI* for 5' and 3' overlap fragments, respectively (data not show). This result suggested that *HACI* locus in these candidate clones was mutated.

Furthermore, Southern blot analysis was used to confirm the homologous recombination of the *HACI* locus in these candidate clones. Genomic DNA was isolated from each candidate clones as well as its parental strain, AWY19, digested with *EcoRI* restriction endonuclease, run in 1% agarose gel and blotted onto membrane. The membrane was hybridized with Digoxigenin labeled DNA probes that is specifically bound the 5' or 3' end of endogenous *HACI* locus to detect 1.5 kb and 400 bp fragment, respectively (Figure 17). If homologous recombination of Zeocin™ expression cassette occurred at the *HACI* gene, this resulted in alteration of restriction enzyme recognition site in this region. The internal *EcoRI* site would be eliminated. Therefore, the *EcoRI* site was used to distinguish random integration and site-specific homologous recombination. As shown in Figure 17, hybridization of *EcoRI* digested DNA of all candidate clones with either 5' or 3' probes revealed identical hybridization signal of 2 kb in size corresponding to the expected size for *HACI* deletion. Hence, this result confirmed that all the candidate clones were  $\Delta hac1/\Delta ire1$  double deleting strain. These four clones were then used to characterize loss-of-function UPR.

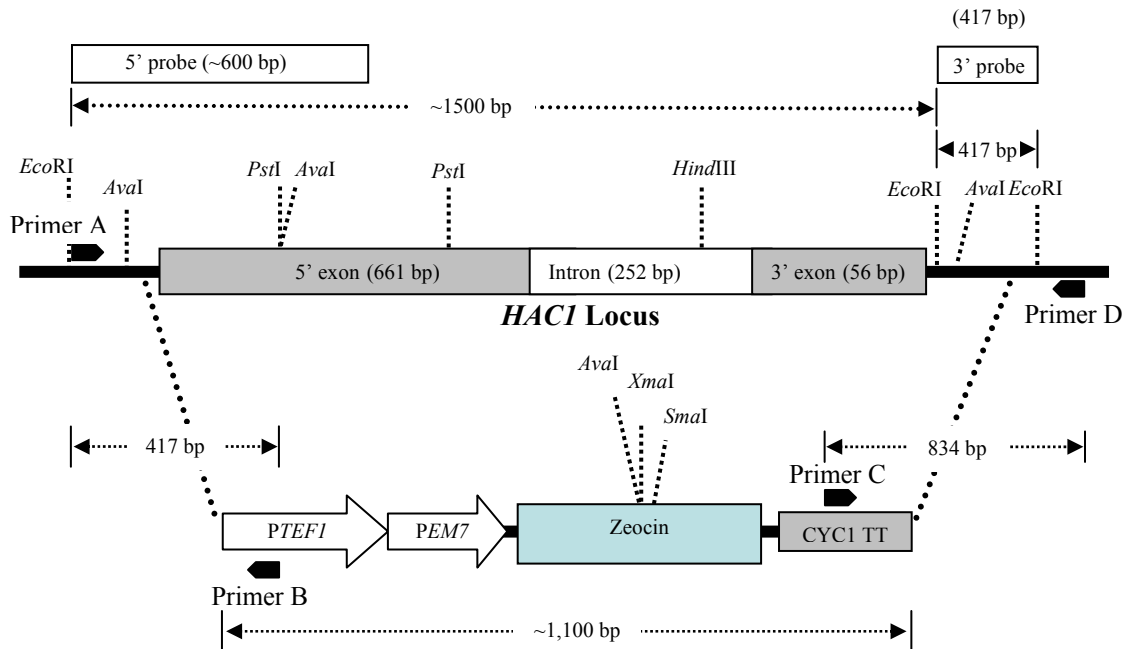

**Figure 15 Target disruption of the endogenous *HAC1* gene by Zeocin<sup>TM</sup> expression cassette**

The picture shows *HAC1* gene organization on yeast genome and specific integration region of zeocin expression cassette that is derived from pPICZ $\alpha$ A. The zeocin replacement region was designed to abolish entire *HAC1* gene. The Zeocin<sup>TM</sup> cassette was PCR amplified by using bipartite long primers containing 50 bp 5' region complementary to *HAC1* sequences. The region for 5' and 3' probe in Southern blotting were indicated. The primer position for *HAC1*-Zeocin overlap fragment amplification by PCR were shown.

- Primer A = *HAC1* (*Bgl*II) sense
- Primer B = Zeocin 5' antisense
- Primer C = Zeocin 3' sense
- Primer D = *HAC1* 3'UTR (*Kpn*I) antisense

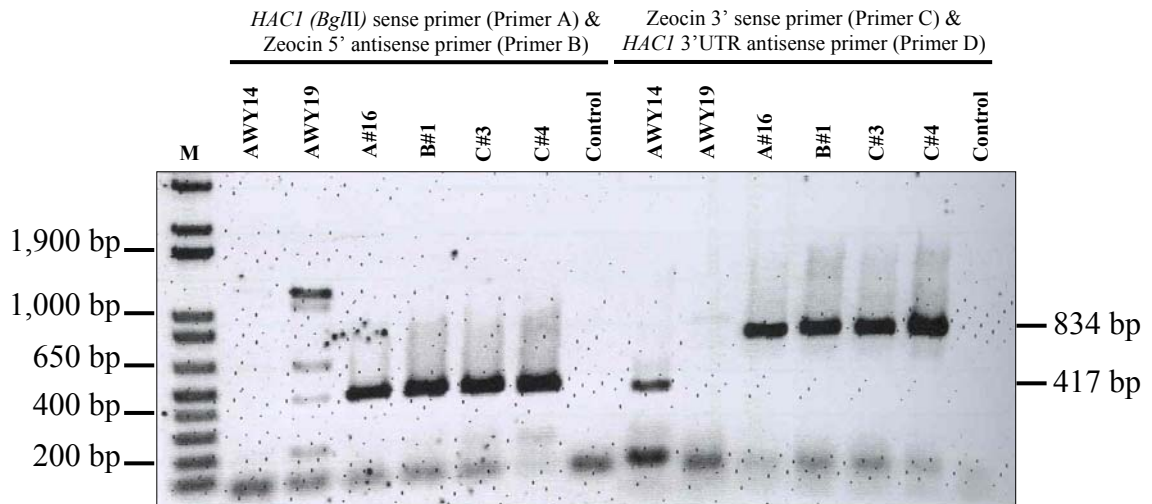

**Figure 16 Confirmation of  $\Delta hac1/\Delta ire1$  double mutations by determination the presence of overlap *HAC1-Zeocin* fragment by using PCR**

The figure represents PCR amplification of expected *HAC1-zeocin* fragment from yeast transformants. Two pairs of primers were used to identify  $\Delta ire1/\Delta hac1$  strain. Primer A and D were designed to bind with *HAC1* sequences, and primer B and C were designed to bind with zeocin cassette (Figure 15). To identify  $\Delta ire1/\Delta hac1$ , The primer pair A-B and C-D were used, expected size of A-B pair is ~400 bp and C-D is ~800 bp. As expected, both A-B and C-D primers exhibited anticipated band with candidate  $\Delta ire1/\Delta hac1$  genomic DNA template, while *S. cerevisiae* AWY14 (WT) and AWY19 ( $\Delta ire1$ ) can not. A#16, B#1, C#3 and C#4 are the zeocin resistant clones, expecting to be *S. cerevisiae*  $\Delta ire1/\Delta hac1$  strain. M is a 1kb plus marker. Control lane means PCR reaction performed without DNA template.

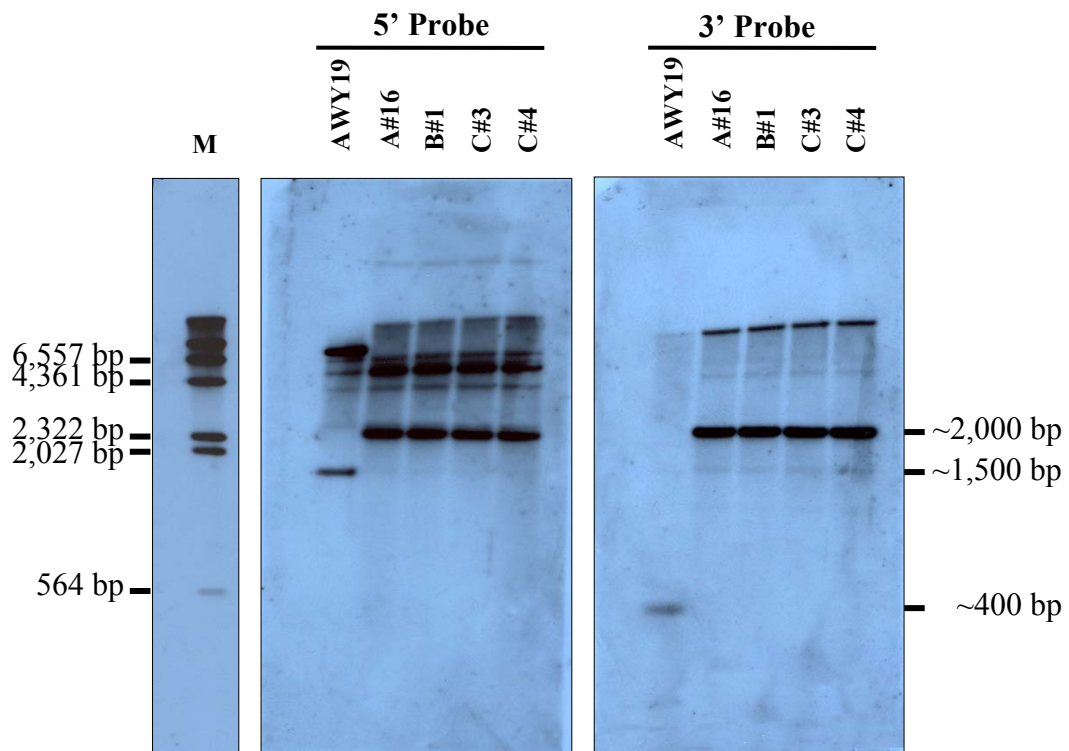

**Figure 17 Confirmation of  $\Delta hac1/\Delta ire1$  by southern blotting**

Genomic DNA from candidate  $\Delta ire1/\Delta hac1$  strains were extracted and digested with *EcoRI*, run on agarose gel electrophoresis and then transfer to membrane via southern transfer. Two probes specific to 5' and 3' region of *HAC1* endogenous locus were designed. Analytical restriction enzyme is *EcoRI*, at downstream of 3' exon, destroyed when site specific replacement with *zeocin* cassette occurs (See Figure 15). Probes were labeled with digoxigenin and detection by specific antibody to digoxigenin. A#16, B#1, C#3 and C#4 are the *zeocin* resistant clones, expecting to be *S. cerevisiae*  $\Delta ire1/\Delta hac1$  strain. M is digoxigenin labeled Lambda/*HindIII* digested fragment, 100 ng.

#### 5.4.3 UPR characterization of *Δhac1/Δire1* strain

The *Δhac1/Δire1* strains were further characterized for the loss of ability to confer UPR activation. Each individual strain was grown in YEPD media prior to expose to the medium with or without ER stressor, 15 mM β-mercaptoethanol, for 6 hours. Cell lysate was prepared and assayed for the activity of UPR reporter gene. In this assay AWY14 with intact UPR component was used as positive control. As expected all the test strains including AWY14 cultured in the absent of ER stress showed very low and comparable β-galactosidase activity (Figure 18). Addition of β-mercaptoethanol to the medium resulted in the dramatic induction of the reporter in AWY14, approximately 55 folds induction compared to the basal level. The overwhelm induction of the reporter gene in AWY 14 supports the notion that UPR activation is ER stress specific tightly regulated mechanism. In contrast, β-galactosidase in four independent *Δhac1/Δire1* strains remained at the basal level after 6 hours exposure to 15 mM β-mercaptoethanol. The result indicated that *Δhac1/Δire1* strains lost their ability to confer UPR activation.

Next, appropriate biosynthetic marker of this double deleting strain was tested. Although *Δhac1/Δire1* strain was derived from AWY19 carrying defected *leu2* genotype. However this marker was unable to accommodate the plasmid selection with *LEU2* marker. This experiment was repeated more than four times and consisting result was obtained. To search for the usable trait for plasmid selection in this strain, the phenotype for biosynthetic marker selection was performed. *Δhac1/Δire1* strains as well as its wild type strain AWY14 were spread directly into single drop out medium of -ADE, -URA, -LEU, -TRP or -HIS. Growth on these dropout medium was then monitored and evaluated as shown in Table 6. All double deleting strains were unable to form colonies on -ADE nor -URA indicating that *ADE2* and *URA3* gene can be used for selective marker in the double deleting strain. The same growth patterns were also observed in AWY14 yeast. Surprisingly medium lacking leucine or histidine fail to suppress growth of all strains. Interestingly, double deleting strain was unable to form colonies on tryptophan dropout medium while AWY14 strain grew very well in this medium.

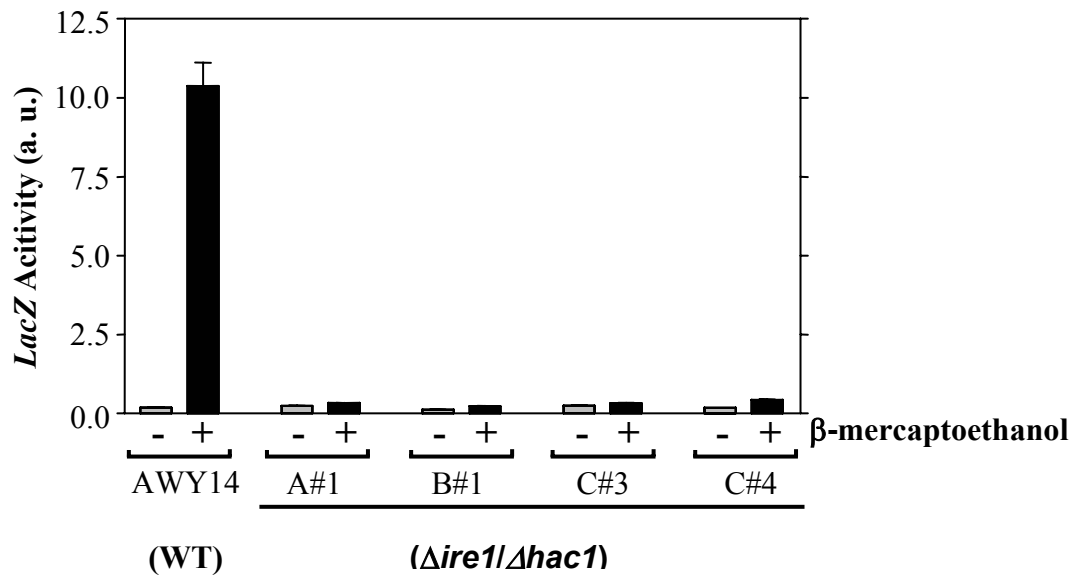

**Figure 18**  $\beta$ -galactosidase assay of expected  $\Delta ire1/\Delta hac1$  yeast strains

All yeast strains were grown in YEPD medium until  $OD_{600}$  reached 0.4, then 15 mM  $\beta$ -mercaptoethanol was applied. Cells were treated for 6 hours, then total cells were collected. All yeast strains were *S. cerevisiae*. AWY14: wild type strain. A#16, B#1, C#3 and C#4 were the Zeocin<sup>TM</sup> resistant clones, expecting *S. cerevisiae*  $\Delta ire1/\Delta hac1$  strain.

**Table 6 Media testing of  $\Delta ire1/\Delta hac1$  strain**

Both wild type and  $\Delta ire1/\Delta hac1$  yeast strains were grown in YEPD broth, overnight. The numbers of yeast cell that grown on plate were records. – and + are designated to indicate growth ability of yeast cell on plate: - = less than 10 colonies, +/- = 10-20 colonies, + = 20-100 colonies, ++ = 100-200 colonies and +++ = more than 300 colonies, respectively. \* indicates pinpoint, tiny colonies were detected.

<b>Media</b> <b>Strain</b>	<b>-ADE</b>	<b>-URA</b>	<b>-LEU</b>	<b>-TRP</b>	<b>-HIS</b>
<b>AWY14</b> <b>(WT)</b>	<b>-*</b>	<b>-</b>	<b>++</b>	<b>+++</b>	<b>+++</b>
<b>B#1</b> <b>(<math>\Delta hac1/\Delta ire1</math>)</b>	<b>-*</b>	<b>-</b>	<b>++</b>	<b>+/-</b>	<b>+++</b>

Although we was unable to explain this discrepancy, *TRP1* biosynthetic gene appears to be another good candidate marker for plasmid selection in double deleting strain, since no growth of these strains on tryptophan drop out media was observed.

## 5.5 Construction of recombinant plasmid expressing wild type and mutant *HAC1*

*HAC1* gene was PCR amplified from *S. cerevisiae* AWY14 genomic DNA by using *HAC1* (*Bgl*II) sense and *HAC1* 3'UTR (*Kpn*I) antisense primers. These primers were designed to cover the promoter region 5' UTR coding sequence and 3'UTR and polyadenylation site of the wild type gene. The PCR amplification resulted in a single amplified DNA fragment of 1.9 kb long (Figure 19). This fragment was cloned to pTB326 plasmid. Recombinant plasmids were screened by restriction endonuclease digestion using *Bgl*II-*Hind*III double digestion (data not show). The plasmid clone with correct restriction pattern was confirmed by automated DNA sequencing. This plasmid was called pTB-*HAC1* (Figure 21).

To generate full length gene carrying the designated mutation at the 3' spliced junction, the desired *HAC1* was genetic engineered using pBluescript-MTHAC1b as a starting platform. The truncated mutant *HAC1* gene was assembled to the 600 bp PCR product of 3' UTR region of *HAC1* gene to match the sequence of the wild type gene that was described earlier. This PCR amplified fragment was obtained from the reaction using *HAC1* 3'UTR sense and *HAC1* 3'UTR (*Kpn*I) antisense primer from *S. cerevisiae* AWY14 genomic DNA (Figure 20). In addition, the 1.2 kb fragment corresponding to 5'UTR and 5' exon of *HAC1* was joined to the plasmid by in frame ligation to generate pBluescript-MTHAC1. The sequences were confirmed by automated DNA sequencing. The mutated *HAC1* in pBluescript-MTHAC1 was subcloned into pTB326 to generate pTB-MTHAC1 (Figure 22).

Five independent clones of pTB-*HAC1* and pTB-MTHAC1 recombinant plasmid were characterized by digestion with *Xho*I. The two DNA bands in the digested pTB-*HAC1* reaction were 342 bp of *HAC1* gene and ~7.5 kb pTB fragment containing some part of *HAC1*, while, the pTB-MTHAC1 reaction was observed one additional band at 779 bp (Figure 23).

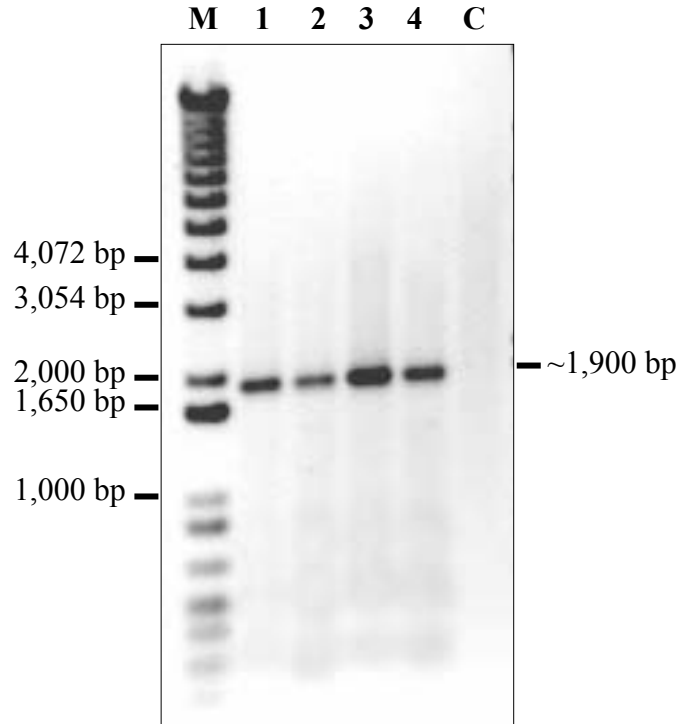

**Figure 19 PCR amplification of wild type *HAC1* gene from *S. cerevisiae***

The PCR were performed by using *S. cerevisiae* AWY14 genomic DNA as template. The primers and PCR profile are indicated in previous section. The PCR reactions were loaded to lane for 5  $\mu$ l each. M: 800 ng 1kb plus marker. 1-4: The PCR reaction using same amount AWY14 template, individual reaction. C: The PCR reaction using the same primers but no template DNA was added.

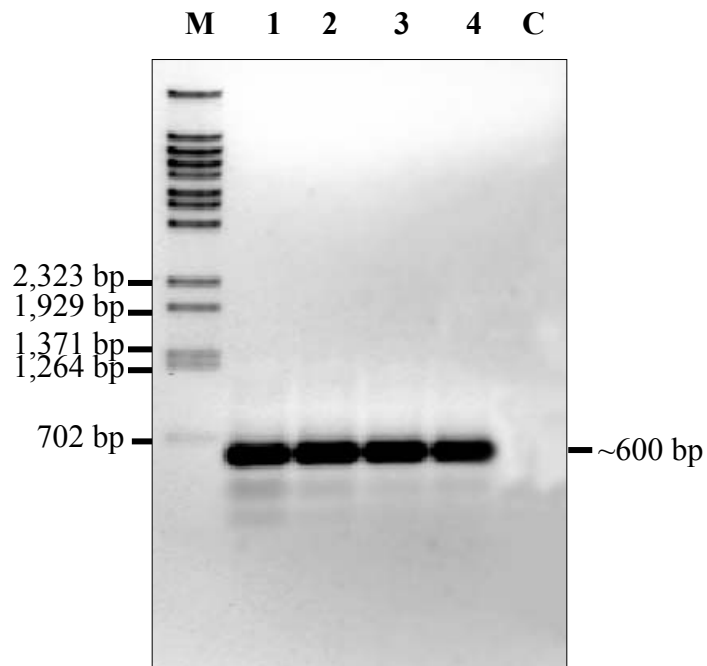

**Figure 20 3'UTR of *HAC1* amplification**

The primers specific to the 3'UTR of *HAC1* gene were used to amplify this region from *S. cerevisiae* AWY14 genomic DNA. The same expected bands (~600 bp) were obtained from four individual reactions. M: 200 ng Lambda/*BstEII* marker. 1-4: PCR reaction with AWY14 genomic DNA template. C: the similar reaction but without DNA template.

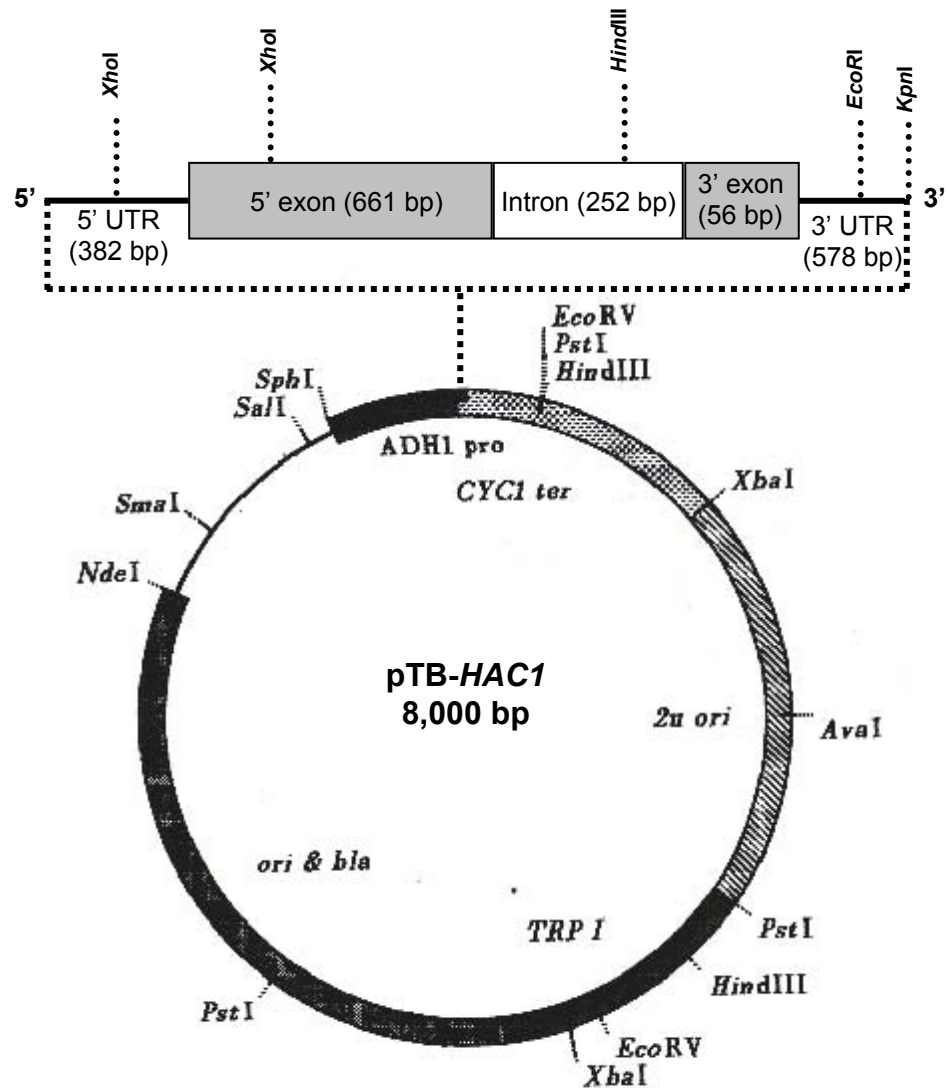

**Figure 21 Physical map of pTB-HAC1**

The 1.9 kb *HAC1* gene was cloned into multiple cloning site of pTB326. The regions of *HAC1* gene were indicated. This plasmid contains ampicillin resistant gene (*bla<sup>r</sup>*), *E. coli* origin of replication (*ori*), yeast origin of replication (2μ *ori*), tryptophan selectable marker (*TRP1*), *ADH1* promoter (*ADH1 pro*) for constitutive expression of cloned gene and transcription terminator (*CYC1 TT*). The cloning site region is controlled by *ADH1* promoter and *CYC1* terminator. The recognition sites of restriction enzymes are indicated.

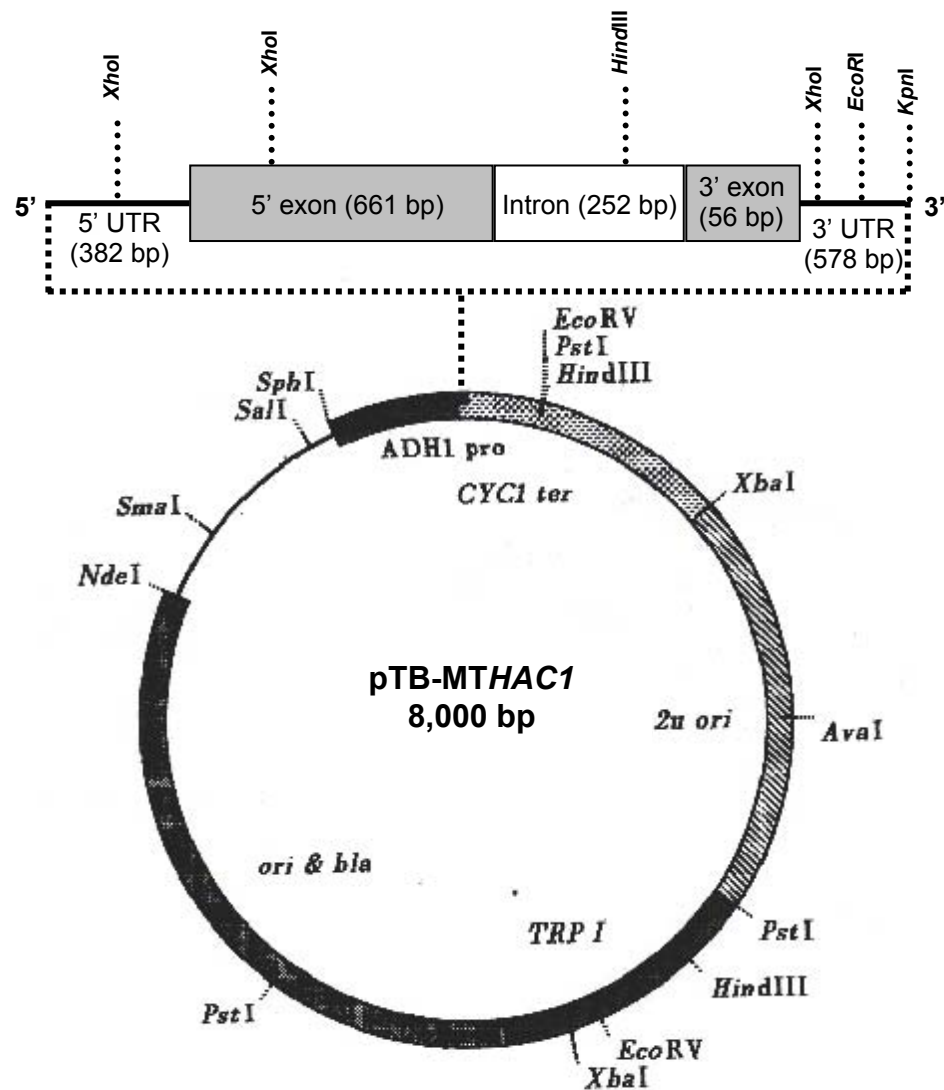

**Figure 22 Physical map of pTB-MTHAC1**

The 1.9 kb *HAC1* gene was cloned into multiple cloning site of pTB326. The regions of *HAC1* gene were indicated. The additional *XhoI* site is indicated referring to mutated *HAC1* fragment. This plasmid contains ampicillin resistant gene (*bla<sup>r</sup>*), *E. coli* origin of replication (*ori*), yeast origin of replication (2μ *ori*), tryptophan selectable marker (*TRP I*), *ADHI* promoter (*ADHI pro*) for constitutive expression of cloned gene and transcription terminator (*CYC1 TT*). The cloning site region is controlled by *ADHI* promoter and *CYC1* terminator. The recognition sites of restriction enzymes are indicated.

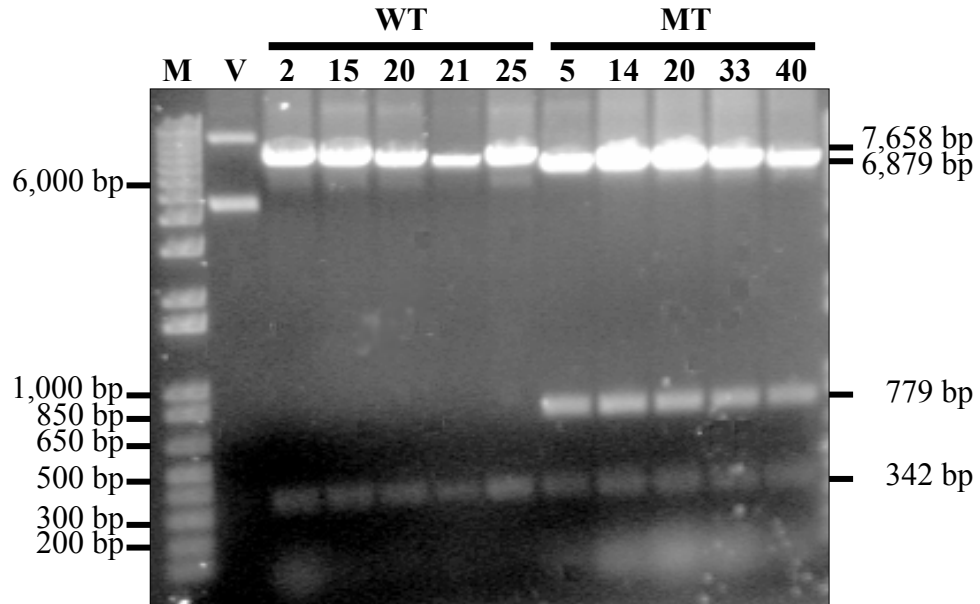

**Figure 23 The 1.9 kb *HAC1* gene in pTB plasmid characterization**

The pTB-*HAC1* and pTB-MTHAC1 plasmid were digested with *XhoI*. The wild type or mutated clones of pTB were extracted for plasmid and then digested with *XhoI*. The digested pattern of pTB-MTHAC1 with *XhoI* creates one additional band at 779 bp indicating the mutated *HAC1* gene as this site was introduced into the primer used for 3' UTR amplification. The numbers represent clone numbers.

## 5.6 RT-PCR detection of mutated *HAC1* splicing

The cooperative functions of wild type or mutant *HAC1* with *hIre1 $\alpha$*  were elucidated by transforming the corresponding recombinant plasmids into *S. cerevisiae*  $\Delta$ *hac1*/*Δire1* (B#1) as shown in Figure 24. The yeasts harboring both plasmids were selected by -URA, -TRP dropout medium. To ensure that target genes on the plasmids introduce to these cells can be expressed, all strains were cultured in D-galactose containing media as indicated in Table 2. Total RNA from indicated strains were extracted and then used as a template for first strand synthesis by oligo-dT primer in reverse transcription reaction. The cDNA were subjected to PCR amplification using 5 sets of primers specific to *HAC1*, *IRE1*, *hIRE1 $\alpha$* , *KAR2* and *ACT1*, respectively. While, the first 3 pairs of primer were used to monitor the expression of the target gene, *KAR2* primers were included in this analysis to reflect the status of stress regulated gene whereas *ACT1* specific primers were used as an internal control. The level of *ACT1* product in each sample was comparable indicating that equal amount of RNA were used in this analysis (Figure 24).

The level of *IRE1* and *hIRE1 $\alpha$*  transcript was comparable in each strain regardless of the presence or absence of another recombinant plasmid in the same cells. Moreover, the transcriptional level of these genes was independent to ER stress. Comparison of *HAC1* mRNA level by RT-PCR indicated that wild type and mutant *HAC1* can be expressed at similar level. (Figure 24, lanes 11 and 13). Interestingly, co-expression of either wild type or mutant *HAC1* with yeast *Ire1p* led to the presence of smaller *HAC1* product identical to the spliced *HAC1* indicating that constitutive *HAC1* mRNA splicing occurred in this condition (Figure 24, lanes 7-10). These results suggest that point mutation introduced to the 3' spliced site does not affect integrity of this RNA, and also the splicing reaction. In contrast, co-expression of either wild type or mutant *HAC1* with *hIRE1 $\alpha$*  did not cause constitutive *HAC1* splicing. In deed very low level of the splice mutant *HAC1* RNA was observed only when these cells were challenged with ER stress (Figure 24, lane 14). Similar result was observed from triplicate experiments with three individual clones.

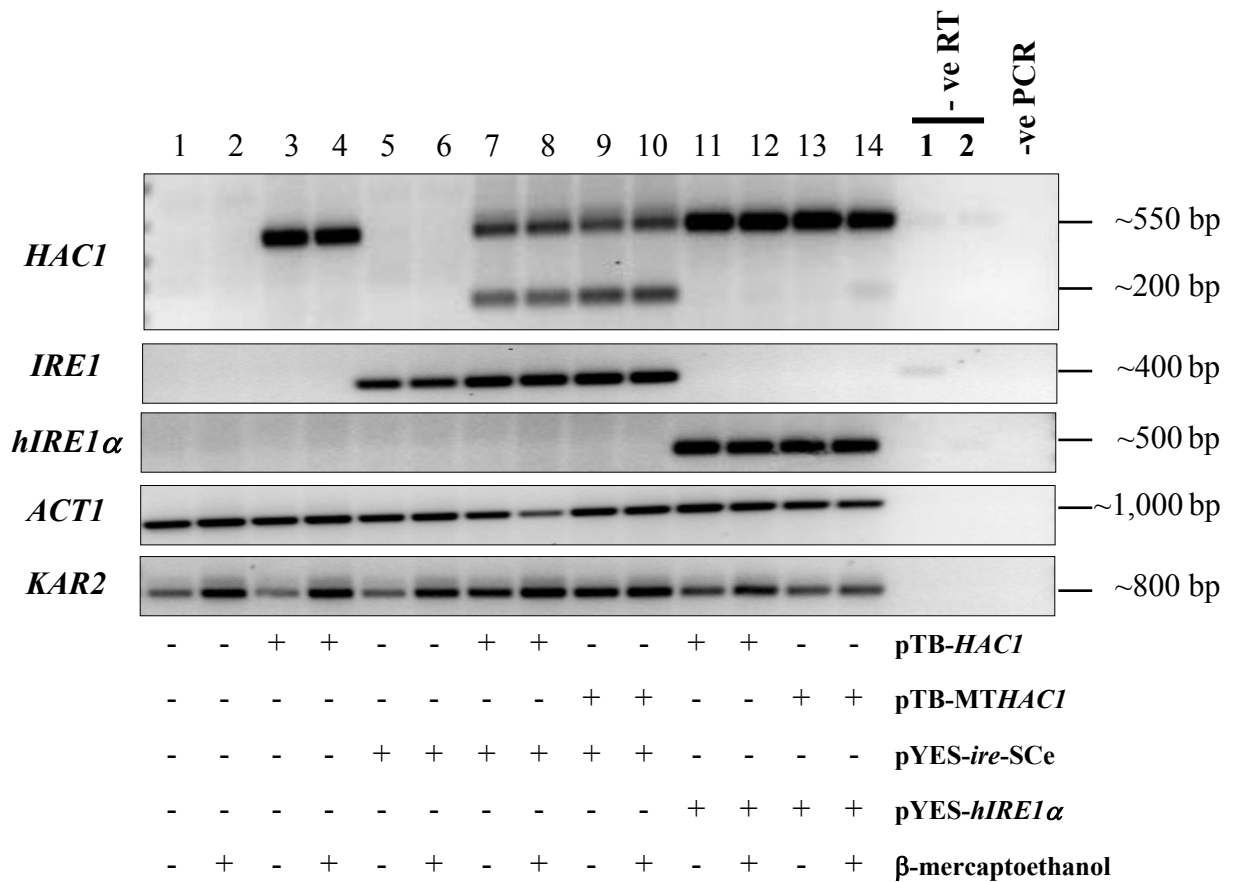

**Figure 24 RT-PCR detection of *HAC1* RNA splicing**

Total RNA from yeast clones was extracted. The combination of plasmids are indicated. The total RNA was used as a template for RT-PCR reactions. The PCR reactions were run on 1.0% agarose gel electrophoresis. The plasmids that included in given clones were indicated. -ve RT 1 and 2 are the RT reaction without reverse transcriptase of lanes 8 and 14. -ve PCR is the PCR reaction without *Taq* DNA polymerase.

## 5.7 The northern blot analysis for *HAC1* splicing detection

The total RNA of the yeast clones were extracted, blotted onto the nylon membrane and hybridized with radio-labeled DNA probes specific to *HAC1*, *KAR2* and *ACT1* mRNA. The result indicates that unspliced *HAC1* mRNA was dominantly detected in wild type or mutant *HAC1* with yeast Ire1p as well as wild type or mutated *HAC1* with hIre1 $\alpha$ p (Figure 25, lanes 7-14). The same size *HAC1* bands were also observed in control *HAC1*-expressed clone (Figure 25, lanes 3-4). The intensities of the *HAC1* band were similar in the control *HAC1*-expressed clone and wild type or mutated *HAC1* with hIre1 $\alpha$ p clones, and the wild type and mutated *HAC1* with yeast Ire1p created the less faint band of *HAC1* mRNA. Moreover, the smears downward were obviously detected on these lanes. The very faint bands corresponding with spliced *HAC1* mRNA were also observed in wild type or mutated *HAC1* with yeast Ire1p (Figure 25, lanes 7-10). However, due to the high smeary pattern in reaction of the wild type or mutated *HAC1* with hIre1 $\alpha$ p the spliced *HAC1* band in these reactions can not discerned (Figure 25, lanes 13-14). The detection of *HAC1* mRNA by radio-labeled probe was somewhat specific because the empty vector clones and yeast Ire1p-expressed clone did not observe the *HAC1* band. The detection of *KAR2* probe can not be detected because of low sensitivity (data not shown). The mRNA of yeast actin gene, *ACT1*, was detected as the equal amount of *ACT1* mRNA was detected in all lanes (Figure 25, lanes 1-14) and the size of *ACT1* mRNA is about 1,250 bp (62). The sensitivity by this method is not suitable for detection of spliced *HAC1* mRNA in mutated *HAC1* with hIre1 $\alpha$ p yeast clone.

## 5.8 UPR induction in $\Delta hac1/\Delta ire1$ strain with mutated *HAC1* and hIre1 $\alpha$ p

Restoration of UPR signaling in  $\Delta hac1/\Delta ire1$  strains was determined by  $\beta$ -galactosidase assay. As described earlier this double deleting strain lacking two crucial components of UPR signaling was unable mediate activation the reporter gene during ER stress. Interestingly, the presence of multicopy plasmid encoding only one UPR component (pTB-*HAC1* or pYES-*ire*-SCe, Figure 26, lanes 3-4 and 5-6, respectively) resulted in increase of the basal level of UPR reporter gene activity when compared to

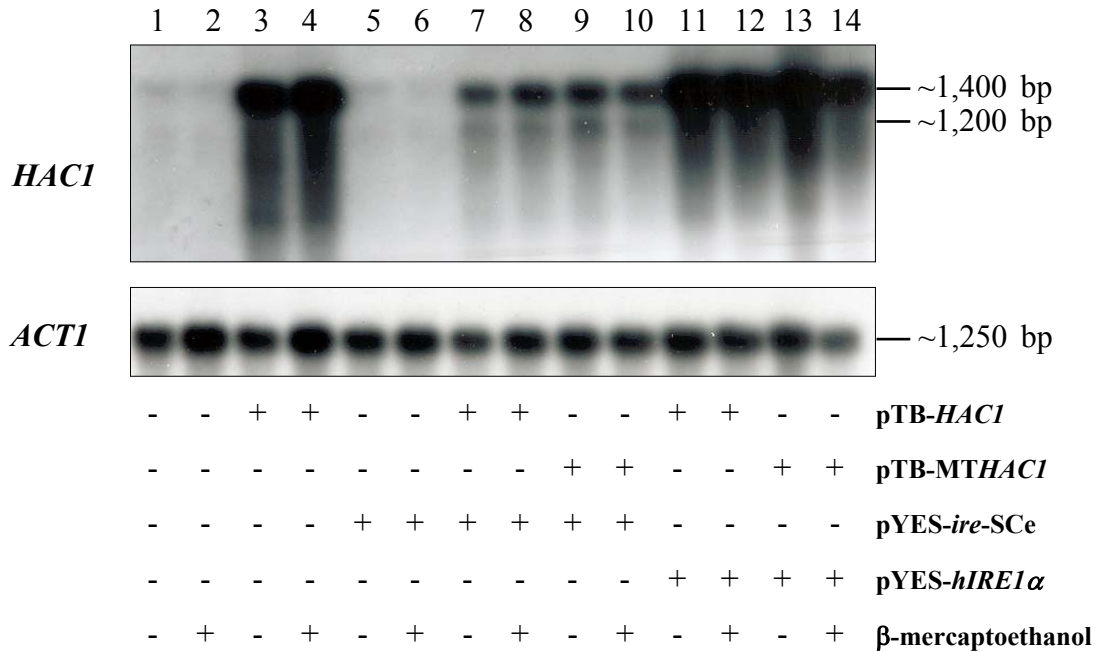
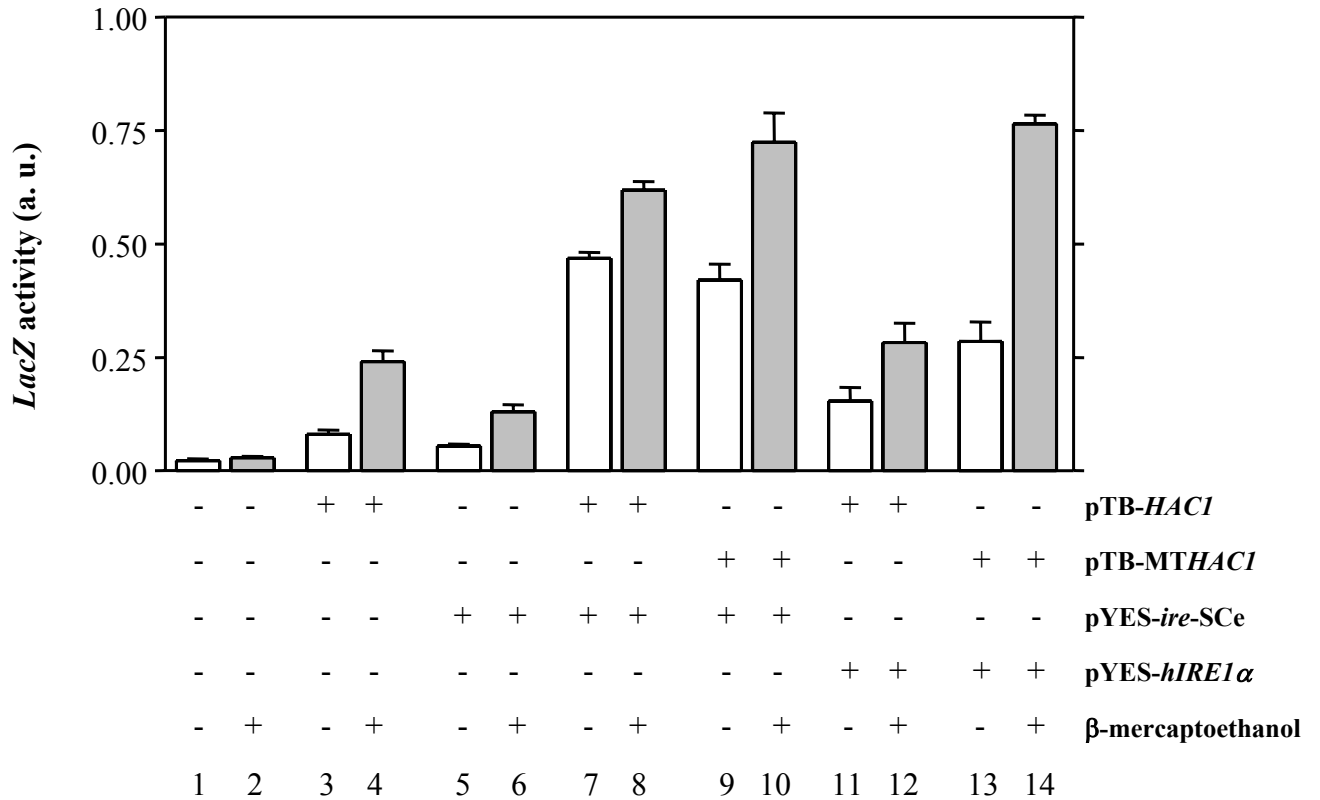

**Figure 25 Northern blotting for *HAC1* mRNA detection of mutated *HAC1***

The northern blot analysis from same RNA sample as Figure 24. The 15  $\mu$ g of RNA were resolved in 1% formaldehyde agarose gel and blotted on membrane. The detection of *HAC1* and *ACT1* mRNA were achieved by radio-labeled specific probes.

the pTB326 containing clone (Figure 26, lanes 1-2). The induction was further increased with stress induction. The overexpression of *HAC1* in  $\Delta hac1/\Delta ire1$  deleting strain on double dropout media generated further induction for 3 folds in non-stress condition while under stress condition nearly 10 folds induction was observed. In addition, the overexpression of *IRE1* generated 2 folds in non-stress condition and 5 folds in stress condition over basal level. The UPR induction via  $\beta$ -galactosidase activity increment also observed in clones obtained wild type or mutated *HAC1* with yeast Ire1p expression plasmid (Figure 26, lanes 7-10). Under expression condition, the presence of D-galactose, the activation of UPR in these two clones were detected (Figure 26, lanes 7 and 9) consistent with previous experiment. The inductions in both clones were comparable (20 folds over basal level). The UPR activity in these clones is sensitive to ER stress inducer. Twenty-five folds induction compared to was observed upon addition of ER stressor (Figure 26, lanes 8 and 10). The same level of induction indicates the activity of Hac1p in both clones which is the same and it is suggested that the mutated residue does not affect the protein activity.

However, in the wild type *HAC1* with hIre1 $\alpha$ p expressed clone showed an induction level in the same extent as *HAC1*-expressed clone, over basal level for 5 folds in non-stress and 11 folds in stress condition (Figure 26, lanes 3, 4, 11 and 12). The mutated *HAC1* with hIre1 $\alpha$ p clone (Figure 26, lane 14) under ER stress condition exhibited the induction level in the same as wild type or mutated *HAC1* with yeast Ire1p, 30 folds induction over basal level (Figure 26, lanes 8 and 10). Furthermore, the mutated *HAC1* with hIre1 $\alpha$ p clone showed a tightly regulate UPR activation as under non-stress condition the induction level of this clone was induced with the lesser extent, 10 folds over the basal level (Figure 26, lane 13 compare with lanes 1-2). This data suggested that the UPR complementation in mutated *HAC1* with hIre1 $\alpha$ p clone was restored and the activation was occurred in response to ER stress. The experiment was repeated for three times in three individual clones, in a set of experiment each sample was performed in triplicate.



**Figure 26  $\beta$ -galactosidase assay of mutated *HAC1***

The double deleting yeast strain that obtained the given pair of plasmids was grown in induction medium and assay for  $\beta$ -galactosidase. The ER stresser,  $\beta$ -mercaptoethanol, was added to induce unfolded protein accumulation. The combination pairs of plasmids were indicated. The activity unit of enzyme is reported as arbitrary unit (a. u.). The yeast strain in this experiment is *S. cerevisiae*  $\Delta hac1/\Delta ire1$  (B#1). All yeast clones were induced in 2% (w/v) D-galactose.

## CHAPTER 6

### DISCUSSION

This experiment elucidated the factor that contributes to different specificity of Ire1p from two species which yeast and its equivalent from human cells. Although both of which mediate mRNA splicing for stress alleviation in ER lumen owing to accumulation of unfolded protein, their molecular aspect appear to be different. The hypothesis of this study was based on the controversial observations from several studies regarding the ability of mammalian Ire1p to initiate stress specific splicing reaction of exogenous *HAC1* RNA (29, 49, 56, 57). Niwa *et al.* (57) demonstrated that *HAC1* mRNA expressing in mammalian cells could be correctly spliced by endogenous mammalian Ire1p upon UPR induction, although they were unable to demonstrate the synthesis of Hac1p protein in that study. In addition, the same group also shown an *in vitro* transcribed *HAC1* RNA splicing suggested that the RNA was cleaved efficiently at two 5' and 3' spliced junctions by recombinant human Ire1p overexpressed from baculovirus using *in vitro* cleavage assay. Interestingly, using the similar *in vitro* cleavage assay except that the recombinant Ire1p overexpressed in mammalian cells clearly demonstrated that hIre1 $\alpha$ p effectively catalyze the cleavage only at the 5' but not at 3' spliced of *HAC1* RNA (29). hIre1 $\alpha$ p expressed by this system has been shown to exhibit fully active catalytic activity in mediating its endogenous substrate, *XBP-1*, *in vitro* and *in vivo* implying that this discrepancy was not due to the aberrant characteristic of the recombinant protein derived from mammalian system (29). Similar finding was observed by Bowring and Llewellyn (2001) who demonstrated that *HAC1* mRNA can not be spliced in mammalian cells (56). Although *HAC1* and *XBP-1* share several conserved feature which are shown to be critical for UPR regulated splicing, the failure of the yeast RNA to be correctly

processed in mammalian host cells under ER stress condition suggested that there is certain characteristic in UPR mediated splicing reaction diverged in the two species. In this study, nucleotide at position +1 in the stem loop structure of *HAC1* RNA was identified as a critical factor for this RNA to be spliced by human Ire1 $\alpha$  endonuclease. The following aspects supported the crucial role of this nucleotide. First, substitution of adenine with cytosine at the +1 position of 3' spliced site of *HAC1* turns this stem loop to be susceptible to hIre1 $\alpha$  endonuclease as determined by an *in vitro* cleavage. It is noteworthy that *HAC1* with single mutation in this loop is closely resembled to the 3' spliced site in human *XBP-1* mRNA that was cleaved efficiently by hIre1 $\alpha$  both *in vitro* and *in vivo* (45). While the cleavage of wild type *HAC1* by hIre1 $\alpha$  created two bands of RNA representing 5' exon and intron-3' exon (29), cleavage of the mutated *HAC1* RNA generated the RNA band corresponding to the intron and 3' exon of *HAC1* RNA substrate. Although the mutant RNA was not completely cleaved by hIre1 $\alpha$  as intermediate product predicted to be intron with 3' exon still remain, dramatic improvement was observed. One possible explanation for this result is that the mutant RNA remains non-optimal for the cleavage. It is possible that there might be an additional but unidentified factor(s) involving in determining substrate specificity for hIre1 $\alpha$  that does not exist in our mutated *HAC1* RNA. Although hIre1 $\alpha$  and yeast Ire1 $\beta$  share highly conserve domain structure particularly in the kinase and endonuclease domain, the two proteins still have extensive diverged amino acid sequence in these two domains (18). Such divergent might result in different preference for its substrate. In spite of this finding, it suggests that the nucleotide in +1 position of yeast seven nucleotide loop splice region of *HAC1* dictates, at least to certain extent, the ability of hIre1 $\alpha$  to cleave *HAC1* RNA *in vitro* which is agree with the previous observations that yeast *HAC1* mRNA does not processed in mammalian cell (29; 49, 56).

Second, the mutated *HAC1* has no effect on the property of its gene product. The RNA is processed normally *in vivo* by yeast Ire1 $\beta$  under ER stress as detected by RT-PCR. The splicing reactions of wild type and mutant *HAC1* are readily detected in non stress as well as ER stress condition suggesting that the splicing occurs in comparable efficiency for wild type *HAC1* RNA and mutant *HAC1* mRNA (Figure

24). Comparison between the ratio of spliced and non spliced *HAC1* mRNA of strain harboring recombinant plasmid indicated a significant lower fraction of the spliced RNA. This could be due to high expression level of *HAC1* mRNA in this cell by constitutive strong *PADHI* promoter of pTB plasmid in which the gene was constructed. Therefore the level of overexpressed *HAC1* mRNA may overwhelm the UPR specific splicing machinery in these cells.

Albeit the mutation generated in this study resulted in amino acid change (relative to its translation initiation site) from glutamic acid to alanine, the affect of this mutant protein on the ability to mediate UPR was determined. This UPR restoration was based on  $\beta$ -galactosidase used as reporter gene constructed under the control of UPRE, the promoter from UPR-induced gene (24). For accurate low background of the assay, *hac1* and *ire1* double deleting strain was generated from *S. cerevisiae* AWY19 which was an *ire1* null strain for this specific purpose. The double deleting strain was unable to activate the reporter gene upon ER stress corresponding to the absence of neither *IRE1* nor *HAC1* transcript in the cells. The strain harboring either *IRE1* or *HAC1* expression plasmid failed to rescue its UPR activity confirming that the strain devoid of both *IRE1* and *HAC1* thus both gene products were essential for its UPR (10, 29, 32). However, the UPR activity was detected when overexpressing yeast Ire1p together with either wild type or mutant *HAC1* plasmid. Even though, the initial expected result is restricted to ER stress, UPR activation was also observed in the absence of ER stressor upon induction of Ire1p expression by D-galactose but not in glucose medium. However, similar result was observed in previous studies that described constitutive UPR activation by overexpression of UPR components (10, 32). Taken together, it could be concluded that protein encoded either wild type or mutant *HAC1* gene displays comparable transcriptional activation property.

Third, the absent of UPR complementation in *hIRE1 $\alpha$*  expressed  $\Delta$ *ire1* yeast clone substantiate the idea of an inability of wild type *HAC1* mRNA splicing by hIre1 $\alpha$ p (10, 29, 32). Similarly, co-expressing wild type *HAC1* with hIre1 $\alpha$ p in the same yeast strain fails to rescue this signaling cascade. However, co-expression of the mutated *HAC1* with hIre1 $\alpha$ p in yeast cells devoid of both endogenous Ire1p and Hac1p restored the ability of this yeast to response to ER stress. In deed, the

phenotype of UPR in this strain resembles to the parental yeast strain, AWY14 containing intact locus of both *IRE1* and *HAC1*. Specifically, low level of UPR activity in non stress condition, but the activity is enhanced dramatically upon ER stress. Analysis of the level of gene transcript by RT-PCR displayed an unexpected result. Both wild type and mutated *HAC1* coexpressed with hIre1 $\alpha$ p showed obviously high level of the unspliced *HAC1* mRNA. Interestingly, very faint band corresponding with spliced *HAC1* mRNA was observed in strain harboring mutated *HAC1* and hIre1 $\alpha$ p plasmid under stress-induced condition. The same results were also observed from northern blot analysis. These results imply that mutated *HAC1* mRNA was spliced although poorly by hIre1 $\alpha$ p *in vivo*. Although the RNA can be cleaved with better efficiency *in vitro*, the splicing happened *in vivo* requires additional factor such as tRNA ligase. This activity is essential in the step of joining the two exons together. It was proposed that tRNA ligase might work cooperatively with Ire1p at nuclear pore where *HAC1* mRNA exits from the nucleus (37). If such cooperative action requires specific extensive interaction between the two players, substitution of yeast Ire1p with hIre1 $\alpha$ p might lack such ability. If this is the case one might expect to see intermediate RNA that fails to be joined. Nevertheless, it is also possible that the intermediate RNA may be extremely unstable in the cell since they lack modification such as poly A tail or Cap modification to stabilize the molecule. Hence the intermediate RNA may be destroyed rapidly in the cells.

Fourth, investigation for the expression efficiency of all plasmid derived genes used in this system was performed by RT-PCR approach. There was no significant difference in expression level of gene derived from the counterpart plasmids. All genes appeared to express at high level. However, we were unable to detect the protein product particularly yeast Ire1p and hIre1 $\alpha$ p (data not show). In many cases the protein level are not correlated directly to the transcript, particularly for exogenous gene such as hIre1 $\alpha$ p in which it may contain biased codon usage rarely used in yeast cells. The fact that hIre1 $\alpha$ p co-expressed with mutant *HAC1* in yeast cells can restore the UPR was a good indication that functional hIre1 $\alpha$ p can be synthesized in these cells. In fact, the similar phenotype of this strain compared to its parental wild type strain, AWY14, suggested that the mechanism by which hIre1 $\alpha$ p

uses in the UPR signaling is very similar to that used by yeast Ire1p. These findings were in agreement with previous study by Liu *et al* (24, 25) who demonstrated that the luminal domain of hIre1 $\alpha$ p that play an important role in monitoring the level of unfolded protein in the ER of mammalian cells exerts the same function in yeast cells.

Finally, the result in this study also demonstrated that the unconventional splicing of mutant *HAC1* mRNA by stress receptor protein hIre1 $\alpha$ p still remain as the major bottleneck step as could be observed from significant difference in level of spliced *HAC1* RNA generated by yeast Ire1p and hIre1 $\alpha$ p. The  $\beta$ -galactosidase assay also revealed that under stress condition the UPR complementation of mutated *HAC1* and hIre1 $\alpha$ p comparable to the activity from wild type *HAC1* and yeast Ire1p cells. It is suggested that the splicing of UPR activation is not directly correlated to the level of spliced *HAC1* mRNA dose-dependent manner. Only minute quantity of spliced *HAC1* can efficiently mediate the UPR activation in the cells. This result implies that only small amount of Hac1p protein is required to initiate full activation of the UPR pathway.

## CHAPTER 7

### CONCLUSION

This study elucidated the relationship of the nucleotide at +1 position of 3' splice region of *HAC1* RNA with the catalytic activity of hIre1 $\alpha$ . From the nucleotide sequence comparison, the similarity of nucleotide sequences between 3' splice regions of yeast *HAC1* to 5' splice junction of human *XBP-1* mRNA was demonstrated. Single nucleotide substitution from adenine to cytosine at the +1 position of 3' spliced site of *HAC1* alters this stem loop to be susceptible to hIre1 $\alpha$  endonuclease *in vitro*. Such mutation on *HAC1* gene has no effect on the property of its gene product. The RNA is undergone stress regulated splicing mechanism normally by yeast Ire1p under ER stress as detected by RT-PCR. The unconventional splicing of mutant *HAC1* mRNA by stress receptor protein hIre1 $\alpha$  still remain the limiting step *in vivo* resulting in significant minus level of the spliced RNA can be generated. Hence, the absent of UPR complementation in *hIRE1 $\alpha$*  expressed  *$\Delta$ ire1* yeast confirms that the inability of hIre1 $\alpha$  to initiate splicing wild type *HAC1* mRNA is due to different specificity of the endonuclease activity. The *in vivo* interaction between mutated *HAC1* and hIre1 $\alpha$  verified in  *$\Delta$ hac1/ $\Delta$ ire1* yeast cells reveals an inefficient splicing of mutant *HAC1* with hIre1 $\alpha$ . This spliced RNA is sufficient to activate maximum induction of UPR *LacZ* reporter. These results lead to identification of the crucial role of nucleotide in +1 position of in the stem loop structure of RNA substrate that must be spliced out prior to being translated into a functional effector in the UPR pathway.

## REFERENCES

1. Thomas PJ, Qu BH, Pederson PL. Defective protein folding as a basis of human disease. *Trends Biochem. Sci.* 1995; 20: 456-459.
2. Kaufman RJ. Orchestrating the unfolded protein response in health and disease. *J.Clin.Invest.* 2002; 110:1389-1398.
3. Selkoe DJ. Folding proteins in fatal ways. *Nature.* 2003; 426: 900-904.
4. Nelson DL, Cox MM. *Lehninger Principle of Biochemistry*. 3<sup>rd</sup> edition. Worth Publishers, New York 2000.
5. Cooper GM. *The Cell: A Molecular Approach*. 4<sup>th</sup> edition. ASM Press, Washington D.C. 2000.
6. Albert B, Johnson A, Lewis J, Raff M, Roberts K, Walter P. *Molecular Biology of the Cell*. 4<sup>th</sup> edition. Garland Publishing, New York 2002.
7. Lewin B. *Genes VII*. Oxford University Press and Cell Press, New York 2000.
8. Normington K, Kohno K, Kozutsumi Y, Gething MJ, Sambrook J. *S. cerevisiae* encodes an essential protein homologous in sequence and function to mammalian BiP. *Cell.* 1989; 57: 1223-1236.
9. Rose MD, Misra LM, Vogel JP. *KAR2*, a karyogamy gene, is the yeast homolog of the mammalian BiP/GRP78 gene. *Cell.* 1989; 57: 1211-1221.
10. Cox JS, Shamu CE, Walter P. Transcriptional induction of genes encoding endoplasmic reticulum resident proteins requires a transmembrane protein kinase. *Cell.* 1993;73:1197-1206.
11. Partaledis JA, Berlin V. The *FKB2* gene of *Saccharomyces cerevisiae*, encoding the immunosuppressant-binding protein FKBP-13 is regulated in response to accumulation of unfolded protein in the endoplasmic reticulum. *Proc. Natl. Acad. Sci.* 1993; 90: 5450-5454.

12. Tachibana C, Stevens TH. The yeast *EUG1* gene encodes an endoplasmic reticulum protein that is functionally related to protein disulfide isomerase. *Mol. Cell. Biol.* 1992; 12: 4601-4611.
13. Schlenstedt G, Harris S, Risse B, Lill R, Silver PA. A yeast DnaJ homologue, Scj1p, can function in the endoplasmic reticulum with BiP/Kar2p via a conserved domain that specifies interactions with Hsp70s. *J Cell. Biol.* 1995; 129: 979-988.
14. Gass JN, Gifford NM, Brewer JW. Activation of an unfolded protein response during differentiation of antibody-secreting Bcells. *J. Biol. Chem.* 2002; 277 (50): 49047-49054.
15. Little E, Tocco G, Baudry M, Lee AS, Schreiber SS, Induction of glucose-regulated protein (glucose-regulated protein 78/BiP and glucose-regulated protein 94) and heat shock protein 70 transcripts in the immature rat brain following status epilepticus. *Neuroscience.* 1996; 75: 209-219.
16. Gething M, Sambrook J. Protein folding in the cell. *Nature.* 1992; 355: 33-45.
17. Shamu CE, Cox JS, Walter P. The unfolded-protein-response pathway in yeast. *Trends Cell Biol.* 1994;4:56-60.
18. Kaufman RJ. Stress signaling from the lumen of the endoplasmic reticulum: coordination of gene transcriptional and translational controls. *Genes Dev.* 1999;13:1211-33.
19. Morishima N, Nakanishi K, Takenouchi H, Shibata T, Yasuhiko Y. An endoplasmic reticulum stress-specific caspase cascade in apoptosis. *J. Biol. Chem.* 2002; 277 (37): 34287-34294.
20. Travers KJ, Patil CK, Wodicka L, Lockhart DJ, Weissman JS, Walter P. Functional and genomic analyses reveal an essential coordination between the unfolded protein response and ER-associated degradation. *Cell.* 2000;101:249-258.
21. Mori K, Ma W, Gething MJ, Sambrook J. A transmembrane protein with a cdc2+/CDC28-related kinase activity is required for signaling from the ER to the nucleus. *Cell* 1993;74:743-56.

22. Nikawa JI, Yamashita S. *IRE1* encodes a putative protein kinase containing a membrane-spanning domain and is required for inositol phototrophy in *Saccharomyces cerevisiae*. *Mol. Microbiol.* 1992; 6: 1441–1446.
23. Okamura K, Kimata Y, Higashio H, Tsuru A, Kohno K. Dissociation of Kar2p/BiP from an ER sensory module Ire1p, triggers the unfolded protein response in yeast. *Biochem. Biophys. Res. Comm.* 2000; 279: 445-450.
24. Liu CY, Schroder M, Kaufman RJ. Ligand-independent dimerization activates the stress response kinases *IRE1* and *PERK* in the lumen of the endoplasmic reticulum. *J. Biol. Chem.* 2000; 275: 24881-5.
25. Liu CY, Wong HN, Schauer JA, Kaufman RJ. The protein kinase/endoribonuclease *IRE1*  $\alpha$  that signals the unfolded protein response has a luminal N-terminal ligand-independent dimerization domain. *J. Biol. Chem.* 2002; 277: 18346-56.
26. Urano F, Bertolotti A, Ron D. *IRE1* and efferent signaling from the endoplasmic reticulum. *J Cell Sci.* 2000; 113 Pt 21: 3697-702.
27. Shamu CE, Walter P. Oligomerization and phosphorylation of the Ire1p kinase during intracellular signaling from the endoplasmic reticulum to the nucleus. *EMBO J.* 1996; 15: 3028-3039.
28. Welihinda AA, Kaufman RJ. The unfolded protein response pathway in *Saccharomyces cerevisiae*. Oligomerization and trans-phosphorylation of Ire1p (Ern1p) are required for kinase activation. *J. Biol. Chem.* 1996; 271: 18181-7.
29. Tirasophon W, Welihinda AA, Kaufman RJ. A stress response pathway from the endoplasmic reticulum to the nucleus requires a novel bifunctional protein kinase/endoribonuclease (Ire1p) in mammalian cells. *Genes Dev.* 1998; 12: 1812-24.
30. Welihinda AA, Tirasophon W, Green SR, Kaufman RJ. Protein serine/threonine phosphatase Ptc2p negatively regulates the unfolded-protein response by dephosphorylating Ire1p kinase. *Mol. Cell Biol.* 1998; 18: 1967-77.

31. Sidrauski C, Walter P. The transmembrane kinase Ire1p is a site-specific endonuclease that initiates mRNA splicing in the unfolded protein response. *Cell*. 1997;90:1031-1039.
32. Cox JS, Walter P. A novel mechanism for regulating activity of a transcription factor that controls the unfolded protein response. *Cell*. 1996;87:391-404.
33. Mori K, Kawahara T, Yoshida H, Yanagi H, Yura T. Signaling from endoplasmic reticulum to nucleus: Transcription factor with a basic-leucine zipper motif is required for the unfolded protein-response pathway. *Genes Cells* 1996; 1: 803–817.
34. Nikawa J, Akiyoshi M, Hirata S, Fukuda T. *Saccharomyces cerevisiae* *IRE2/HAC1* is involved in *IRE1*-mediated *KAR2* expression. *Nucleic Acids Res*. 1996; 24: 4222–4226.
35. Kawahara T, Yanagi H, Yura T, Mori K. Unconventional splicing of *HAC1/ERN4* mRNA required for the unfolded protein response. Sequence-specific and non-sequential cleavage of the splice sites. *J Biol Chem*. 1998;273:1802-7.
36. Kawahara T, Yanagi H, Yura T, Mori K. Endoplasmic reticulum stress-induced mRNA splicing permits synthesis of transcription factor Hac1p/Ern4p that activates the unfolded protein response. *Mol. Biol Cell* 1997;8:1845-62.
37. Sidrauski C, Cox JS, Walter P. tRNA ligase is required for regulated mRNA splicing in the unfolded protein response. *Cell*. 1996;87:405-413.
38. Mori K, Ogawa N, Kawahara T, Yanagi H, Yura T. mRNA splicing-mediated C-terminal replacement of transcription factor Hac1p is required for efficient activation of the unfolded protein response. *Proc. Natl. Acad. Sci. U.S.A* 2000;97:4660-5.
39. Chapman RE, Walter P. Translational attenuation mediated by an mRNA intron. *Curr Biol*. 1997;7:850-859.

40. Mori K, Sant A, Kohno K, Normington K, Gething MJ, Sambrook JF. A 22 bp *cis*-acting element is necessary and sufficient for the induction of the yeast *KAR2* (BiP) gene by unfolded proteins. *EMBO J.* 1992; 11: 2583-2593.
41. Mori K, Kawahara T, Yoshida H, Yanagi H, Yura T. Signalling from endoplasmic reticulum to nucleus: transcription factor with a basic-leucine zipper motif is required for the unfolded protein-response pathway. *Genes Cells* 1996;1:803-17.
42. Mori K, Ogawa N, Kawahara T, Yanagi H, Yura T. Palindrome with spacer of one nucleotide is characteristic of the *cis*-acting unfolded protein response element in *Saccharomyces cerevisiae*. *J Biol Chem.* 1998;273:9912-20.
43. Patil C, Walter P. Intracellular signaling from the endoplasmic reticulum to the nucleus: the unfolded protein response in yeast and mammals. *Curr Opin Cell Biol.* 2001;13:349-355.
44. Gonzalez TN, Sidrauski C, Dorfler S, Walter P. Mechanism of non-spliceosomal mRNA splicing in the unfolded protein response pathway. *EMBO J.* 1999;18:3119-3132.
45. Yoshida H, Matsui T, Yamamoto A, Okada T, Mori K. *XBPI* mRNA is induced by *ATF6* and spliced by *IRE1* in response to ER stress to produce a highly active transcription factor. *Cell* 2001;107:881-91.
46. Calfon M, Zeng H, Urano F et al. *IRE1* couples endoplasmic reticulum load to secretory capacity by processing the *XBPI* mRNA. *Nature* 2002;415:92-6.
47. Shen X, Ellis RE, Lee K, Liu CY, Yang K, Solomon A, Yoshida H, Morimoto R, Kurnit D, Mori K, Kaufman RJ. Complementary signaling pathways regulate the unfolded protein response and are required for *C. elegans* development. *Cell* 2001;107:893-903.
48. Plongthongkum N, Tirasophon W. Characterization of a putative *Drosophila* *XBPI*: a transcription factor regulated by unfolded preprotein response pathway (UPR). Thesis. 2004. Mahidol University.

49. Foti DM, Welihinda A, Kaufman RJ, Lee AS. Conservation and divergence of the yeast and mammalian unfolded protein response. Activation of specific mammalian endoplasmic reticulum stress element of the *grp78/BiP* promoter by yeast *Hac1p*. 1999. *J.Biol.Chem.* 1999; 274: 30402-30409.
50. Harding HP, Calton M, Urano F, Novoa I, Ron D. Transcriptional and translational control in the Mammalian unfolded protein response. *Annu.Rev.Cell Dev.Biol* 2002;18:575-99.
51. Yoshida H, Haze K, Yanagi H, Yura T, Mori K. Identification of the *cis*-acting endoplasmic reticulum stress response element responsible for transcriptional induction of mammalian glucose-regulated proteins. Involvement of basic leucine zipper transcription factors. *J Biol Chem.* 1998; 273: 33741-9.
52. Bertolotti A, Ron D. Alterations in an *IRE1*-RNA complex in the mammalian unfolded protein response. *J Cell Sci.* 2001;114:3207-12.
53. Yoshida H, Okada T, Haze K, Yanagi H, Yura T, Negishi M, Mori K. *ATF6* activated by proteolysis binds in the presence of NF-Y (CBF) directly to the *cis*-acting element responsible for the mammalian unfolded protein response. *Mol. Cell. Biol.* 2000, 20; 6755-6767.
54. Wang XZ, Harding HP, Zhang Y, Jolicoeur EM, Kuroda M, Ron D. Cloning of mammalian *Ire1* reveals diversity in the ER stress responses. *EMBO J* 1998;17:5708-17.
55. Bertolotti A, Wang X, Novoa I, Jungreis R, Schlessinger K, Cho JH, West AB, Ron D. Increased sensitivity to dextran sodium sulfate colitis in *IRE1 $\beta$* -deficient mice. *J. Clin. Invest.* 2001; 107: 585-593.
56. Bowring C, Llewellyn D. Differences in *HAC1* mRNA processing and translation between yeast and mammalian cell indicate divergence of the eukaryotic ER stress response. *Biochem. Biophys. Res. Comm.* 2001; 287: 789-800.
57. Niwa M, Sidrauski C, Kaufman RJ, Walter P. A role for presenilin-1 in nuclear accumulation of *Ire1* fragments and induction of the mammalian unfolded protein response. *Cell.* 1999; 99: 691-702.

58. Hanahan D. Studies on transformation of *Escherichia coli* with plasmid. J. Mol. Biol. 1983; 166: 557-580.
59. Piyaviriyakul P. Production of whole yeast cells containing a high level of intracellular expression of giant catfish growth hormone. Thesis. 1999. Mahidol University.
60. Sambrook J, Russell DW. Molecular Cloning a laboratory manual. 3<sup>rd</sup> edition. Cold Spring Harbor Laboratory Press. New York 2001.
61. Ausubel F, Brent R, Kingston RE, Moore DD, Seigman JG, Smith JA, Struhl K. Current protocols in molecular biology. John Wiley and Sons, Inc. 1998.
62. Gallwitz, D. and Seidel, R. Molecular Cloning of the actin gene from *Saccharomyces cerevisiae*. Nucleic Acid Research 1979; 8(5): 1043-1059.

## **BIOGRAPHY**

<b>NAME</b>	Mr. Pattarawut Sopha
<b>DATE OF BIRTH</b>	January 22 <sup>th</sup> , 1980
<b>PLACE OF BIRTH</b>	Khonkaen, Thailand
<b>INSTITUTION ATTENDED</b>	Srinakarinwirot University, 1998-2001: Bachelor of Sciences (Microbiology) Mahidol University, 2002-2005: Master of Sciences (Molecular Genetics and Genetic Engineering)
<b>RESEARCH GRANTS</b>	Supported by Thailand Research Fund (TRF), The Royal Bangkok Sport Club (RBSC) Postgraduate Scholarship Program and The Pfizer Foundation Scholarship.