

**INFORMATION MANAGEMENT SYSTEM FOR WATER
RESOURCE MANAGEMENT OF HUAI JORAKHE MAK
RESERVOIR BURIRAM PROVINCE**

SOOKTAWEE SINGHTEE

**A THESIS SUBMITTED IN PARTIAL FULFILLMENT
OF THE REQUIREMENTS FOR
THE DEGREE OF MASTER OF SCIENCE
(INFORMATION MANAGEMENT OF ENVIRONMENTS AND
RESOURCES)
FACULTY OF GRADUATE STUDIES
MAHIDOL UNIVERSITY
2007**

COPYRIGHT OF MAHIDOL UNIVERSITY

Thesis
Entitled

**INFORMATION MANAGEMENT SYSTEM FOR WATER
RESOURCE MANAGEMENT OF HUAI CHORAKHE MAK
RESERVOIR BURIRAM PROVINCE**

.....
Mr. Sooktawee Singhtee
Candidate

.....
Assoc. Prof. Suchart Nawagawong, M.Sc.
Major-Advisor

.....
Assoc. Prof. Dr. Sura Pattanakiat, Ph.D.
Co-Advisor

.....
Prof. Dr. M.R. Jisnuson Svasti,
Ph.D.
Dean
Faculty of Graduate Studies

.....
Assoc. Prof. Dr. Anuchat Phoungsomlee,
Ph.D.
Acting Chair
Master of Science Programme in
Information Management on
Environments and Resources
Faculty of Environment and Resource
Studies

Thesis
Entitled

**INFORMATION MANAGEMENT SYSTEM FOR WATER
RESOURCE MANAGEMENT OF HUAI CHORAKHE MAK
RESERVOIR BURIRAM PROVINCE**

was submitted to the Faculty of Graduate Studies, Mahidol University
For the degree of Master of Science
(Information Management on Environments and Resources)

On
May 11, 2007

.....
Mr. Sooktawee Singhtee
Candidate

.....
Mr. Suthep Tangsup, Ph.D,M.Sc.,B.Sc.
Chair

.....
Assoc. Prof. Suchart Nawagawong, M.Sc.
Member

.....
Assoc. Prof. Dr. Sura Pattanakiat, Ph.D.
Member

.....
Prof. Dr. M.R. Jisnuson Svasti,
Ph.D.
Dean
Faculty of Graduate Studies
Mahidol University

.....
Assoc. Prof. Dr. Anuchat Phoungsomlee,
Ph.D.
Dean
Faculty of Environment and Resource
Studies
Mahidol University

ACKNOWLEDGEMENT

For the achievement of my thesis, I would like to express my gratitude to these following people:

First, I would like to thank my major-advisor Assoc. Prof. Suchart Nawagawong who always care and worry about everything of my thesis. He assign so many jobs of project that I can do both with my thesis. And he always approach a thesis problem and the need to be persistent to accomplish any gold. I really appreciate the Assoc. Prof. Dr. Sura Pattanakiat, Dr. Suthep Tangsup, Arjan Kanjanadin Sarapratoom for their kindness and helpful suggestion in my thesis.

Next I would like to Thank for all staff and administrator at Huai Jorakhe mak reservoir at Buriram province who give me the document data and information of irrigator information.

I would like to thanks all of my friends IM11 to be good friend and give me all willpower for me. Also with K. Pla from RSU who is help me for confused about my thesis translator, Nong Oat who is correct thesis comment, Nong Dao, Nong Tukata, golf, Tee who take me lunch everyday.

Most of all, I'm dedicate give with a father a person from this world has gone. And pleased for my achievement and thesis to my parents their giving me life and love, for unconditional support, for listening to my complaints and frustrations, for care and understanding, for believing in me.

Last, but not least, I would like thank for Web Maker Co.,Ltd. Who always give me work of freelance it supported my income. And I would like to thank of myself for and everyone come in my life and make my dream come true.

Sooktawee Singhtee

**INFORMATION MANAGEMENT SYSTEM FOR WATER RESOURCE
MANAGEMENT OF HUAI CHORAKHE MAK RESERVOIR BURIRAM
PROVINCE**

SOOKTAWEE SINGHTEE 4737400 ENIM/M

**M.Sc.(INFORMATION MANAGEMENT ON ENVIRONMENTS AND
RESOURCES)**

**THESIS ADVISORS: SUCHART NAWAGAWONG, M.Sc.(Technology of
Environmental Management); SURA PATTANAKIAT, Ph.D.(Forestry)**

ABSTRACT

The objective of this study was to establish a database and develop a computer programming prototype for water regulation in small scale irrigation project, Huai Jorakhe Mak, Buriram Province. The System Development Life Cycle (SDLC) process and Artificial Neural Network (ANN) were employed in this study.

It was found that the appropriated dataset initiated from the study consisted of daily annual rainfall, daily surface water level, water level assumption, water gate regulation, water supply in local scale, reservoir characteristics, and water for crop requirements. The database management and computer programming development were efficiently operated using Mysql, C and PHP language. The system was mainly operated at the main server and connected to various clients' workstations. It was designed as a semi-automatic system using two level manipulation based upon Neural Network analysis. The simulation model of water regulation according to dynamic data accessed from existing databases was then initiated to support practical water regulation activities.

In addition, attitude evaluation was carried out by interviewing staff from the Huai Jorakhe Mak Small Scale Irrigation Project. It was found that users greatly appreciated the system since it could be utilized in a practical manner and could be applied to real situation.

KEY WORDS: NEURAL NETWORK / INFORMATION MANAGEMENT

SYSTEM / WATER REGULATION / WATER MANAGEMENT

82 P.

ระบบสารสนเทศเพื่อการจัดการทรัพยากรน้ำของอ่างเก็บน้ำห้วยจรเข้มาก จังหวัดบุรีรัมย์
(INFORMATION MANAGEMENT SYSTEM FOR WATER RESOURCE MANAGEMENT OF
HUAI CHORAKHE MAK RESERVOIR BURIRAM PROVINCE)

สุทวิ สิงห์ที 4737400 ENIM/M

วท.ม. (การจัดการสารสนเทศสิ่งแวดล้อมและทรัพยากร)

คณะกรรมการควบคุมวิทยานิพนธ์ : สุชาติ นวกวงษ์, M.Sc. (Technology of Environmental Management); สุระ พัฒนเกียรติ, Ph.D. (Forestry)

บทคัดย่อ

การศึกษานี้มีวัตถุประสงค์ เพื่อจัดทำระบบฐานข้อมูลและพัฒนาต้นแบบโปรแกรมระบบคอมพิวเตอร์ เพื่อการจัดสรรน้ำในโครงการชลประทานขนาดเล็ก ห้วยจรเข้มาก จังหวัดบุรีรัมย์ โดยประยุกต์ใช้การพัฒนาวงจรชีวิต (System Development Life Cycle: SDLC) และ ทฤษฎีโครงข่ายประสาทเทียม (Neural Network Theory) ซึ่งเป็นระบบปัญญาประดิษฐ์ (Artificial Intelligent) รูปแบบหนึ่งที่เหมาะสมกับการพยากรณ์ล่วงหน้า

จากการศึกษาพบว่า ฐานข้อมูลที่จัดสร้างในการศึกษานี้ประกอบด้วย ข้อมูลปริมาณน้ำฝนรายวันในแต่ละปี การเปิดปิดประตูระบายน้ำ ปริมาณระดับน้ำรายวัน การประมาณการของระดับน้ำ ปริมาณน้ำสนับสนุนการใช้ในระดับท้องถิ่น ข้อมูลพื้นฐานของอ่างเก็บน้ำ และปริมาณความต้องการใช้น้ำของพืช การจัดการฐานข้อมูลและการพัฒนาต้นแบบโปรแกรมคอมพิวเตอร์ สามารถดำเนินการได้อย่างมีประสิทธิภาพโดยใช้โปรแกรมระบบฐานข้อมูล Mysql ภาษา C และ PHP ซึ่งทำงานในระบบของสถานีหน่วยจัดการหลัก (Main Server) เชื่อมโยงกับสถานีเครือข่าย (Clients Workstation) โดยระบบสามารถรองรับการวิเคราะห์และคาดการณ์แบบกึ่งอัตโนมัติ เพื่อการจัดสรรน้ำตามทฤษฎีโครงข่ายประสาทเทียมได้เป็นอย่างดี ซึ่งการออกแบบได้แบ่งชั้นของการวิเคราะห์ออกเป็นสองระดับเพื่อสร้างสถานการณ์การสรรน้ำจากฐานข้อมูลที่จัดทำขึ้นเพื่อรองรับการเปลี่ยนแปลงของข้อมูลที่เกิดขึ้น

การประเมินความพึงพอใจของผู้ใช้ระบบซึ่งเป็นเจ้าหน้าที่ของโครงการชลประทานขนาดเล็ก ห้วยจรเข้มาก จังหวัดบุรีรัมย์ พบว่า มีความพึงพอใจในระดับมาก โดยระบบสามารถนำไปใช้ในการจัดสรรน้ำได้ดี มีทิศทางของการระบายน้ำสอดคล้องกับการระบายน้ำที่เป็นจริงตามการดำเนินการของสำนักงานชลประทานขนาดเล็ก ห้วยจรเข้มาก

CONTENTS

	Page
ACKNOWLEDGEMENTS	iii
ABSTRACT	iv
LIST OF TABLES	ix
LIST OF FIGURES	x
CHAPTER	
I INTRODUCTION	1
1.1 Principles and Reasons	1
1.2 Research Objective	2
1.3 Research Conceptual	2
1.4 Research Boundary	3
1.5 Expected Research Benefits	3
1.6 Research Definitions	4
II LITERATURE REVIEWS	5
2.1 Information System	5
2.2 Concept of Neural Network Theory	10
2.3 Irrigation Efficiency	18
2.4 Crop water requirement by Theories	20
2.5 Concept and Theory of Water Management	22
2.6 Theories and Reservoir Operation Method	24
Reservoir Operation study	
2.7 Huai Jorakhe Mak reservoir data	28
2.8 Literature Review	34

CONTENTS (Cont.)

	Pages
III MATERIALS AND METHODS	36
3.1 Researching Steps and Determine	36
3.2 Studying presently situation and Data Source	37
3.3 Materials	37
3.4 System Develop	38
3.5 Evaluation system	38
IV RESULTS AND DISCUSSION	40
4.1 The result of information and technology requirement	40
4.2 Problem recognition	41
4.3 The solution	41
4.4 The result of collecting the necessary data into system	42
4.5 Design and construction the database	42
4.6 The result of the system design and implementation	41
4.7 Evaluate the information technology system	53
4.8 Re-improvement the system to be corrected and followed the user recommendation	53
4.9 Publish the system introduction	56
4.10 The result of statistics	57
4.11 The commendation of this study	58
4.12 The conclusion	58
V RESULTS CONCLUSIONS AND RECOMMENDATIONS	59
5.1 Research conclusions	59
5.2 Recommendations	60

CONTENTS (Cont.)

REFERENCES	62
APPENDIX	64
BIOGRAPHY	82

LIST OF TABLE

	Page
Table 2.1 Building component of canal	33
Table 2.2 Summary rainfall per year	33
Table 2.3 Summary water regulate per year	34
Table 4.1 System evaluate rank point	57

LIST OF FIGURES

	Page
Figure 1-1 Conceptual Framework	2
Figure 1-2 Variable for research	3
Figure 2-1 System information components	7
Figure 2.2 Neuron Cell	11
Figure 2.3 Neural of Neural Networks	11
Figure 2-4 Algebraic linear	12
Figure 2.5 Algebraic Threshold	12
Figure 2.6 1 division of neural is Activation function component	12
Figure 2.7 Adaline pattern	13
Figure 2-8 Multilayer Perceptron pattern	14
Figure 2-9 Hopfield Network pattern	14
Figure 2-10 Jordan Network pattern	15
Figure 2.11 Supervised Learning Diagram	16
Figure 2-12 UnSupervised Learning Diagram	16
Figure 2-13 Reinforcement Learning diagram	17
Figure 2-14 Water Management Diagram	23
Figure 2-15 Studies area map	28
Figure 2-16 Huai Jorakhe Mak reservoir map	29
Figure 2-17 Huai Jorakhe Mak reservoir	29
Figure 2-18 Huai Jorakhe Mak Reservoir layout canal	32
Figure 4.1 User Requirements (Hardware Feasibility)	43
Figure 4.2 User requirements (Software Feasibility)	44
Figure 4.3 Work Flow Diagram from system analysis	45
Figure 4.4 Context Diagram 0 of flow data	46
Figure 4.5 Data Flow Diagram of the 1 st Section	47

LIST OF FIGURES (Cont.)

	Page
Figure 4.6 Data Flow Diagram of the 2 nd Section	47
Figure 4.7 Data Flow Diagram of the 3 rd Section	47
Figure 4.6 Data Flow Diagram of the 4 th Section	48
Figure 4.9 Neural network diagram for developed design	47
Figure 4.10 User interface design	50
Figure 4.11 Username and Password request form	51
Figure 4.12 Standard screen output display	51
Figure 4.13 Standard input screen and current record display	52
Figure 4.14 Compared results from data simulated model and actual data year 2001 (RMC)	54
Figure 4.15 Compared results from data simulated model and actual data year 2001 (LMC)	54
Figure 4.16 Compared results from data simulated model and actual data year 2003 (RMC)	55
Figure 4.17 Compared results from data simulated model and actual data year 2003 (LMC)	55

CHAPTER I

INTRODUCTION

1.1 Principles and Reasons

Flooded and drought problems are spreading occurred many areas in Thailand, or in the world. The reservoirs are constructed expecting to cover the problem of flooded and drought, they are small and large reservoir. The capacity of the reservoir depends on the water surface and its water storage volume. The storage volume of the reservoir is uncertain. Some years are much enough, while the next might be decreased. However, the reservoir is function as delivery water to support activities; agriculture, industrial, communities and the others.

Buriram province is the land of flooded and drought every year. People are suffered from flooded during the rainy season, while they are trouble during the dry season. Small scale irrigation projects have been constructed in some area to solve the water problem as mentioned.

Huai Jorakhe Mak is a small irrigation project that the Royal Irrigation Department has constructed in Buriram province. It has volume at normal capacity 27,363.000 mcm. and it has inflow 33,840,000 mcm. every year. It is appeared that the irrigated area had been flooded due to water delivery by weir operating. Flooded is occurred suddenly in rainy season, while shortage in dry season. As reviewing, the water is delivered by manual operating the total amount released and regulation is depending on the decision of the project engineer, who is responded the project area. He, the project engineer, can make a decision in any situation. This led to the problem of water regulation and distribution during a year.

The researcher is interested in finding the way of water operation through out the problem. He imagines that the computer_system could be approached to assist the farmers and the irrigated area. The Artificial Neural Network (ANNs) is a method that he would bring to use for the small scale irrigation project like Huai Jorakhe Mak.

The application of the natural as the Artificial Neural Network (ANNs) could be used for water resource prediction. The ANNs could be predicted the operating system for sufficient water for general activities. Not only agricultures, but also they supported for people consumption.

1.2 Research Objective

1.2.2 To develop computer programming prototype to regulate the small scale reservoir by using Artificial Intelligence theory of Neural Network.

1.2.3 To establish the database for the small scale reservoir operation.

1.3 Research Conceptual

This research used the concept of Neural Network via developing reservoir system from learning by nature theory, studied about Neural Network for forecasting and controlling regulate of small scale reservoir, as following:

1.3.1 Studying Neural Network and applied the regulating theory for small scale reservoir.

1.3.2 Creating computer programming using the Neural Network theory.

1.3.3 Testing the process of Neural Network for finding the efficiency of the program.

1.3.4 Implementing that developed program of Neural Network theory to determine water quantity from reservoir regulating operation

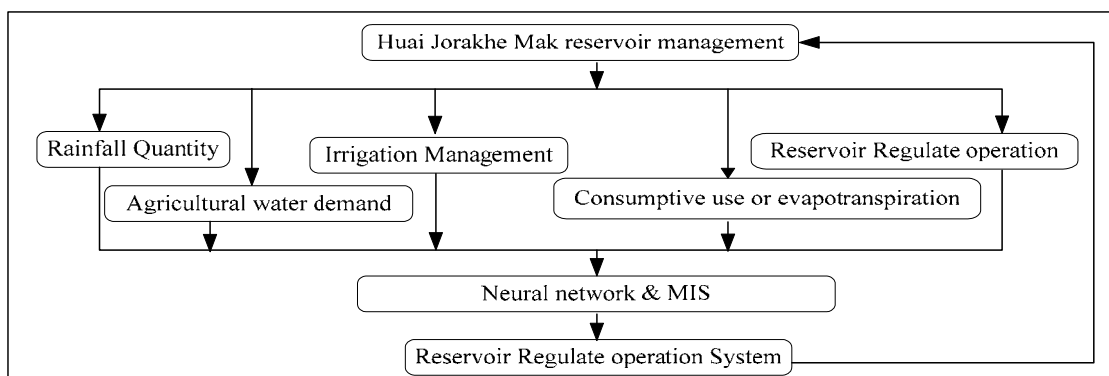

Figure 1-1 Conceptual Framework

The determined variables use to operating regulate of reservoir through Neural Network theory.

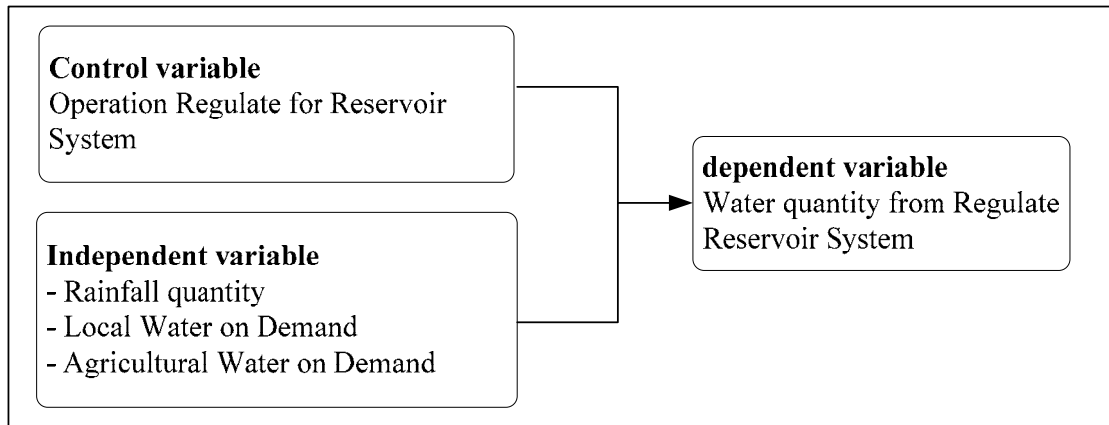

Figure 1-2 Variables for research

1.4 Research Boundary

1.4.1 The area around the Huai Jorakhe Mak reservoir that effected from the reservoir.

1.4.2 The study is insisted to the water quantity of Huai Jorakhe Mak reservoir area that regulate by reservoir.

1.4.3 The program will be evaluated by the officers in the Huai Jorakhe Mak reservoir project.

1.5 Expected Research Benefit

1.5.1 The program operating regulation of the reservoir could be used as the decision making tool for solving the drought and flood problem in that area.

1.5.2 The operating plan of water regulation from the reservoir system will be approached.

1.5.3 The program could be applied to any small scale project where the character is similar.

1.6 Research Definitions

1.6.1 Information System (IS)

The information system is consisted of the component of data that support the processing, management and decision which is objective for responding in business. (1)

1.6.2 Artificial Neural Networks (ANNs)

Neural Network is the one of the Artificial Intelligence. ANNs that develop in the computer era. ANNs is the calculating system that imitate of human brain to use for forecast from existing data such as weather forecasting, stock forecasting in stock exchange. Presently, ANNs was developed for hydrography(2). In other fields such as Image Processing and Pattern Recognition. ANNs has another name, that is Machine Learning Algorithms, Natural Intelligent System.(3)

1.6.3 The Irrigation Efficiency (IE)

It is the parameter that tell about the irrigation system ability in water grid system and maintenance at the source till crop area that up to the consideration of irrigation system ability such as crop level, canal level, large canal or project level.(4)

CHAPTER II

LITERATURE REVIEWS

The literature reviews and theories for correspond of this study as following:

- Information System
- Concept of Neural network theory
- Irrigation Efficiency
- Water quantity for agriculture by theories
- Concept and theory of water management
- Theories of reservoir operation method reservoir operation study
- Huai Jorakhe Mak reservoir data
- Literature review

2.1 Information System

2.1.1 Definitions

An information system can be defined technically as a set of interrelated components that collect, process, store and distribute information to support decision making and control in an organization. In addition to supporting decision making, coordination and control, information system may also help managers and workers analyze problem, visualize complex subjects, and create new products. (1)

Information systems contain information about significant people, places, and things within the organization or in the environment surrounding it.

By information we mean data that have been shaped into a form that is meaningful and useful to human beings. Data, in contrast, are stream of raw facts representing event occur in organizations or the physical environment before they have been organized and arranged into a form that people can understand and use.

Three activities in an information system produce the information organizations need for making decisions, controlling operations, and output.

Input captures are collect raw data from with in the organization or from its external environment. Processing converts this raw input into a more meaningful form.

Output transfers the processed information to the people are activities where it will used. Information systems also require feedback, which is output that is returned to appropriate members of the organization to help them evaluate or correct the input stage.

2.1.2 Components of Information System

Information systems compose the part that Inputs data Processing the part Outputs and the reflection Feedback showing at figure 2.1. An information processor or information processing system, as its name suggests, is a system (be it electrical, mechanical or biological) which takes information (a sequence of enumerated states) in one form and processes (transforms) it into another form, e.g. to statistics, by an algorithmic process.

An information processing system is made up of four basic parts, or sub-systems:

1. Input is the term denoting either an entrance or changes which are inserted into a system and which activate/modify a process. It is an abstract concept, used in the modeling, system(s) design and system(s) exploitation. It is usually connected with other terms, e.g., input variable, input parameter, input value, input signal, input device and input file.

2. Data processing pertaining to the change and modifying data are giving in type of valuable. An example of the data processing for example calculation, comparison, choice filtration in work practice and data saving will keep to use in the future by the data processing can do with oneself or able use the computer comes to solve.

3. Output process like in document form or report a report that present the executive. Output system might use to the part that imports for control the system or the equipment is other. May use the software or computer hardware comes in to help in designing until get original at straight the requirement most. Output process might in printed matters that come out from the printer or show stay on computer monitor that is the equipment shows one or report and a document that write all right manually.

4. The reflection (Feedback) be the part shows that use in causing change the part that input or the part evaluates such as the error is or a problem that happen might have to correct the data input or do data processing change for be proportionate output that be correct.

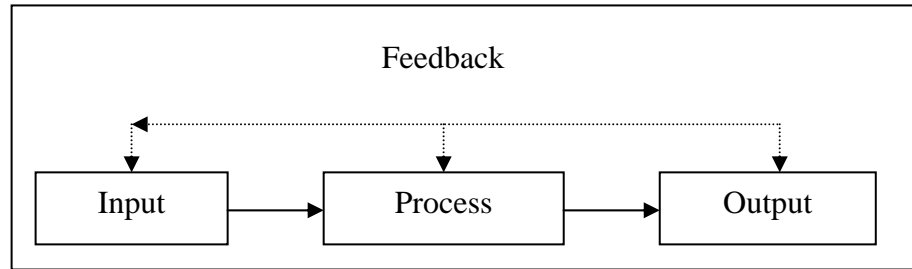

Figure 2-1 System information components
Source : (1)

2.1.3 Systems Development Life Cycle (SDLC)

SDLC is a software development process, although it is also a distinct process independent of software or other Information Technology considerations. It is used by a systems analyst to develop an information system, including requirements, validation, training, and user ownership through investigation, analysis, design, implementation, and maintenance. SDLC is also known as information systems development or application development. An SDLC should result in a high quality system that meets or exceeds customer expectations, within time and cost estimates, works effectively and efficiently in the current and planned information technology infrastructure, and is cheap to maintain and cost-effective to enhance. SDLC is a systematic approach to problem solving and is composed of several phases, SDLC encompasses ten phases:

2.1.3.1 Initiation Phase

The initiation of a system (or project) begins when a business need or opportunity is identified. A Project Manager should be appointed to manage the project. This business need is documented in a Concept Proposal. After the Concept Proposal is approved, the System Concept Development Phase begins.

2.1.3.2 System Concept Development Phase

Once a business need is approved, the approaches for accomplishing the concept are reviewed for feasibility and appropriateness. The

Systems Boundary Document identifies the scope of the system and requires Senior Official approval and funding before beginning the Planning Phase.

2.1.3.3 Planning Phase

The concept is further developed to describe how the business will operate once the approved system is implemented, and to assess how the system will impact employee and customer privacy. To ensure the products and /or services provide the required capability on-time and within budget, project resources, activities, schedules, tools, and reviews are defined. Additionally, security certification and accreditation activities begin with the identification of system security requirements and the completion of a high level vulnerability assessment.

2.1.3.4 Requirements Analysis Phase

Functional user requirements are formally defined and delineate the requirements in terms of data, system performance, security, and maintainability requirements for the system. All requirements are defined to a level of detail sufficient for systems design to proceed. All requirements need to be measurable and testable and relate to the business need or opportunity identified in the Initiation Phase.

2.1.3.5 Design Phase

The physical characteristics of the system are designed during this phase. The operating environment is established, major subsystems and their inputs and outputs are defined, and processes are allocated to resources. Everything requiring user input or approval must be documented and reviewed by the user. The physical characteristics of the system are specified and a detailed design is prepared. Subsystems identified during design are used to create a detailed structure of the system. Each subsystem is partitioned into one or more design units or modules. Detailed logic specifications are prepared for each software module.

2.1.3.6 Development Phase

The detailed specifications produced during the design phase are translated into hardware, communications, and executable software. Software shall be unit tested, integrated, and retested in a systematic manner. Hardware is assembled and tested.

2.1.3.7 Integration and Test Phase

The various components of the system are integrated and systematically tested. The user tests the system to ensure that the functional requirements, as defined in the functional requirements document, are satisfied by the developed or modified system. Prior to installing and operating the system in a production environment, the system must undergo certification and accreditation activities.

2.1.3.8 Implementation Phase

The system or system modifications are installed and made operational in a production environment. The phase is initiated after the system has been tested and accepted by the user. This phase continues until the system is operating in production in accordance with the defined user requirements.

2.1.3.9 Operations and Maintenance Phase

The system operation is ongoing. The system is monitored for continued performance in accordance with user requirements, and needed system modifications are incorporated. The operational system is periodically assessed through In-Process Reviews to determine how the system can be made more efficient and effective. Operations continue as long as the system can be effectively adapted to respond to an organization's needs. When modifications or changes are identified as necessary, the system may reenter the planning phase.

2.1.3.10 Disposition Phase

The disposition activities ensure the orderly termination of the system and preserve the vital information about the system so that some or all of the information may be reactivated in the future if necessary. Particular emphasis is given to proper preservation of the data processed by the system, so that the data is effectively migrated to another system or archived in accordance with applicable records management regulations and policies, for potential future access.

2.1.4 Management Information System (MIS)

The system that help in report preparation for level executive use in practice work supervision. The executive has to use the information manages with a problem such as use in error analysis, progress, or faults in the work include program from creating extending program and system process by data management and input

storage into database. And output report to information management in other form on exclusive need. If the information management is system to storage input within organization and outside information for help exclusive to decision, analysis, solve problem, and control work process.(5)

2.1.5 Information management system benefits

The advantage of information management system can summarize into 5 the issues as follows:

1.To increase efficiency in the work in case of an organization as the routine must do everyday and work enhance an officer or enhance the work.

2. Enhance the quality services of an organization that has a business in working character can use information system to offer the convenience in the connection of a customer.

3.Help the work in permanent character make fast work goes up the accurate and give an officer has learnt new work for information data will can forecast a problem has sought in advance make can plan in situation supervision has and the administration in advance.

4. The executive members who lead the information can build the strategy in the work.

5.The Information development is updated all the time making the organization has the New Technology to pulling customers impressing service.

2.2 Concept of Neural Network theory

An Artificial Neural Network (ANN) is an information processing paradigm that is inspired by the way biological nervous systems, such as the brain, process information. The key element of this paradigm is the novel structure of the information processing system. It is composed of a large number of highly interconnected processing elements (neurones) working in unison to solve specific problems. ANNs, like people, learn by example. An ANN is configured for a specific application, such as pattern recognition or data classification, through a learning process. Learning in biological systems involves adjustments to the synaptic connections that exist between the neurones.(2)

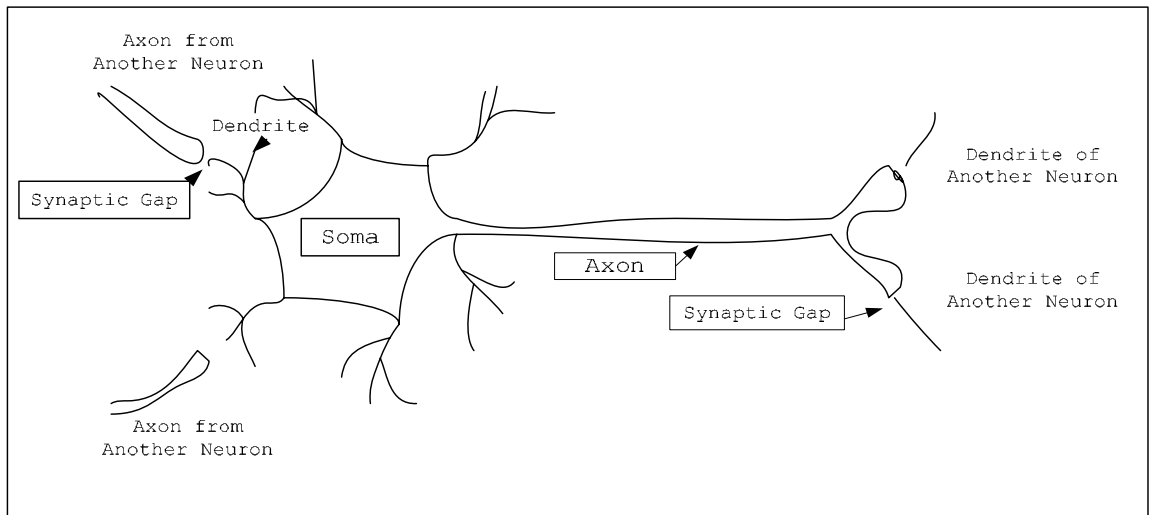

Figure 2.2 Neuron Cell

Consist of dendrites that branching from cell body and connects to other neuron cell that this point have the synapse which adjust when input value pass synapse and assemble at cell body and neural cell. Output will send via Axon following the combination's characteristics of input cell.

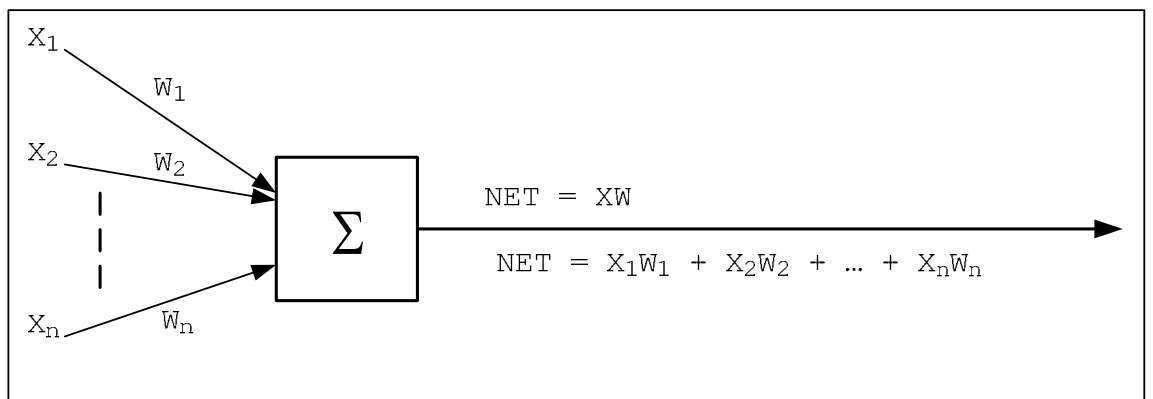

Figure 2.3 Neural of Neural Network

Similar with Neuron Cell that is weight that can adjust value synapse

$$NET = X_1W_1 + X_2W_2 + \dots + X_nW_n$$

Or in the format of vector as follows;

$$NET = XW$$

By

$$X = \text{Input vector}$$

$$W = \text{Weight vector}$$

$$NET = \text{Output vector}$$

Normally, output value will perform call activation function that have many pattern in linear equation,

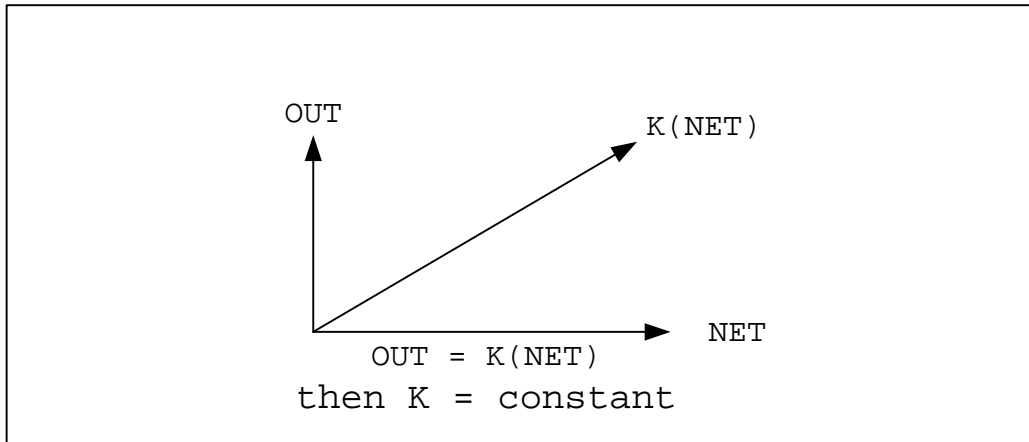

Figure 2-4 Algebraic linear

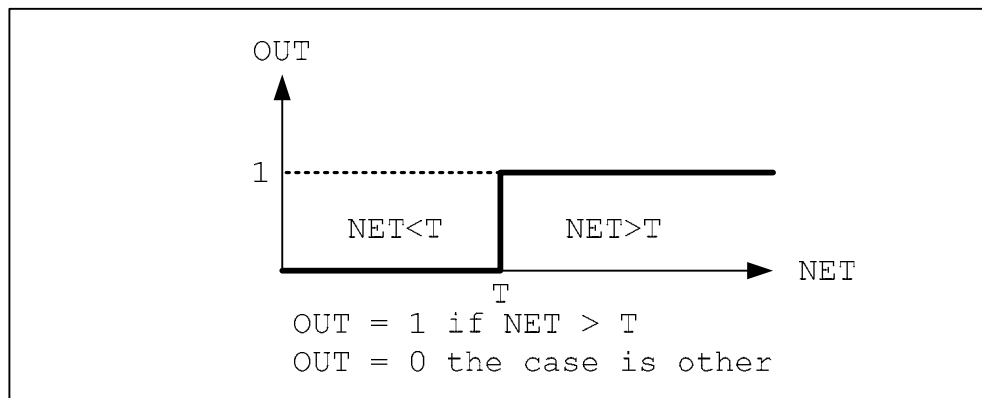

Figure 2.5 Algebraic Threshold

More over, it is possible in another function pattern like Non-linear function shown as figure 2-6.

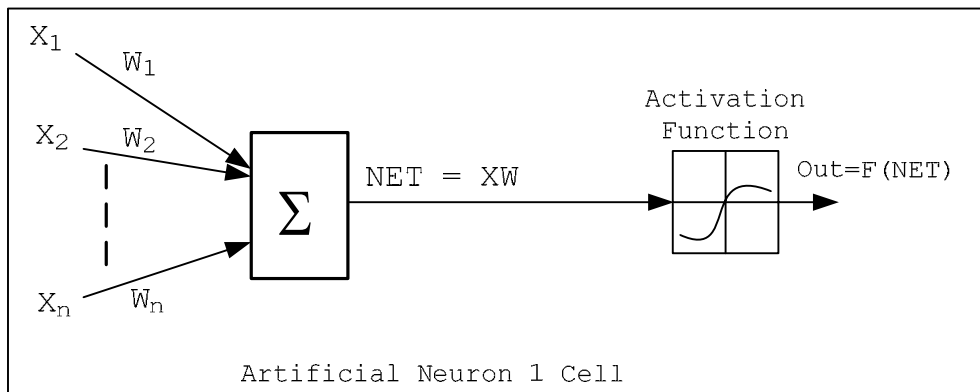

Figure 2.6 1 division of neural is activation function component

2.2.1 Neural Network Categories

Information transfer across a synapse is controlled by bio-chemical agents but a process that is modeled in electronic neurons by the changing of synaptic weight. It is estimated that the brain contains in the order of 10¹¹ neurons, and 10¹⁴ to 10¹⁶ synaptic interconnections among these. Neuron network consist of unit processing call Neuron join as network which specify neuron network structure.

2.2.1.1 Structure Categorization

Structure categorization neural network is considered from movement direction of data signal can divide get 2 a kind as follows:

1. Feed-forward networks

Feed-forward networks, neurons were group in some layer and the signal will directly pass from input layer through hidden layer through output layer. The connecting will layer to next layer.

Feed-forward networks are advantageous as they are the fastest models to execute, and as mentioned before are universal function approximators. One major disadvantage of this network type, is that no fast and reliable algorithm has yet been designed and therefore can be extremely slow to train.

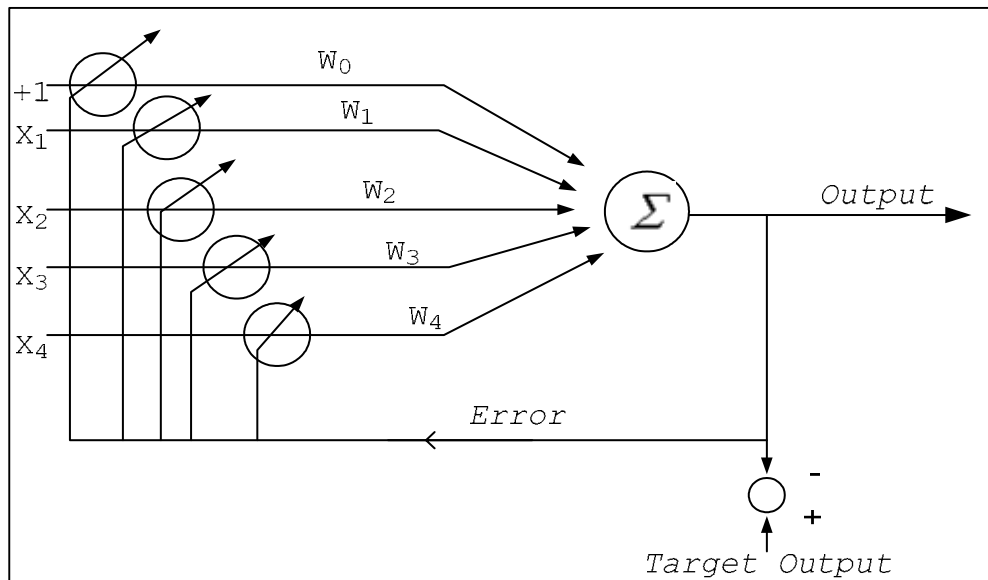

Figure 2.7 Adaline pattern

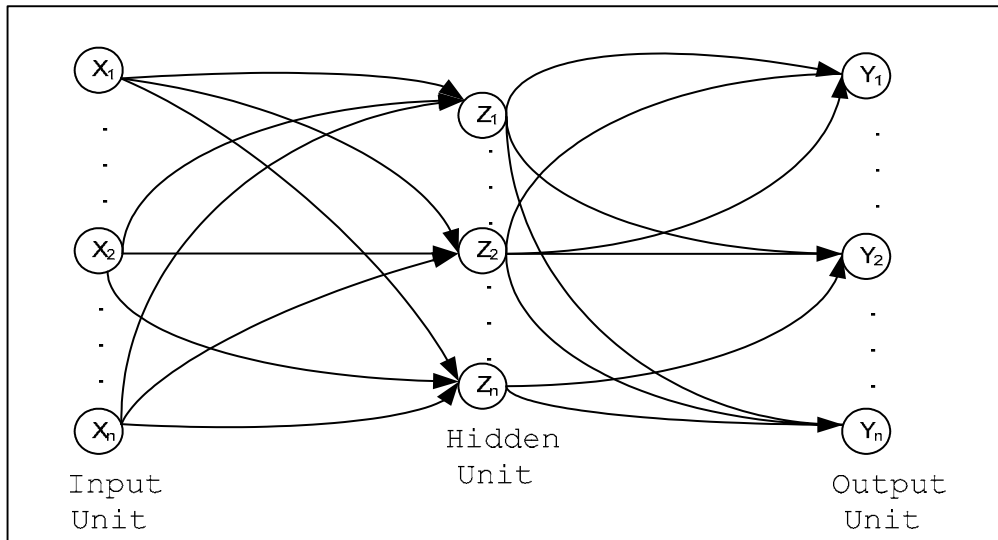

Figure 2-8 Multilayer perceptron pattern

2. Recurrent Network

Recurrent Network, signal move into 2 directions, forward and backward by the way some neuron output will move backward to them self or move to previous layer such as hop-field network shown as following:

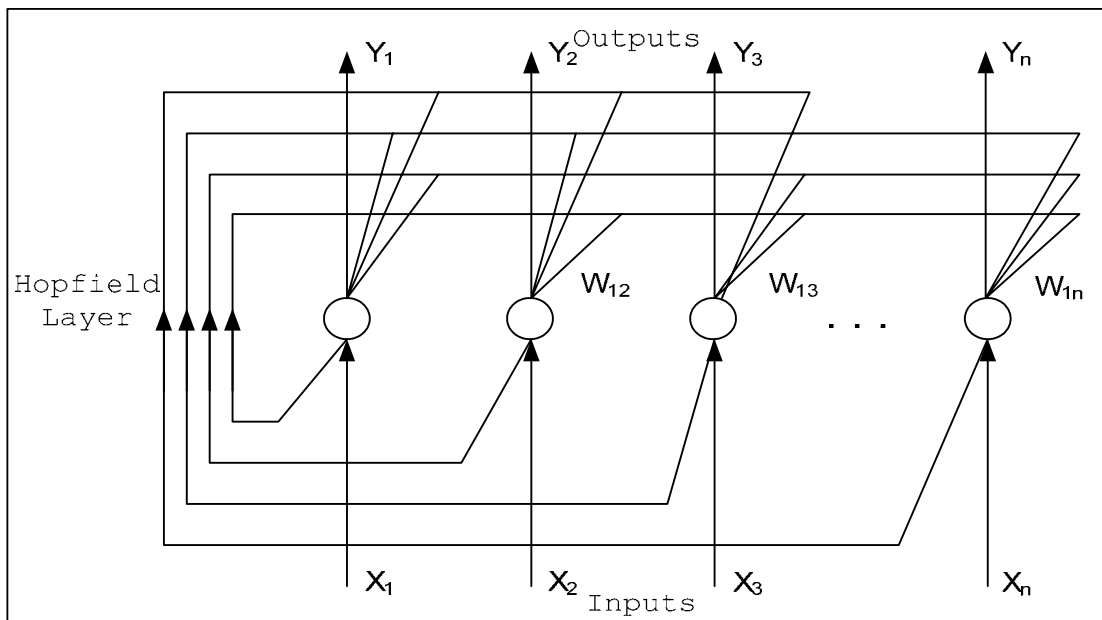

Figure 2-9 Hop field Network pattern

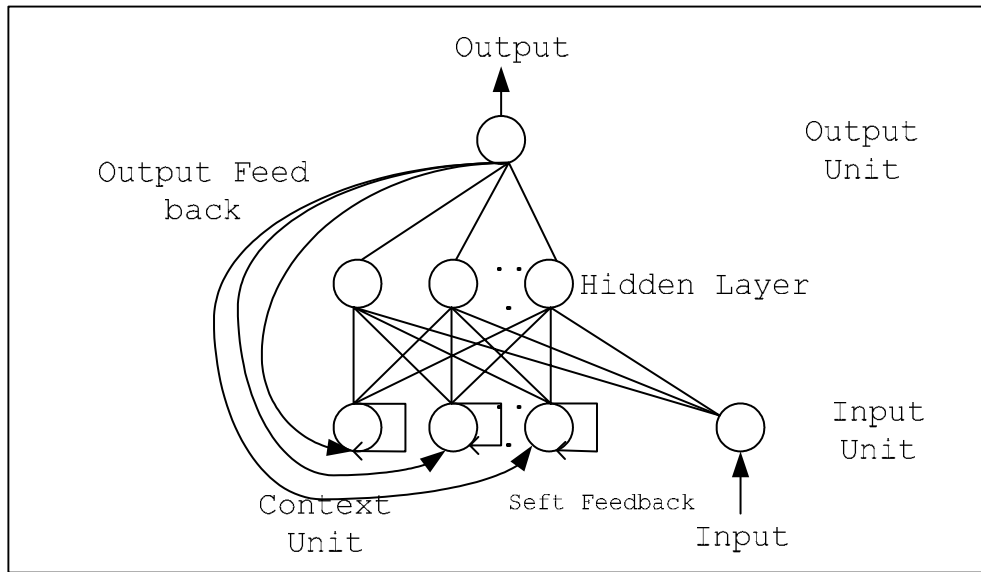

Figure 2-10 Jordan network pattern

2.2.2 Learning Algorithm Categorization

Learning Algorithm is algorithm that is used for adjust network to learn row weight to objectives, to get the output that nearly or equal output. Learning algorithm has 3 types as following:

2.2.2.1 Supervised Learning

Supervised learning is a machine learning technique for creating a function from training data. The training data consist of pairs of input objects (typically vectors), and desired outputs. The output of the function can be a continuous value (called regression), or can predict a class label of the input object (called classification). The task of the supervised learner is to predict the value of the function for any valid input object after having seen a number of training examples (i.e. pairs of input and target output). To achieve this, the learner has to generalize from the presented data to unseen situations in a "reasonable" way (see inductive bias). (Compare with unsupervised learning.) The parallel task in human and animal psychology is often referred to as concept learning.

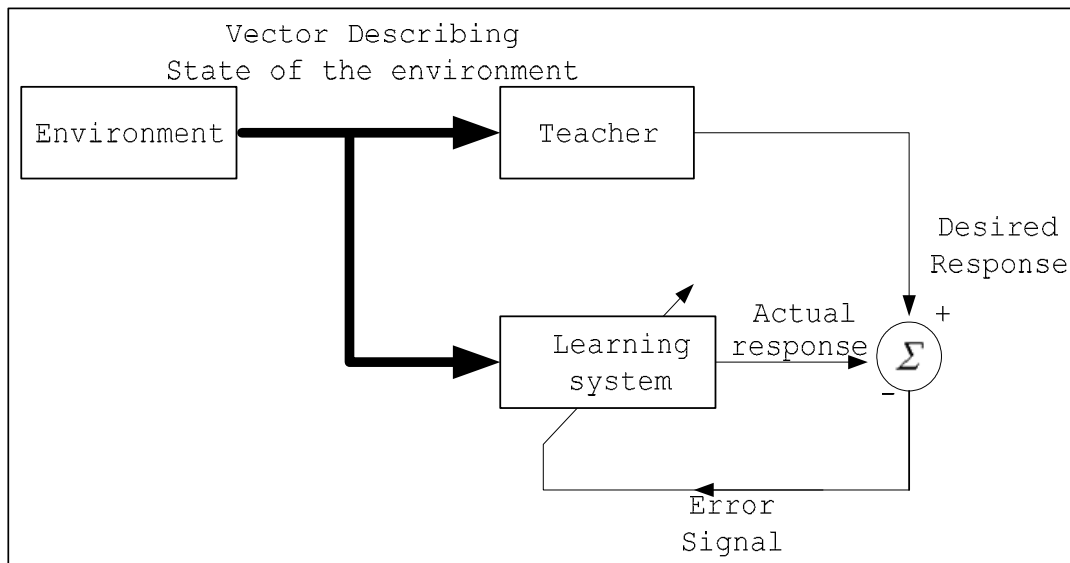

Figure 2.11 Supervised learning diagram

2.2.2.2 Unsupervised learning

Unsupervised learning is no need output object for adjust of network learning. Only input data is imported into network. So automatic weight for making group input similar is same group shown as figure 2-12.

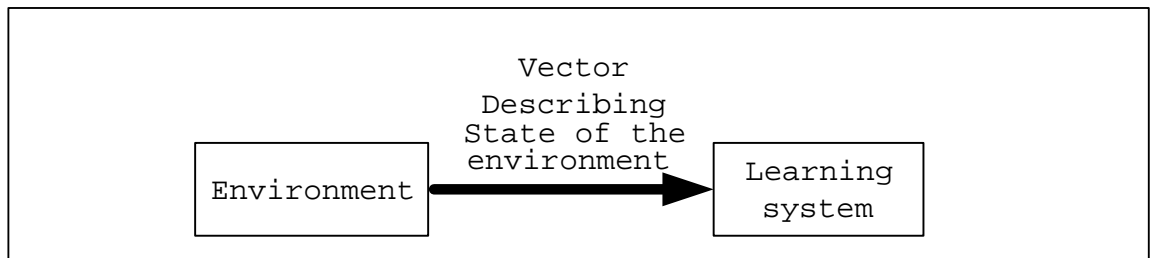

Figure 2-12 Unsupervised learning diagram

2.2.2.3 Reinforcement Learning

Reinforcement learning is a type of special supervised learning. It is no output object but it use critic for evaluate to object output. Reinforcement learning is learning what to do--how to map situations to actions--so as to maximize a numerical reward signal. The learner is not told which actions to take, as in most forms of machine learning. Reinforcement learning is defined not by characterizing learning methods, but by characterizing a learning problem. Reinforcement learning is different from supervised learning, the kind of learning studied in most current research in machine learning

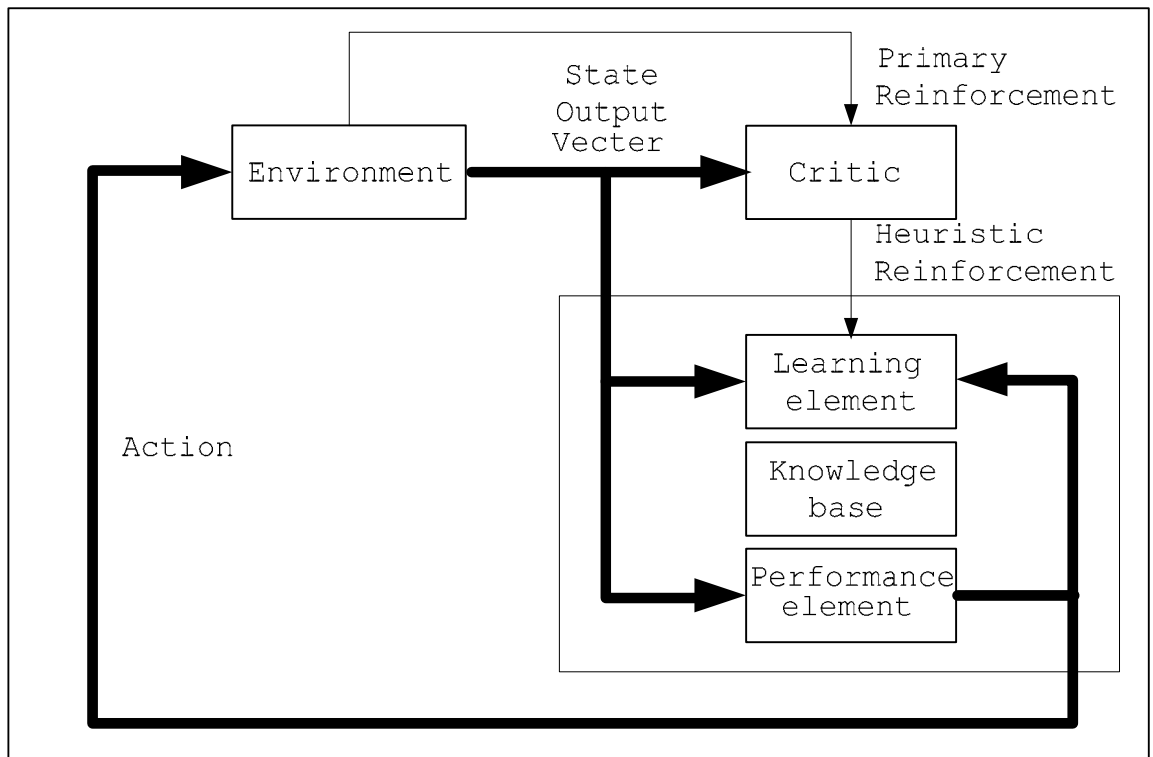

Figure 2-13 Reinforcement learning diagram

2.2.3 Neural Network Application

Neural network comes to apply with many side work group as example follows:

2.2.3.1 Recognition: The neural network as used to writing remembers is popular because of Neural network can remember the format that have the alternate chops to overlap. Type of neural network is multilayer perceptron.

2.2.3.2 Clustering: The principle works of this is property of input network similar. We assign in the same group neural network apply for this type is unsupervised learning such as ART Network and Kohonen's self-organizing feature map.

2.2.3.3 Classification: In case of adjust of learning and property of class will be input into network, Input of network will adjust into appropriate such as work at multilayer perceptron and linear Vector Quantization Network.

2.2.3.4 Forecasting: Type of supervised learning network is adjust from past data. Component of input and output object is at network of appropriate. This type networks apply from multilayer perceptron.

2.3 Irrigation efficiency

The efficiency of the irrigation is the data that shown the significant the work of the irrigations. Since designing and begin the project is know about the area around of cultivating area water requirement in irrigation area which will the one data that use to seek water requirement that a headwork and designing water-distribution canal specification and canal building. Irrigation Efficiency will form the cultivated area that can take irrigation water, when irrigation efficiency can seek from a book about general irrigation, in this study the irrigation will used definition.

Keadpitak said Irrigation efficiency mean the sum total of water quantity that the plant wants to follow the theory and water quantity that leak to seep in modify minus the rain use dividing by quantity the water distributed. (6)

Water quantity that the plant wants to use, water quantity for the preparation modifies, and water quantity that seep to appeared the earth is water quantity that want in modify to cultivate that can calculate by theories. Water irrigation quantity that might can distribute is water quantity that mouth of a lane canal, if the calculation seeks the efficiency is sub canal or might water quantity that the main canal distribute.

Irrigation efficiency in this study means the efficiency that the calculation from the project water distribution and have maintained to finish and can distribute reach to cultivate. Efficiency Irrigation project at Lum Pra Pleang Irrigation Project in the rainy season of year 1970 (66,800 farm areas) get 54 % values and the double-crop field year 1983 (20,000 farm areas) get 51% efficiency values. (7)

Efficiency Irrigation project at Nong wai, 2 L-RMC canal in practical season, the rainy season in year 1970 and 8,177 rai get only efficiency value 27.2%. (8)

Efficiency irrigation project at Sub Prado in the rainy season, year 1986, at 10,952 rais get 51% efficiency values. (9)

The meaning of the Irrigation Efficiency is the ratio that is linkage to the percentage between water net quantity to the farm used as algebraic equation; (10)

$$E_i = \frac{W_n}{W_g} \times 100$$

By E_i = Irrigation efficiency

W_n = Net water quantity delivered to farms

W_g = Gross water quantity before consumptive need

From W_n and W_g might tell the depth or the capacity.

Seeking efficiency irrigation formula for rice farm as follows (10)

$$E_a = \frac{ET + P}{W_p + R} \times 100$$

By E_a = Irrigation efficiency

ET = Using water quantity of rice

P = Percolate in the farm

R = Rainfall quantity

W_p = Water irrigation quantity that the cultivated area receives

Or E_a =

$$\frac{W_p + R - W_d}{W_p + P} \times 100$$

When W_d = Water distribute from rice field

The calculation seeks irrigation efficiency of many irrigation projects in Thailand for rice farm given by (10)

Irrigation Efficiency

$$= \frac{(\text{Crop water requirement by theory} + \text{Percolate} - \text{Effective Rainfall})}{\text{Irrigation water regulate}} \times 100$$

2.4 Crop water requirement by theories

2.4.1 Land Preparation

The purpose of the preparation state of soil that is appropriate for cultivating the period of the land preparation there is water alms. Most of transplanting rice seedlings depended on the moisture before the land preparation. Kind of soils will affect the percolate, evaporating in between the land preparation, and land preparation character such as land prepare modify for nursery or for paddy-sown water mire field. Because of the period of preparation become while use the water as aforementioned. Therefore the period of time in the preparation modifies is very significant. If period of preparation time is short, the water quantity that plan to need during the time will prepare to modify longer and affect designing water distribute system. For the rainy season if there is it rains in a period of time then the preparation will effect of land preparation.

Water quantity measurement used during land preparation to cultivate out-of-season dry season rice that the project of Nong Wai right side the area that study 200 rai, get the average about 412 a millimeter this values not add percolate. (7)

Water quantity measurement in sample farm at Ban Sara-Yok on 244 rai of the project Moon Bon in the rainy season June 1984 to September 1995, used the water in the land preparation to 223.50 a millimeter.(6)

2.4.2 Water quantity for Nursery

The water quantity for nursery means the water that is used for nursery plant lead the young plant growth. It is composted water quantity for the land preparation before rainfall and water quantity that preparation before cultivating.

2.4.3 Water Quantity for Crop Requirement

This quantity means water that rice requires during the progress with transpiration. It is included water quantity that evaporating from farm lands as rice uses, it depends on the temperature, sunshine, relative humidity, wind speed, the progress of the rice and rice seed. Using water quantity of rice can get both of the measurement directly from the calculation can as follows:

1. Using water quantity by the measurement directly can divide as follows:

- Lysimeter
- Study from soil moisture
- Study from sampling

2. Crops water requirement.

Crops water requirement could be calculated from the formula empirical. And calculating from the potential evapotranspiration. Mostly they used the Penman's method. (11)

The crops water requirement could be calculated as following:

$$ET_c = K_c \times ET_p$$

When ET_c = Water quantity for paddy fields

K_c = Crop coefficient

ET_p = Potential Evapotranspiration

2.4.4 Percolation

During cultivating, water will flow through the plant root passing the soil layers and down to the underground water. The transplanted rice seeding will participate water from the layer of the soil moisture. Leaking water rate way prepared the height of the water table.(6)

2.4.5 Effective rainfall

Effective rainfall means the rain quantity that can apply to replace the irrigation water that need to deliver to the plant or the rain that agree cage in modify the farm. It depended on rain quantity in each quantity using water time of the plant. The habitude of a farmer saving water farm and the height of the ridge the ability picks the water of in root plant. Topography character of the cultivated areas using water rate of the plant which grows and the way irrigation water distribute. (6)

2.5 Concept and theory of water management

2.5.1 The meaning of water management

Water management is an attempt to utilize water for plantation by using principles in management including operating monitoring, evaluating and analyzing the plan for the ultimate utility of the project. Under the objective of least cost, Avoiding conflict among water users and environmental impact. The essential components for water management are as follows:

- 1) Amount of reliable water supply
- 2) Water demand and duration water demand
- 3) Ability and efficiency of irrigation
- 4) People

Water management focuses on the fair and reliable water distribution all over the area, with the least cost, least problem most efficiency. (11) Described that the principles of water management should include 3 components:

1. Planning
 - 1.1) Irrigation planning
 - 1.2) Irrigation system maintenance planning
2. Operating
 - 2.1) Set up the conference to inform the objectives, plans, timing and limitations
 - 2.2) Assign function and responsibility to the officials. Setup the methods of coordinating and reporting
 - 2.3) Official training about the sequence, method and technique for operation and the problem solution
 - 2.4) Reporting the operation
3. Monitoring and evaluating
 - 3.1) Analyze to define the indicator for monitoring and evaluating to reach the aim
 - 3.2) Define the evaluating method
 - 3.3) Define the monitoring and evaluating schemes
 - 3.4) Define the analyzing scheme the further planning

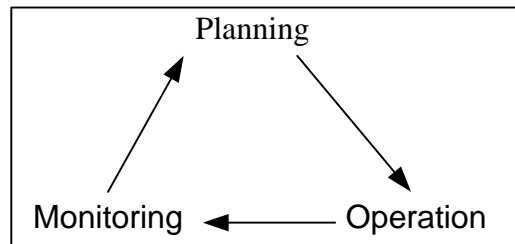

Figure 2-14 Water management diagram

Source: (9)

2.5.2 The irrigation project

The meaning of ‘irrigation’ constituted in the Statute of Citizen Irrigation in 1939 and the State of Government Irrigation in 1941 is a prefabricating plan to convey water from the sources or other subjects to utilize in irrigational activities and also protect damages on agricultural farm causal by the shortage of the water and on the water transportation within such irrigational areas.

2.5.2.1 The objectives of water management.

The objectives of water management in royal irrigation project are perceived: (9)

- 1) Reasons and necessity to water management
- 2) Irrigation water demand, irrigation planning and monitoring
- 3) Social problem, laws for water resource management measures and solution
- 4) Establishment and administration of irrigation user organization

Hence the water management in the irrigation project can be classified into 3 levels including water resource level, irrigation level and rice fields level.

2.5.2.2 Type of the irrigation project

The irrigation project can be categorized by the feature of projects into 3 types:

- 1) According to the objectives of benefit
 - 1.1 Profitable project
 - 1.2 Non-profitable project
- 2) According to the policy of each project

- 2.1 The project which relives distresses
- 2.2 The project which increases product
- 3) According to the size of the project
 - 3.1 Large irrigation project
 - 3.2 Medium irrigation project
 - 3.3 Small irrigation project

2.5.2.3 Structure and components of the irrigation project

The components of the irrigation project

(Boonyatarokul, 1983) include 5 parts as follows:

1) Water source: The irrigation project depends on the quantity and certainty of water from water source to supply to the cultivating area. Most are from rivers and natural streams.

2) Cultivating area: The region could obtain advantages from the irrigation project through water irrigation system from water sources throughout the whole area. The area in the royal irrigation project can be classified into 2 types;

2.1 Command area

2.2 Irrigable area

3) Headwork: Headwork is building constructed to block water in the stream for gathering the higher water level so that it can flow through canals easily.

4) Conveyance and Distribution system: The water way conveying water from water sources to agricultural area can be either streams or pipelines or both.

5) Drainage System: Drainage system is the waterway built to drain excess water from and irrigable area for the appropriate growing of plants.

2.6 Theories and Reservoir operation method Reservoir Operation study

The reservoir operation is water storage and supplying for various objectives with advanced planning in timing and quantity. It is operated with the planned process

whenever the condition in the future is like what was estimated. When the condition in the future differs from the estimate, the operation can be different from the plan. To reduce the water shortage, the objectives of the plan of a reservoir operation should be;

- To define the size of the most effective planting area without water shortage during planting season.

- To figure out of quantity of water to be irrigated each month

- To figure out the quantity of water to be stored each month

- To Figure out the quantity and period of overflow

- To figure out the critical period of water shortage (4)

Principle data for Reservoir management study should be:

1. Calculate finding irrigation need water and use for an algebraic equation water on demand should be:

$$IRR = (TR + P - ER) / IE$$

When IRR = Water distribution

TR = Water Quantity use by theory

P = Agriculture area percolate ratio

ER = Effective rainfall

IE = irrigation efficiency

2. Calculate finding retention quantity in an algebraic equation balance of model for reservoir follow as:

$$S_n = S_{n-1} + I_n - O_n - L_n$$

When S_n = Water retention quantity month (n)

S_{n-1} = Water retention quantity end month (n-1)

I_n = Inflow month (n)

O_n = Water distribution of month (n)

L_n = Water evaporation and percolation of month (n)

3. Water percolation in reservoir assumed 10% of water storage whole year could be calculated by equation as follow:

$$\text{Percolate ratio } i = ((S_i + S_{i-1}) * 0.1) / (2 * 365)$$

When S is water quantity day i and i -1 follow step.

4. Water evaporation and percolation quantity from reservoir
5. Relation of Volume-Elevation-Curve and Area-Elevation-Curve
6. Water quantity inflow per month from year of construct

calculate in 2 case follow:

Case 1 Compare Data of inflow and water storage by tank model

Case 2 Compare data of inflow and waters storage with Rainfall–runoff model, SCS then calculate to daily and sum total to month

Calculate water level change of reservoir from water data of irrigation on rain and dry season follow step 1 and inflow data follow step 6 and summary to monthly by year with reservoir operation study model finding of maximum benefit of water used and not patriotism water on rain and dry season.(10)

2.6.1 Water Quantity flow through the constructed regulation

As planning to irrigate the agriculture areas, the planners should have known the quantity of flow passing the water gate. They have to calculate the amount of flow correctly. The water gate may be operated by flow conditioning as free flow or submerged flow. The water gate regulation might be opened as part under or over the surface water. The characters of water gate building; some are constructed with water gate and some are not, are effective to the amount of water delivery.

As calculating, the engineers, they might be neglected some options off calculating parameters. The formula they used to calculate should have to investigate the co efficient for flow correlated to the size of water gate, water surface level, head and low water level. (7)

2.6.2 Inflow Quantity

Inflow quantity depends on many side factor together by can distribute 2 the group following at pertaining to the meteorology which there is the rain is an agent and pertaining to physical quality of basin of a river area.

The Side meteorology factor compose the intensity of the rain, the period of time that it rains, spreading out of the rain in the basin of a river, the direction of the area it rains, rain quantity that fall before that, the moisture of the earth, and meteorology in other state, such as temperature, wind, speed, relative, humidity. The factor of the character of basin of a river that area composes land used state, the size

and character of basin of a river area, topography state in the basin of a river, type of soils, and the factor is other such as the network of the basin of a river. (4)

2.6.3 Operation Rule Curve

The operation rule curve means how to operate the water storage from a reservoir for all objective by planning in advance that how much are should store and deliver the water in each the time. (12)

Reservoir administration was controlled by reservoir curve administration (Operation Rule Curve) monthly. Flowing lets off monthly minimum of the last stages of a current or tide. Reservoir administration of each basin will fix to go up in order to have letting off water enough quantity to the requirement. (4)

Operation rule curve

HEC-3 simulate model control input 4 water level.

1. Normal High Water; NHWL is capacity for dam to storage water.

2. Upper Rule Curve; URC is the curve to shows water storage in reservoir in that time. Use for prototype for reservoir management to control water distribution in level of URC. If upper level of the URC water distribution have more then normally time and enough for irrigation area. Then is water storage will have space for new water inflow and control URC again in case of water higher then upper rule curve and they need to distribute water to irrigation area by fully of spillway control.

3. Lower Rule Curve; LRC Normally means control lower level water storage in reservoir. Due to the problem of control for water deficient on dry season. So that it is preparing to control water storage

4. Minimum Water Level; MWL, The stability management of the reservoir if provide water distributing lower then effect to reservoir. (13)

2.7 Huai Jorakhe Mak Irrigation Project



Figure 2-15 Studies area map

Source : (14)

2.7.1 Huai Jorakhe Mak Irrigation Project

It is the irrigation project which was built to keep the water and protect the inundation Moung district Buriram province. It is located at Ban Huai pheung Tumbol Banbao Moung district, Buriram province. It is far from Buriram city 12.7 Km. by public road and separate from public road line Buriram-Prakonchai at Km. 10.

The location follows base map 5638 IV L7017, between Latitude 14° 53' 15'' Longitude 103° 00' 45'' and Latitude 14° 55' 00'' Longitude 103° 03' 30''. Construction in 1962 and finished in 1963. Administration depended on the irrigation project of Buriram province Irrigation Project.



Figure 2-16 Huai Jorakhe Mak Irrigation Project Map
Source: (15)



Figure 2-17 Huai Jorakhe Mak reservoir

2.7.2 Huai Jorake Mak reservoir area

The boundary takes rainfall	113.64 square kilometers
Storage area	7,900 rai
Max deep level	7.00 meter
Normal high water capacity	27,363,000 millions cubic meter
Dead storage	1.473 millions cubic meter
Rule curve storage area	5.50 square kilometers
Inflow average per year	33.84 millions cubic meters

2.7.3 Assume level comparison

Retention level	+ 162.50
Normal high water	+ 163.00
Dead storage	+ 159.00
Earth dam level	+ 163.50
Weir head level	+ 158.50
RMC threshold level	+ 159.00
LMC threshold level	+ 159.00
Emergency level	+ 162.00

(Comparison with sea level + 0.596)

2.7.4 Building component and Water building control

1) Earth dam type zoned fill in side made from fat clay distance 1.9 Km. High 8.50 meter weir head assume level 163.50 meter. Weir head wide 6 meter.

2) Spillway type ogee weir, weir head assume level 158.50 meter. Spillway ogee control water distribution 3 channel size 4.00 x 4.40 meter. Maximum provide water distribute 138.50 m³/sec and Emergency spillway seem long open 140 meter at assume level 162.50 meter maximum provide water distribution 100 m³/sec

3) Building component of main canal right side design for water delivery from earth dam for Tumbol Ban bua, Tumbol Samet of Amphoe mung Buriram province agriculture area. RMC drainage ditch size \emptyset 1.00 meter.

4) Building component of main canal left side design for water delivery from earth dam for Tumbol Ban bua, Tumbol Krasang of Amphoe mung Buriram province agriculture area. LMC drainage ditch size \emptyset 1.00 meter.

5) Secondary Canal 1R – LMC, 2R – LMC, 3R-LMC, 4R-LMC, 5R – LMC design to drainage ditch size \emptyset 0.60 meter.

2.7.5 CANAL

- 1) Main canal right side (RMC) 12.139 Km. (irrigation area 3,950 rai)
- 2) Main canal left side (LMC) 18.103 Km. (irrigation area 5,656 rai)
- 3) Secondary canal 1R - RMC 1.340 Km. (irrigation area 456 rai)
- 4) Secondary canal 2R - RMC 1.225 Km. (irrigation area 250 rai)
- 5) Secondary canal 3R – RMC 1.080 Km. (irrigation area 605 rai)
- 6) Secondary canal 4R – RMC 1.475 Km. (irrigation area 854 rai)
- 7) Secondary canal 5R – RMC 2.210 Km. (irrigation area 729 rai)

Summarize layout description shown following:

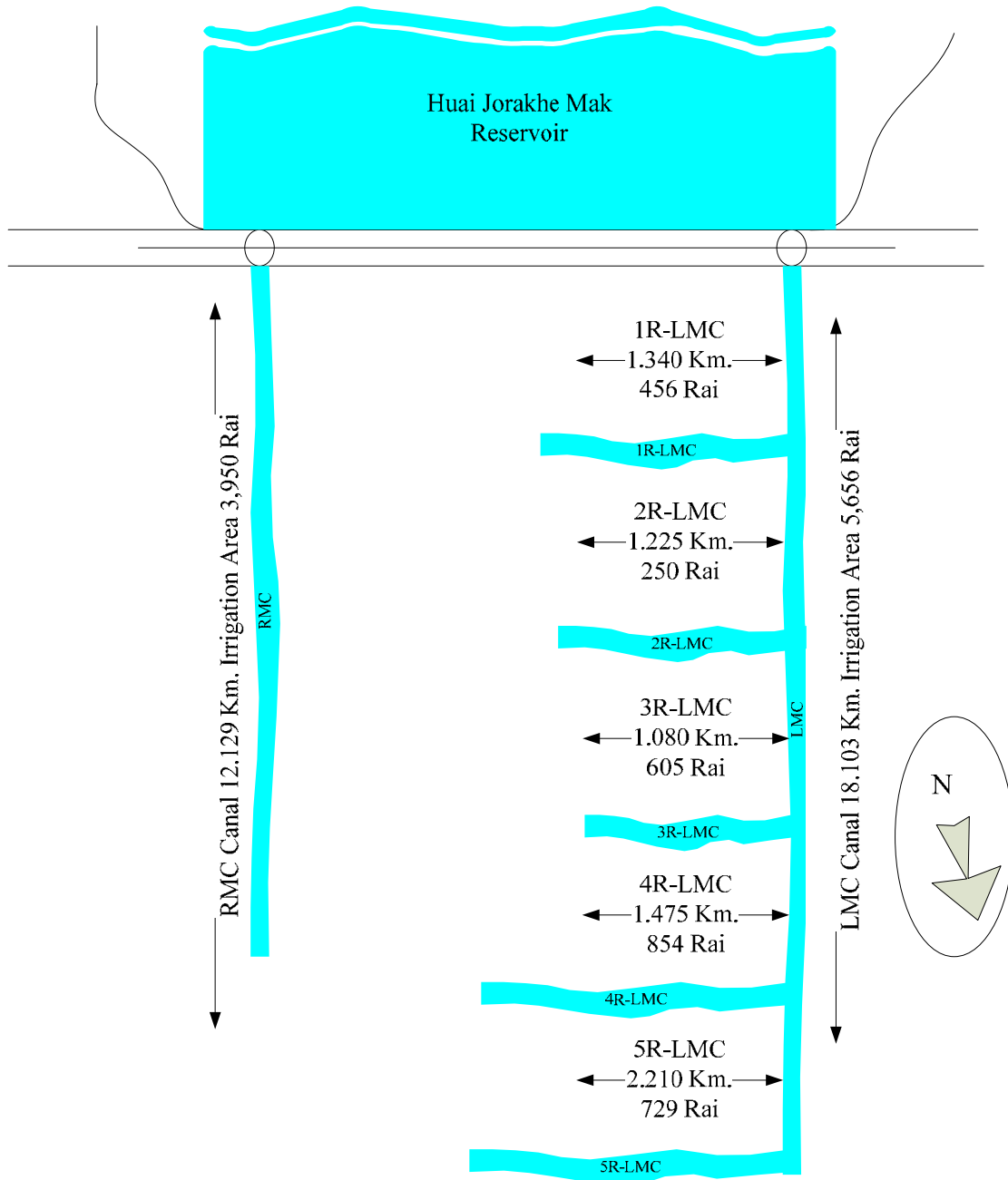

Figure 2-18 Huai Jorakhe Mak Reservoir layout canal

Source: (15)

Table 2.1 Building component of canal

Building type	Total building						
	RMC	LMC	R1- LMC	R2 - LMC	R3 - LMC	R4 - LMC	R5 - LMC
1. TURNOUT	27	23	5	4	4	6	7
2. ROADWAY CROSSOING	3	21	-	1	5	-	3
3. PIPE DROP	-	4	-	3	3	2	3
4. PIPE DROP WITH CHECK	2	-	-	-	-	4	5
5. DRAIN CULVERT	40	50	5	6	7	-	-
6. CHECK	7	6	-	-	-	-	-
7. LIVESTOCK CROSSING	3	7	-	-	-	-	-
8. BROAD CRESTED WEIR	1	1	1	1	1	1	1
9. SLAB BRIDGE	1	5	-	-	-	-	-
10. ROAD CULVERT WITHOUT CHECK	2	2	3	2	-	-	1
11. ROAD CULVERT WITH CHECK	2	5	-	-	-	-	-
12. OVER CHUTE	2	5	-	-	-	-	-
13. TALL REGULATOR	10	1	-	-	-	-	-
14. DITCH GROOVE	-	-	2	2	-	-	-
15. SIMPLE VERTICAL DROP	155	66	12	11	6	3	6

Source: (15)

2.7.6 Others data of irrigation project

1) Summary rainfall by month of year

Table 2-2 Summary rainfall per year

Year	mm	Year	mm	MM-YY	mm
08,12 2001	239	01,12 2002	1,188.3	01,12 2003	1,588.1
01,12 2004	1,270	01,12 2005	1,641.2	01,12 2006	1,043.5

Source (15)

3) Summary regulate reservoir quantity per month of year

Table 2-3 Summary water regulate per year

MM YY	Hour	Cubic Meter	MM YY	Hour	Cubic Meter
09,12 2001	2,523	4,402,129	01,12 2002	4,316.3	5,694,242
01,12 2003	5,477	6,568,787	01, 12 2004	5,805.3	5,993,060
01,12 2005	4,644	7,599,474	01,12 2006	3,632.0	2,564,223

Source (15)

2.7.7 Activities and some others benefits from reservoir.

- 1) For agriculture area 12,500 rai (canal system support 9,065 rai)
- 2) For water supply in Buriram province community approximately 7,000 cubic meter per day
- 3) For breeding fish of Buriram province fishery office
- 4) For consume and livestock demand
- 5) For winter bird visit and place for breeding for local bird and winter bird visit

2.8 Literature Review

2.8.1 Neural network for simulate underground water lever and water distribution.

From agriculture area in Ottawa City Canada, Input Data of model is dally rainfall quantity potential evapotranspiration rates underground water deep level. Data for simulate from 1991-1993 and data of water distribution from area 1991-1994. Benefit from this study can apply to management and control underground water system be efficient because of data is real-time system. Output of model simulate to test by root mean square errors between 64.5-161.1 mm and 46.6-139.2mm in order. Result shows ANNs can apply to engineering work be efficient. (16)

2.8.2 Pasak jolasid reservoir operation by artificial neural network technique application.

Forecasting by collect data from the basin of a river rang of time 1-7 day in future. ANN Model separate to rain season and dry season result of model in the vicinity in fact past by efficiency (EI). In learning supervise examine of result ANN model on rain season more then 90, 71 and 70 % and dry season more then 82,

94 and 81%. ANN can apply of Pasak jolasid reservoir operation water flood state. (17)

2.8.3 Analysis of potential water for utilization at Huai Jorakhe Mak, Moung district, Buriram province.

To Applying effective Rainfall model, Irrigation Demand Model, System simulation Model. Alternate with dry season in agriculture area follow water quantity in storage end of rain season. Input data of agriculture area in Huai Jorakhe Mak reservoir and hydrology data from years 1963 to 1999 totally 37 years. The result shows that Huai Jorakhe Mak reservoir project can provide water full area since no activity and agriculture in dry season. Insufficient water only 2 months per 2 years. Average water need 1.62 millions cubic meter per months.

In fact, water management in agricultural area on dry season will alternate by water storage and effect to deficient water or no deficient water for agriculture on dry season. The arithmetic equation of agriculture on dry season is DSAR ($Y = 141X + 1.33$) when Y equal to agriculture area on dry season and X equal to water quantity when end of rain season or last of November of year (million cubic meter)

At present the local water supply got authorize to use water for water supply to amphoe Moung and Buriram community, 400,000 millions cubic meter. Is not effect to agriculture because the agriculture is lower than average. In fact, the agricultural area dose not over 1,000 rai. The reservoir has the potential to deliver water to agricultural area of 9,000 rai of rainy season and 1,328 rai of dry season accordingly. However, the supportation depended on the water quantity storage at the last November each year. (18)

2.8.4 Forecast Stream flow Simulation radio at Prajinburi river

Neural network model type Back propagation forecast stream flow simulation radio at Prajinburi river develop by computer software package RSNET for forecast support. Input data for simulation perform the water quantity of Prajinburi station and rainfall quantity station, 20 years of data to process training feature separate 2 type for years 1974 - 1993. Year of process is 1994 - 1998 the result of computer program package RSNET can forecast stream flow simulator efficiently. (19)

CHAPTER III

MATERIALS AND METHODS

Developing program for transpiration forecasting need statistic data of rainfall regulate reservoir schedule to input data. The summary task in this research consist of teaching computer about learning and remembering by ANNs that make computer use the statistic and dynamic data for decision making. The result use in planning prototype process regulate reservoir. This research separate into 3 parts.

1. Studying of water management and collecting the presently situation, statistic data, the past related reservoir data.
2. Developing the program for regulate reservoir design and develop following SDLC (System Development Life Cycle) process and applying ANNs theory into extension.
3. Evaluation System

3.1 Researching Steps and Determine

The sample group for design database and data structure following the system developing life circle (SDLC) as:

- 1) Sample Group
 - Rainfall data
 - Crop requirement for Irrigated
 - Water regulate reservoir
- 2) Stage of the Process
 - Checking information
 - Collecting data
 - Designing and developing system
 - System evaluation and Publish the system introduction

3.2 Studying presently situation and data Source

The water balance of Huai Jorakhe Mak reservoir were collect data from the record at daily, weekly, monthly and yearly. The data were used as input data into the system. The program will learn about the rainfall and water situation each day. For ANNs theory they will learn from the past and determine the future.

In this study, the reservoir data can separate fundamental as 5 groups.

1. The physical characteristic, the water surface level-the reservoir capacity through studying project's structure (architecture) and geography map
2. Long term rainfall data (daily data) from weather station
3. The inflow water quantity's data from water source, creek of irrigated area
4. The daily water level of the reservoir data and crop water requirement
5. Other data such as the length of canal and the capacity of main canal

3.3 Materials

1. Hardware

- PC Server PT 4 1.8 GB Ram 512 HD 40GB (Server)
- Laptop Intel Duo Core 1.8 (Clients)
- Personal Computer PIII (Workstation)
- Communication Network (Hub)
- Communication Network Cable

2. Software

- OS Linux Redhat V.9
- Mysql, OpenSource, Database
- PHP, Perl, Mysql_mod Build on Apache Web server
- C, Gcc, Compiler
- AppGINI Tools for database design
- Mysql front for database clients

3.4 System Develop

This research use laptop as a tool for developing program which installing Windows XP and Secure Shell Terminal to Remote control into coding server through FTP (File Transfer Protocol) and unix editor.

The program developing by C and PHP language on unix operator system that use Linux software and MySQL database installing into server which user interface through web browser. The connection, the users requests, the reports, the simulator base on web browser. The general methodology in development of information management system for water resource management of Huai Jorakhe Mak Reservoir shown as figure 3.1

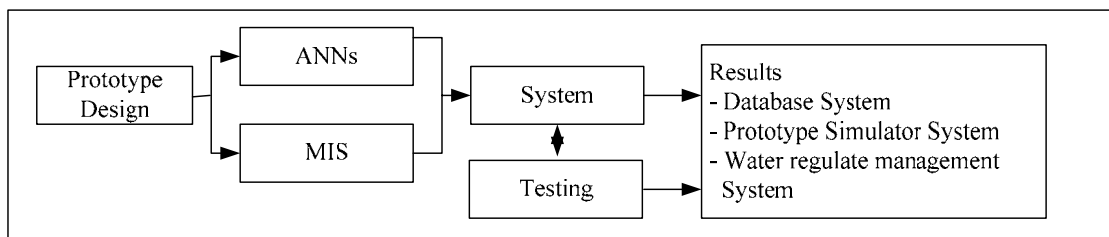

Figure 3-1 General methodology in development

3.5 Evaluation system

Installation the developed information system for user testing for a while to evaluate the satisfaction. The researcher determine the target group to evaluate in 3 users level.

- 1) The administrator level of system through their responses in questionnaires and satisfaction forms after testing.
- 2) The users of management level.
- 3) The input data user level.

Taking answers in each questionnaire to change into marks which separated into 4 levels of excellent= 4 points, good= 3 points, Fair= 2 points and needed improvement= 1 point.

Setting up hypothesis with statistically 4 points and interval scale per class 0.77 and testing findings probability of opinion through the developed Information Systems by divided into group.

CHAPTER IV

RESULTS AND DISCUSSION

Information Management System for water management of Huai Jorakhe Mak Reservoir' referral based on System Development Life Cycle (SDLC). The procedures of this research are as following:

- The result of information and technology requirement
- Problem recognition
- The solution
- The result of collecting the necessary data into system
- Design and construction the database
- The result of the system design and implementation
- Evaluate the information technology system by engineer staffs, officer and input data officer of Huai Jorakhe Mak Irrigation Project
- Re-improvement the system to be corrected and followed the user recommendation
- Publish the system introduction
- The result of statistics
- The commendation of this study
- The conclusion

4.1 The result of information and technology requirement

The information system, It could be divided to 3 parts as follows.

4.1.1 The information and technology require to presents the fundamental data of Huai Jorakhe Mak Reservoir in study area. Checking the related data, collected data, database management, design and develop the information technology and general data study area as spatial data references to chapter II at paragraph 2.7.

4.1.2 The information technology requirement presents ideas and ways suitable for evaluating. The information technology can show the ways to collect data and leading to evaluation procedure and, moreover, the future feedback.

4.1.3 The information technology requires collecting data, analyze and evaluate. The related data are collected and used for evaluation to searching information support data daily, weekly, monthly, yearly, and then results will be shown and easy to understand which it very useful the referral system planning management.

4.2 Problem recognition

The problem was found that the operating system decided by the staff to regulate the input crop water requirement and using the Microsoft Excel format to be a tool daily. By this way they had the problems as following:

- 1) There are not associated between file to file, so it is difficult to see the data as the integration.
- 2) It has used two process input data: writing by hand into the paper, and typing that figure into Excel, it probably has some problem occurred.
- 3) The decision processing would be delayed because too many staffs who take responsibilities and data collection from database sheet delayed.

4.3 The solution

Summary and analyze problems to get the best ways out and to block the future problem. To solve these problem, it is necessary to use data collected can be used for referral system planning. It needs to reread documents and inquiry question to set the problem indexes for the referral system. The appropriate model to support those problems is using the simulator of ANNs model. It should not be searching information about other recorded data. , But the corrected information should be a component also.

4.4 The result of collecting the necessary data into system

According to present system and collecting data from Huai Jorakhe Mak reservoir, we can divided the data into

- 1) Daily rainfall quantity since 2000 – 2005 A.D
- 2) Table of water regulate since 2000 – 2006 A.D
- 3) Daily water level since 2000 – 2006 A.D
- 4) Water assumed level
- 5) Water supply at local
- 6) Reservoir area based data
- 7) Crop water requirement

The above data will be used in analysis and design process which will be collected in attaching CDROM.

4.5 Design and construction the database

The researcher divided data into 7 tables. From analyzing and the user requirement data, the construction of the real database was using DBMS, which are tables and either relation or from summarization of table or data dictionary are showing on appendix A.

4.6 The result of the system design and implementation

The result of the system design and implementation as followed:

- Study the appropriation of the developing system.
- Process design, starting from context diagram to show the overall system then use the data flow diagram to show the input-output data at each specific process.
- Creating web pages for user interface.
- Drawing out the structure chart.

- Writing the program from the logical data flow diagram by using the specific program supporting the developing information technology.

4.6.1 Technical Feasibility

This is to study about the feasibility to construct the new system by using the existing technology. In construction the new information system, It need to use the computer that compiled push efficiency to identical need of users, the researcher set the spec of hardware and software as showing in pattern below.

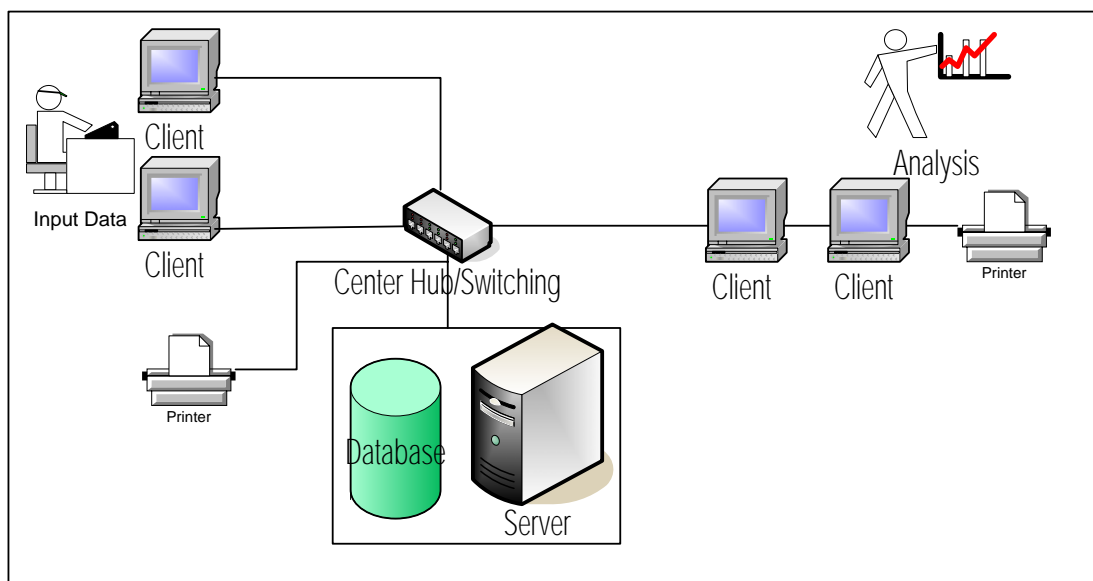

Figure 4.1 User Requirements (Hardware Feasibility)

The descriptions from figure are conversed.

- Server CPU 1.8GB RAM 256 HD 60 GB
- Communication hub
- Communication cable
- Local area printers
- Clients workstation (depend on officer computer)

4.6.2 Operational Feasibility

This step is the studying about the feasibility of the new system to accurate and correct to the user requirement, including the amount and skill of personal. This system can classify the user into 2 types and access program as following:

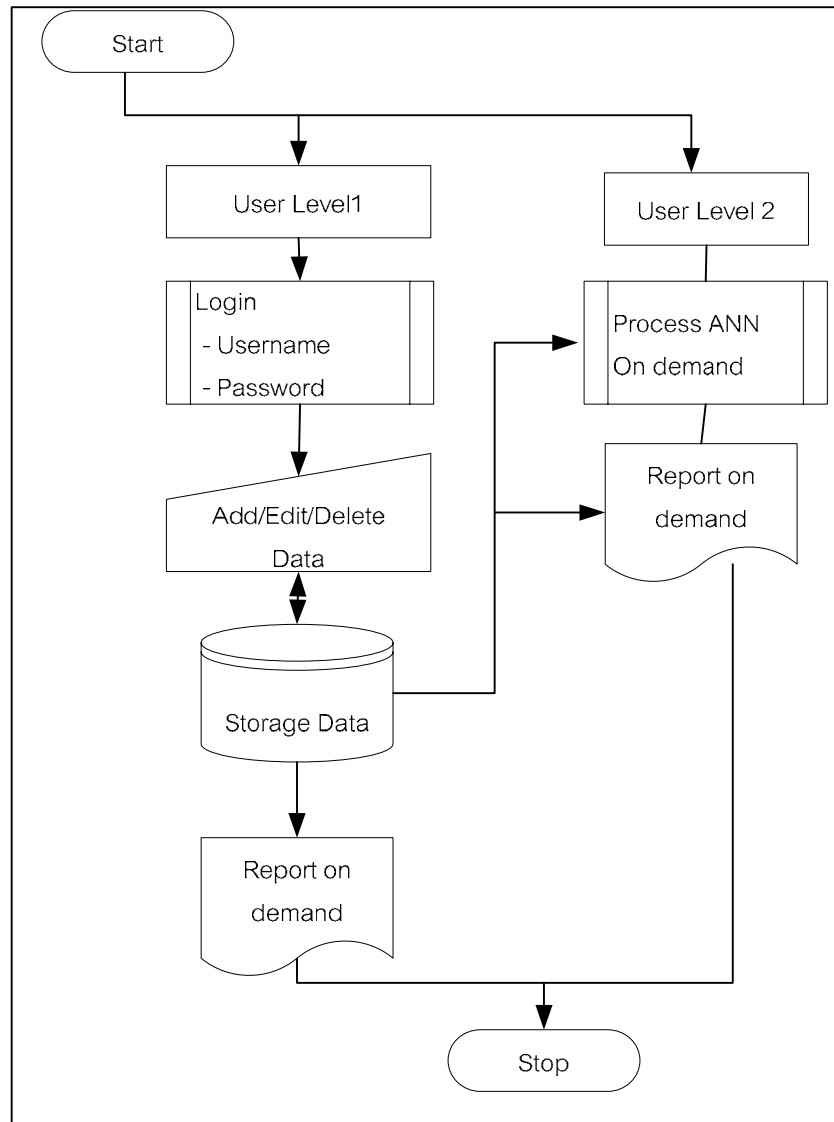

Figure 4.2 User requirements (Software Feasibility)

The descriptions from figure are as followed:

- Server Unix Linux Redhat DBMS Mysql Apache Web Server, PHP

- Clients Workstation depend on personal computer of officer

Types of users

- The general user means the person who can access to the program from only read or look general data in the database and simulate finding out put from model forecasting water regulate reservoir.

- The privilege user means the person who have special obligation to access the program and selecting, recording, and updating the data in database and should to using username and password for login.

4.6.3 Process design

The process design is need for showing over all of system (show as figure 4-3) that is composed the Work Flow Diagram from the analysis and context diagram (show as figure 4.4-4.8)

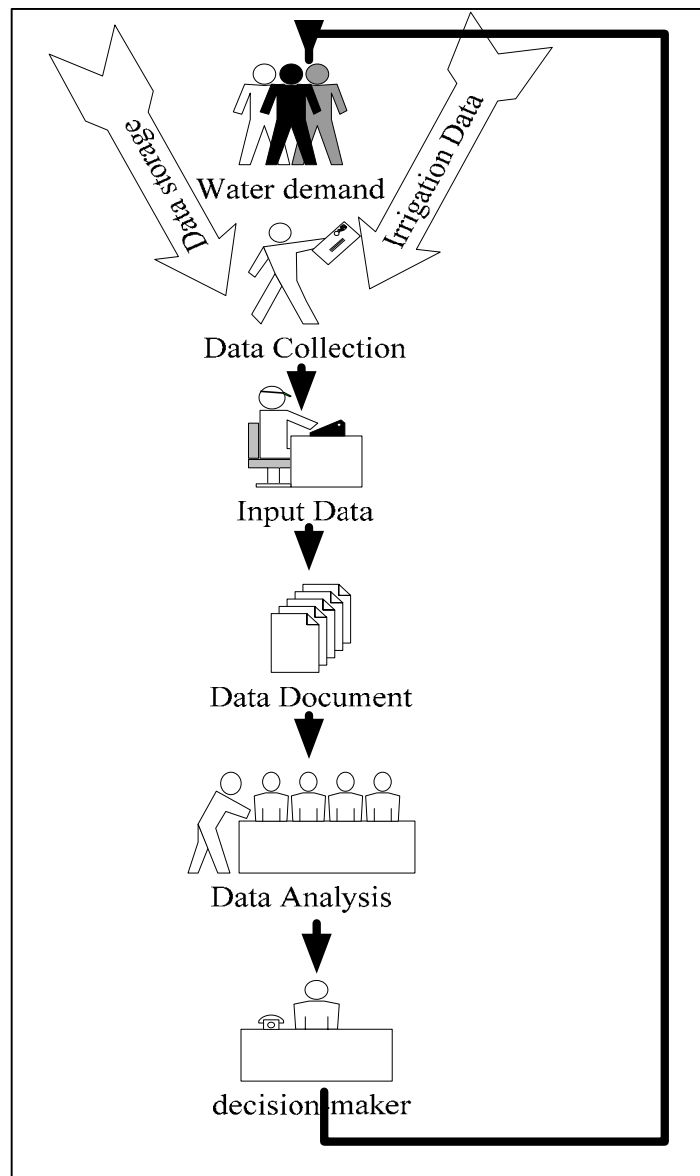

Figure 4.3 Work Flow Diagram from system analysis

Analysis work flow diagram and applying the data into flow diagram model and context diagram model of develop the logical are showing as stage following:

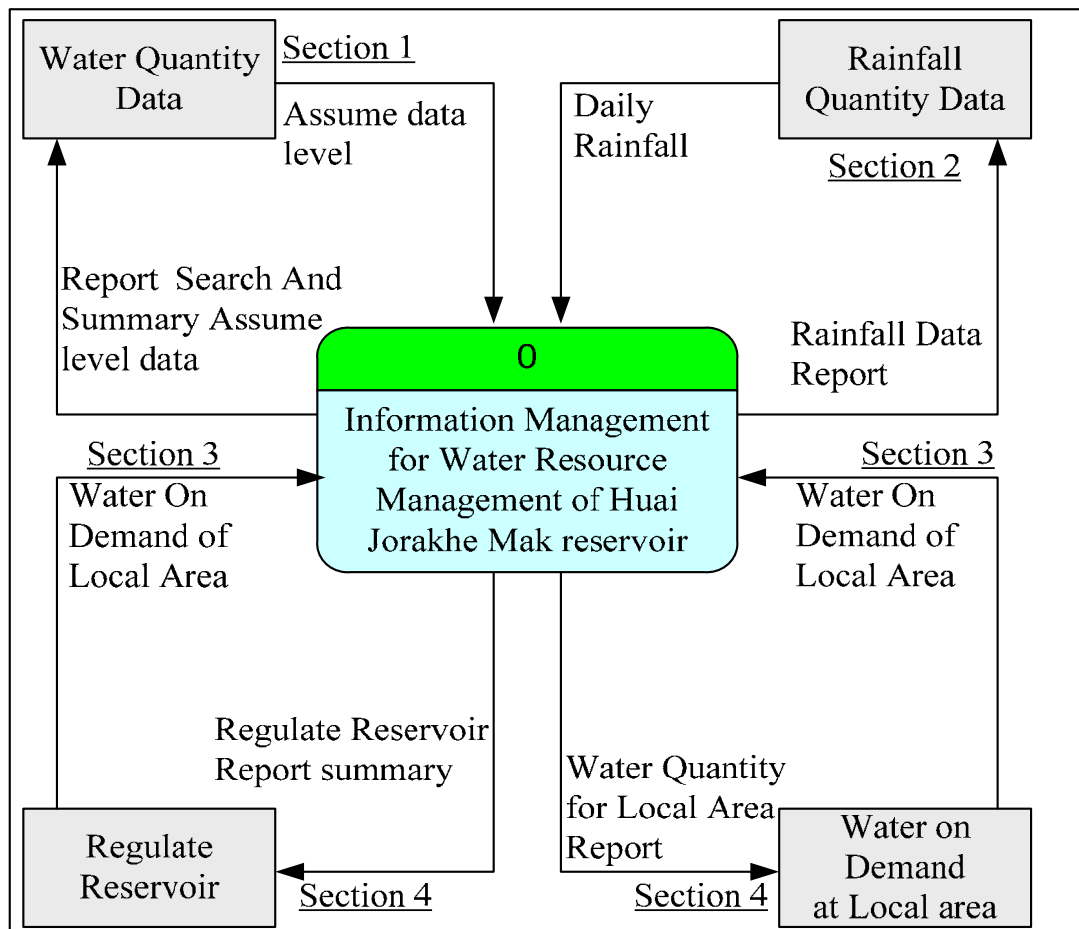

Figure 4.4 Context Diagram 0 of flow data

Context of data flow diagram are divided into 4 sections as following:
 (Figure 4.3- Figure 4.6)

- Section 1 Water level in the reservoir
- Section 2 Rainfall quantity
- Section 3 Water demand
- Section 4 Modeling of regulate reservoir

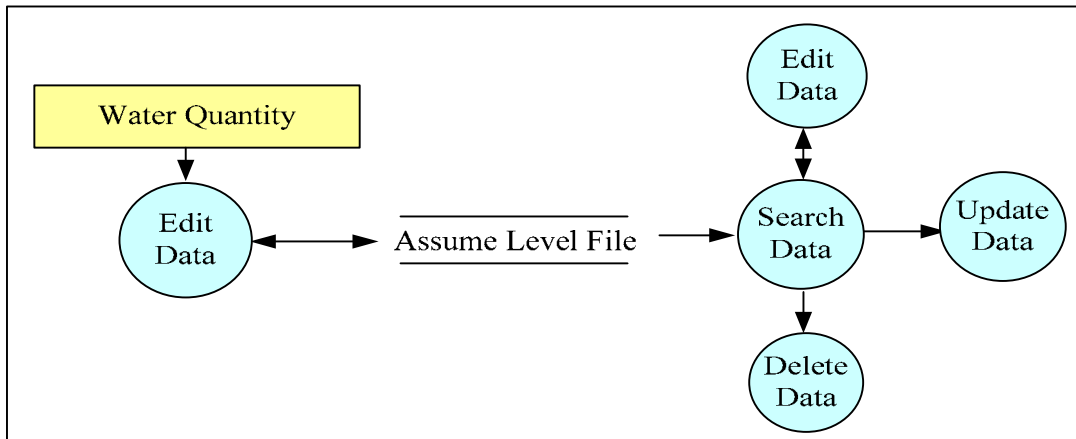

Figure 4.5 Data Flow Diagram of the 1st Section

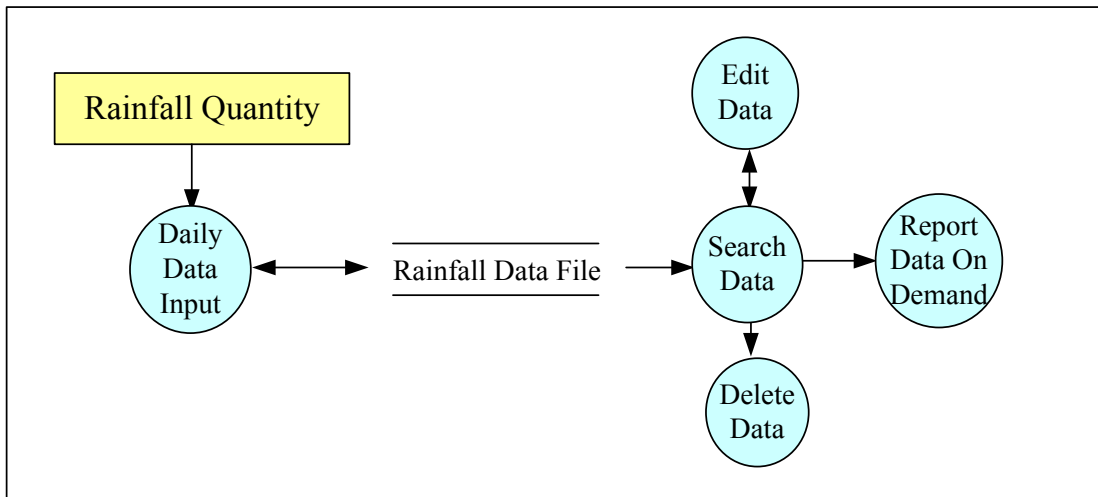

Figure 4.6 Data Flow Diagram of the 2nd Section

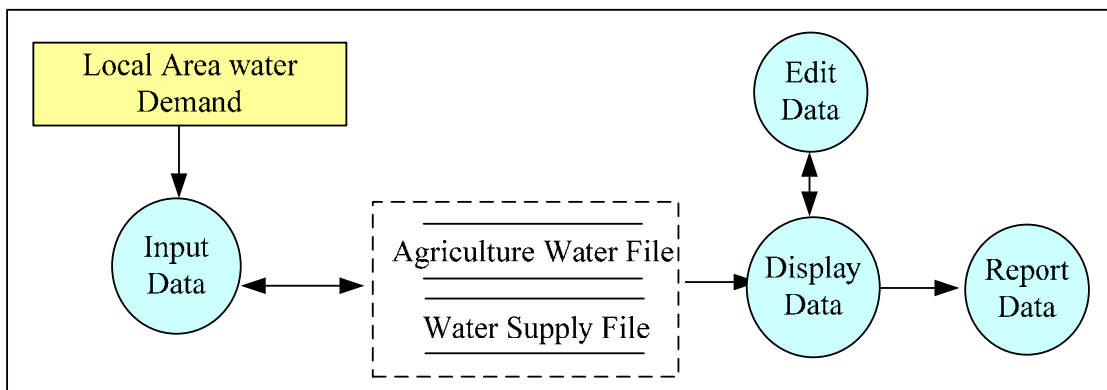

Figure 4.7 Data Flow Diagram of the 3rd Section

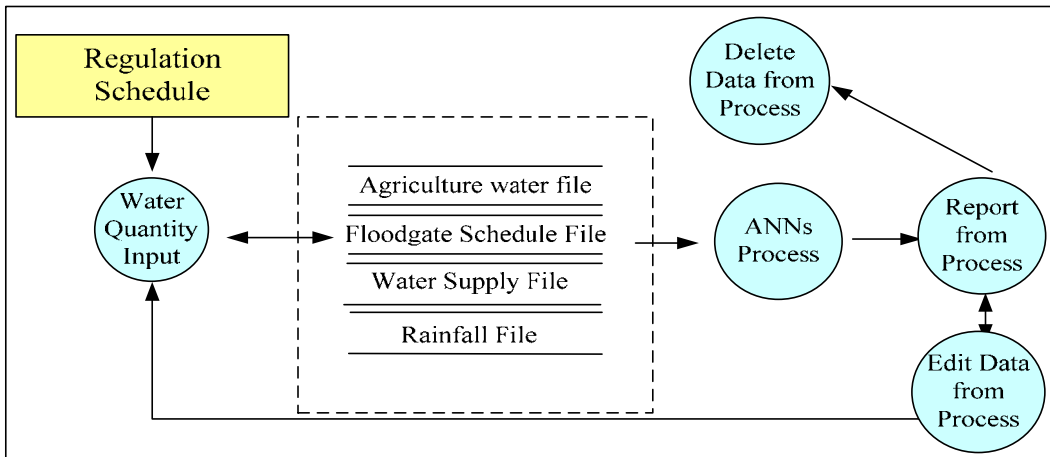

Figure 4.8 Data Flow Diagram of the 4th Section

4.6.4 System development reference to neural network

The system has developed by PHP language and Mysql database. The result of the structural database design will be shown at Appendix A.

The Neural Network analysis was the system that the researcher to develop in the regulation of the reservoir operation system. This operating system tried to control the water requirement at daily, monthly, and yearly corresponding to the water storage automatically. The regulation operating system could be concluded as figure 4.9.

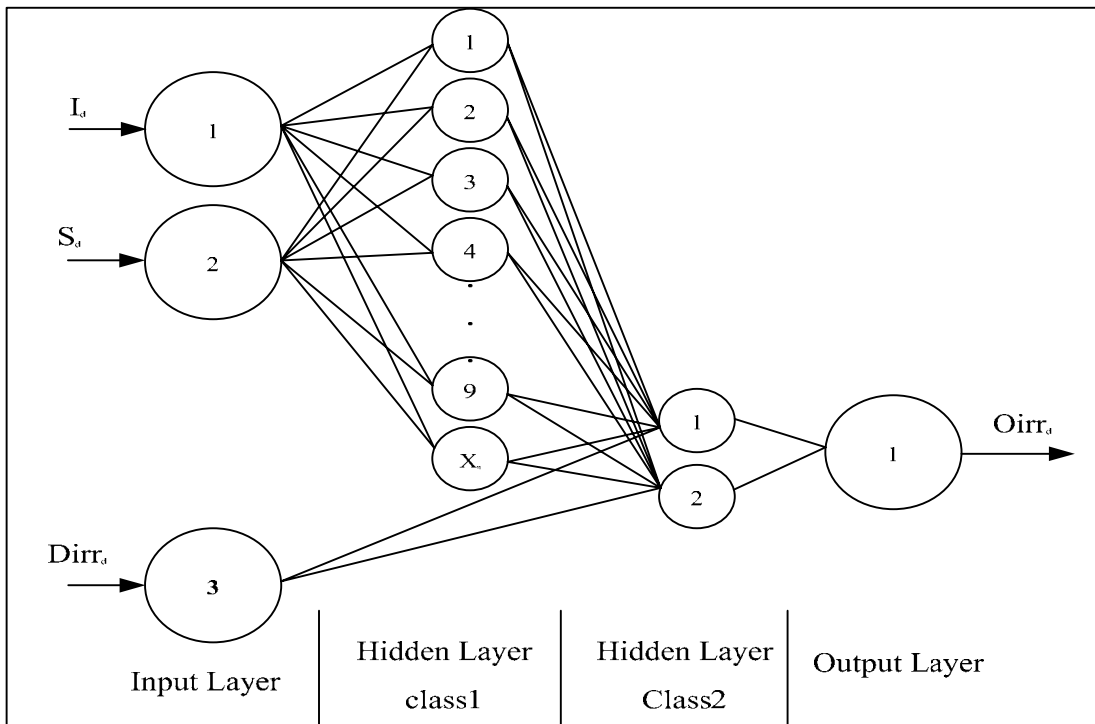

Figure 4.9 Neural network diagram for developed design

From Figure 4.9 descriptions are shows

By	I_d	=	Daily rainfall
	S_d	=	water quantity supplies at daily regulation
	D_{irr_d}	=	water requirement in irrigation area
	O_{irr_d}	=	water quantity per day to regulate
	d	=	date d

1) I_d is daily rain recorded from Huai Jorakhe Mak reservoir during 2000-2005 A.D. The simulator program can process when user input rainfall data for predicting future of a year by processing some hidden process. It was learning data from the past to predicting future. If user does not input data of the year to simulate, a system will learn only data from the past.

2) S_d is daily and time schedule for regulate reservoir.

3) D_{irr_d} is data of water demand in irrigation area. The data will store at master file in logical program. The program will take that data to process and kept as a hidden layer class 1 and logically took data to compare the maximum and minimum from hidden layer 1 and then provided how much water quantity to regulate from reservoir.

4) O_{irr_d} is water quantity provide per day and time from system processing.

5) Hidden layer 1 and 2 are the hidden layer to compare data and average sum or others by logic of neural network and process from input layer. They are processed at a hidden layer and sent output from hidden layer by logically of neural network type to feed forward.

The hidden layer learns to recode (or to provide a representation) for the inputs, more than one hidden layer.

The program will take higher efficiency result if the hidden layer 1 and 2 were used then the only one single-layer. This units are little more complex then those the original feed forward and resulted only small error in the system (input/output).

Output of data simulator time table to regulate reservoir and detail of data simulator include output simulator (O_{irr_d}) program are shown at appendix D pages 81.

4.6.5 User interface design

In this step, the researcher designed the interface linkage for connecting to the program comfortable and attractive to use. Standard of user interface design shown as follow figure 4.10 to 4.13

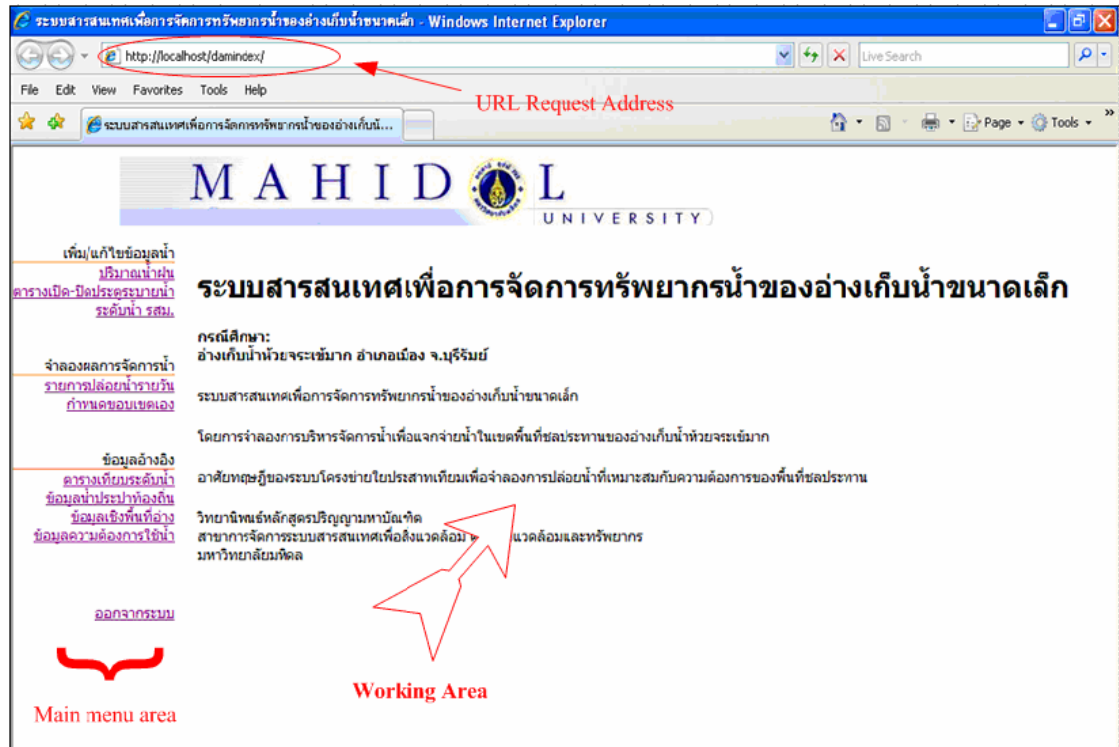

Figure 4.10 User interface design

1. Level of user

- General user can access the system for only read or see general data, model simulator and report on demand.

- Privilege user can access all of the part of the system by fully functions.

2. The system access

The user is filtered by level to access to the system by general user who can access to the system immediately by click main menu area. Some of menu cannot use due to the system is protected from safety. The powerful web based manager of management system. It gives you easy management and control over all the restricted on your web site, permissions for your site. Try it and see how level to access.

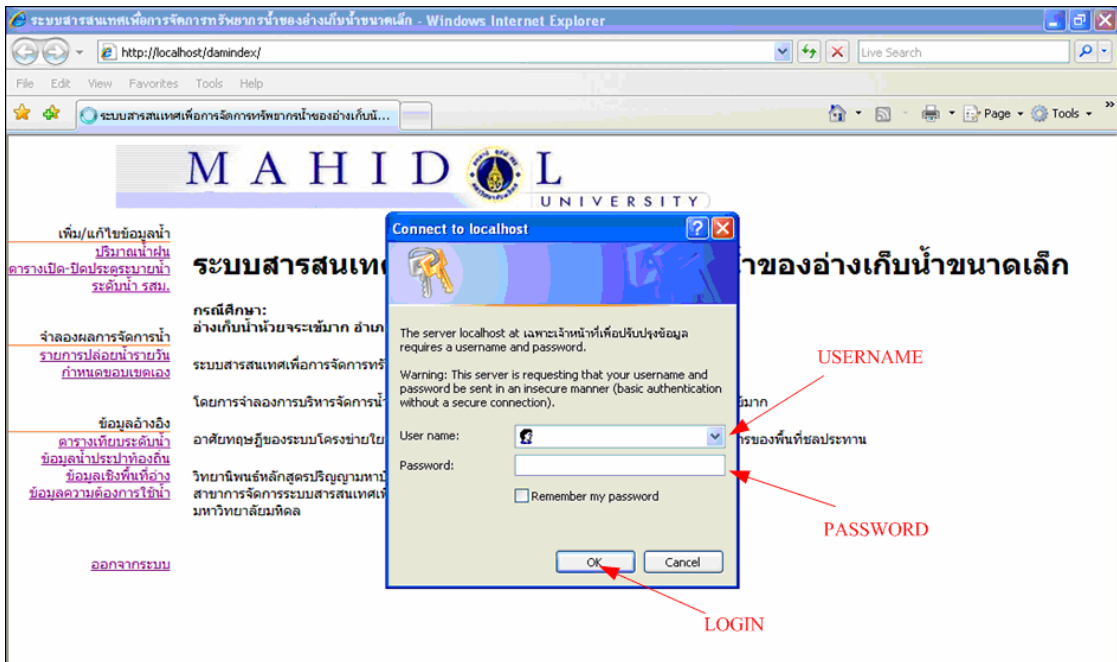

Figure 4-11 Username and Password request form

The privilege user can access to the system by input username and password for the logging into the system. After pass of password checked all of system menu can use ordinarily

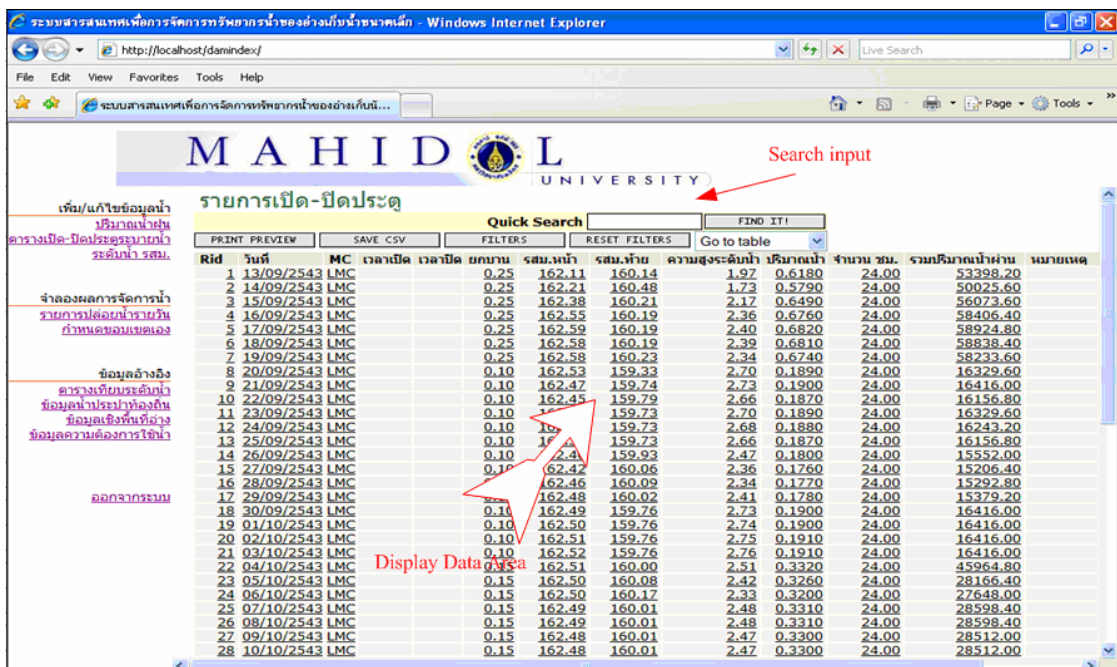

Figure 4-12 Standard screen output display

The pages used form developed is starting display. On left hand side of monitor is display menu and right hand side is data recorded shown. From data record

showing, the user can click to access data of current data to display on standard screen shown at figure 4.13.

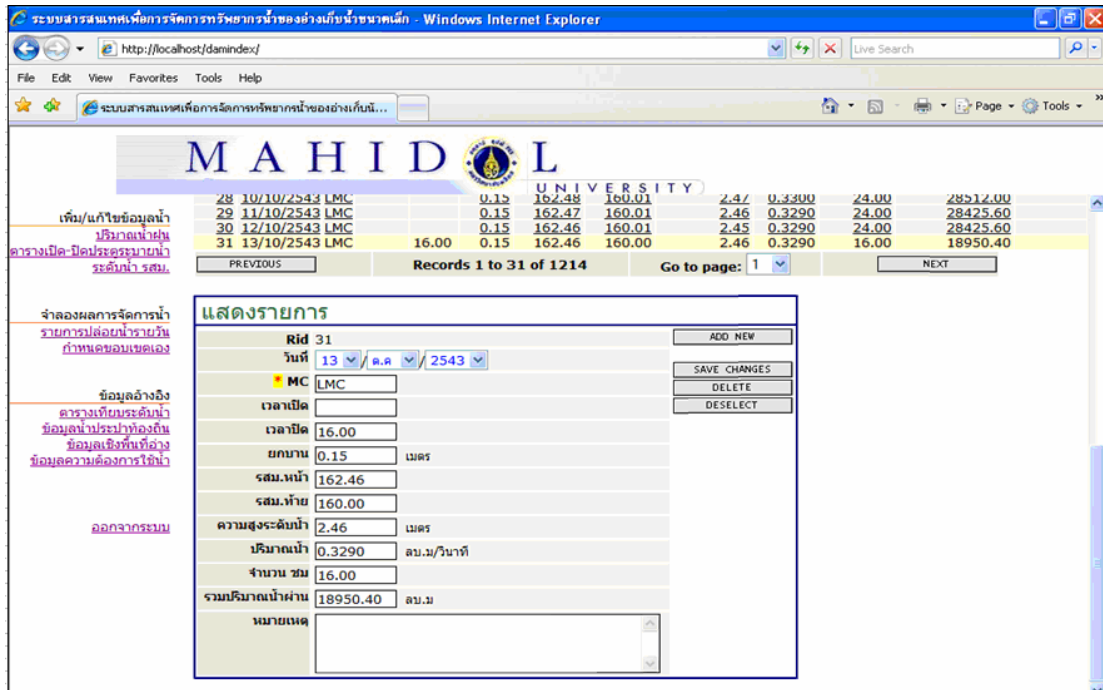

Figure 4-13 Standard input screen and current record display

Record selected will display at this box of a description current data record. By this record, the user form design is easily to use by user. The description of bottom of page shown as following:

- **ADD NEW** is bottom for add new data, after input data on user want to input all of field into text box and click add new for add data into database.

- **SAVE CHANGE** is bottom for save data from update or edit. Before use this bottom, the users have to fine out data or record to edit and click that record on search page then data will show at text box after edit data then click save change to store data into database.

- **DELETE** is bottom to delete data at current record data from delete cant recovery by database concept.

- **DESELECT** is bottom for cancel current data record on display in text box.

- **Display Data** is the area space on screen to display data, by this area, the users can click mount to any record on screen then data will display show at figure 4.13

- **Print Preview** is screen to display data on screen
- **SAVE CSV** is bottom for save data into CSV format in EXCEL.
- **FILTERS** is bottom to access into filters values for search data.
- **Reset Filters** is bottom to reset filters data value for search.
- **Quick Search** this bottom can click after input data on demand of user. Then system can find out data all of word like user typed into text box.

4.7 Evaluate the information technology system

The Buriram irrigation project officers or engineers of Huai Jorakhe Mak reservoir have asked to answer questionnaires (Appendix B); how satisfied they are for testing the simulation model. The satisfaction form were shown the values which were varied from 1-11 (Appendix C)

4.8. Re-improvement the system to be corrected and followed the user recommendation

4.8.1 System Testing

The result from the system testing could be divided into 4 levels as follows:

1. Database system testing: The research has tested the system performance and accurately. After the system has been tested each parts of program by the sample data, the accuracy of programming and the result from each part were corrected and satisfied.

2. Sub-function of program testing: Test of the data linked between each part of subsystem and the result from each subsystem were satisfied.

3. System testing: The author had verified all operations of the system to find out the problems and all of errors. Then it was improved until the complete system could be used for solving the problem of users required to the accurate, rapid and efficient performance in practice.

4. Simulator testing: The test comparison output from simulator program with old data from the years of recommendation. The results of simulate testing was shown as figure 4.14 – 4.17.

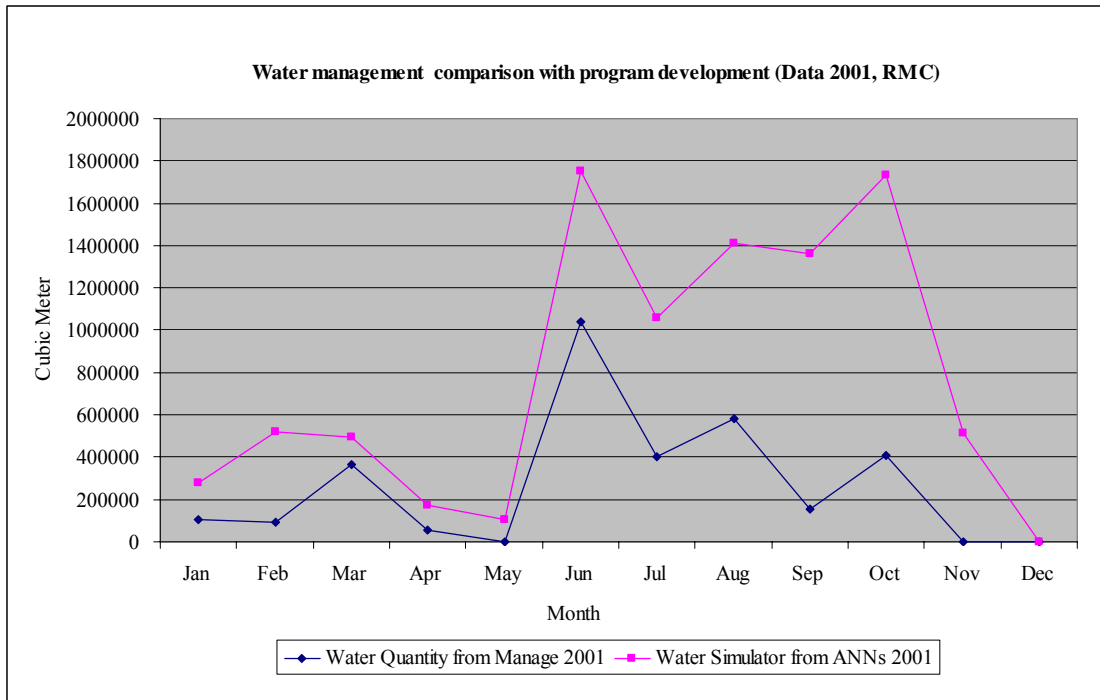

Figure 4.14 Compared results from data simulated model and actual data year 2001 (RMC)

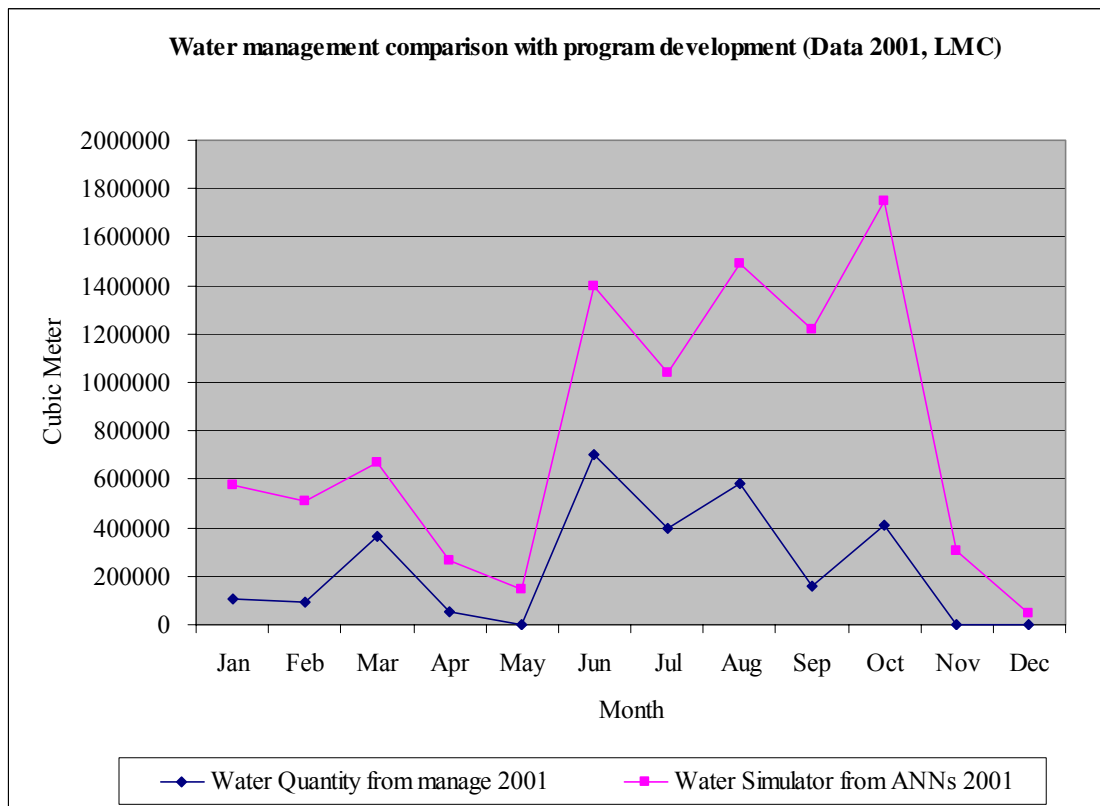

Figure 4.15 Compared results from data simulated model and actual data year 2001 (LMC)

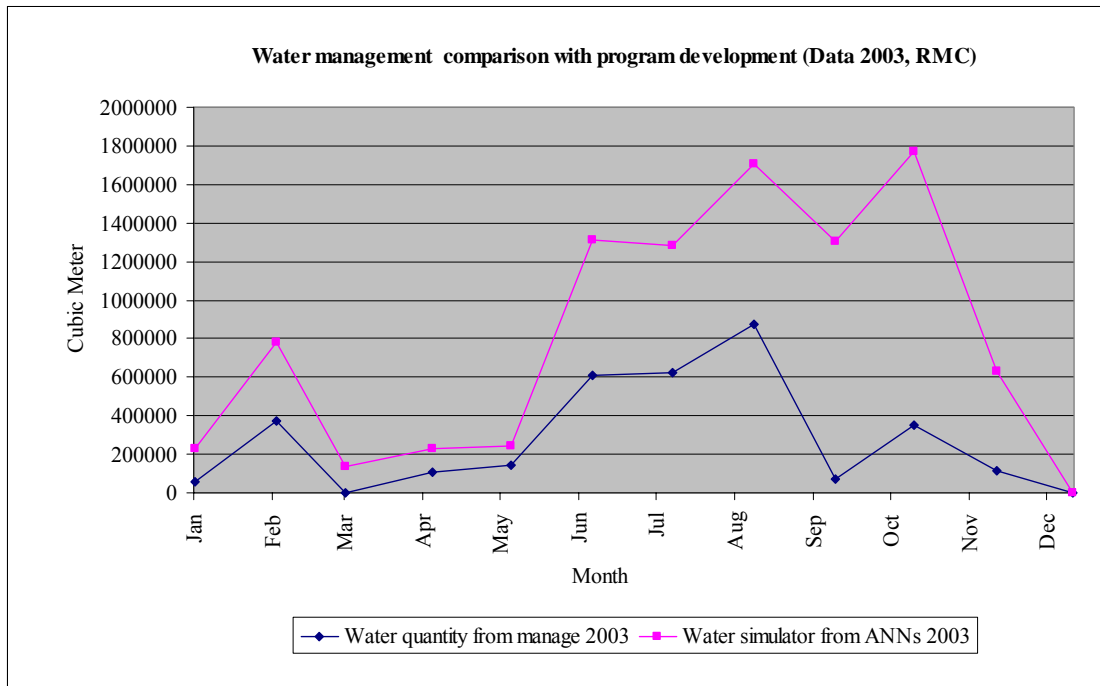

Figure 4.16 Compared results from data simulated model and actual data year 2003 (RMC)

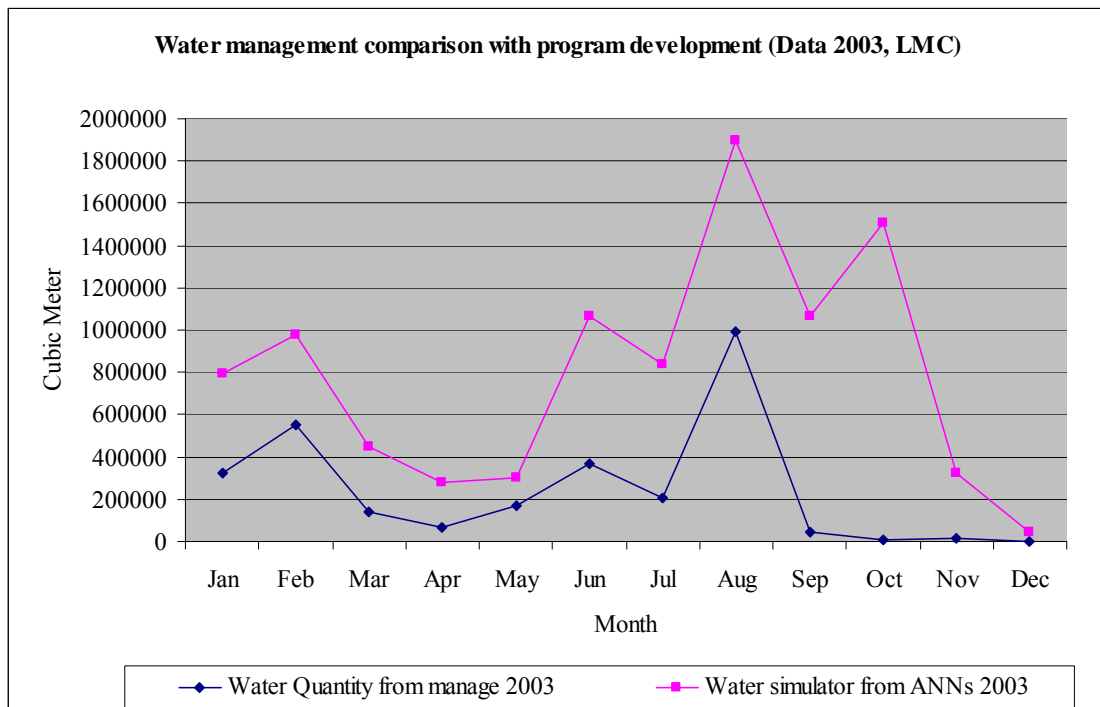

Figure 4.17 Compared results from data simulated model and actual data year 2003 (LMC)

In application, where the goal is to create a system that generalises well in unseen examples, the problem of overtraining has emerged. This arised in over complex or over specified systems when the capacity of the network significantly exceed the needed free parameters. There are two schools of thought for avoiding this problem: The first is to use cross-validation and similar techniques to check for the presence of overtraining and optimally select hyper parameters such as to minimise the generalization error. The second is to use some form of regularization. This is a concept that emerges naturally in a probabilistic (Bayesian) framework, where the regularization can be performed by putting a larger prior probability over simpler models; but also in statistical learning theory, where the goal is to minimise over two quantities: the 'empirical risk' and the 'structural risk', which roughly correspond to the error over the training set and the predicted error in unseen data due to over fitting.

As evaluating the results, the value of the simulated coming could be displayed to compare with the actually practice. There will be difference output from the simulated program and the actual practice in the rainy season. The graphic results are different due to:

- 1) The case of heavy rain in rainy season and the reservoir was still keep water and then liberating the large amount.

- 2) The researcher did not use the effective rainfall in pertaining the developed program.

This reasons (1 and 2) might caused the difference of the water calculation between the simulating program and the actual practice. However, the water regulation and the trend of graph plotting were shown consequently the same direction.

4.9 Publish the system introduction

The manual use of the program of the Information Management System for water resource management of Huai Jorakhe Mak reservoir were shown the detail in appendix D.

4.10 The program satisfying test

4.10.1 The program has been installed at Huai Jorakhe Mak irrigation office. The program were used by the officers as keying the blind data or setting up the actual data to get to report results of the simulating program and the actual practice duplicationly.

The questionnaires were conducted as material used to find the system satisfaction.

The questionnaires of 7 parts were showing on appendix B.

The officers, who working at Huai Jorakhe Mak Irrigation Project, 7 persons were asked to fulfill the questionnaires. They were on the position as following:

- 1) The administrative or decision making level 2 peoples
- 2) The practically Level 4 peoples
- 3) The input data level 1 people

The satisfaction assessment from system information development for water resource administration of Huai Jorakhe Mak reservoirs, can summarize and showing in table of Appendix C

4.10.2 The answers in each question had changed into scoring which separated into 4 levels. The Interval measurement scales, one unit on the scale represents at 0.77 and rank scoring shown as table 4.1.

Table 4.1 System evaluate rank point

Satisfaction Level	Rank of point
(4) Excellent	$3.29 < \bar{X} \leq 4.00$
(3) Good	$2.53 \leq \bar{X} \leq 3.29$
(2) Fair	$1.76 \leq \bar{X} < 2.53$
(1) Poor	$1.00 \leq \bar{X} < 1.76$

4.10.3 The results had shown that they are satisfied the program and given 2.92 of total scoring.

4.11 The commendation

4.11.1 The recommendation of system.

1. The information system as actual implemented, there should be increased more operational functions for support actual operation.

2. The researcher was felt that he had less supportation neither data nor time.

3. A technician officers need more training about unix operation system for maintaining the server and database system in the fields of Linux Redhat to operator system of unix.

4. The engineers and staffs need training the operation.

4.11.2 The commendation of engineers and officer staffs

1. The engineer and office staffs need to training the program on using web base interface such as Explorer, Mozillar Firefox, Netscape.

2. Data input should be verified and updated.

4.12 The conclusion

4.12.1 The information Management System of water resource management of Huai Jorakhe Mak reservoir system had been indicated 2.92 scoring by 4.0 totally. It was regimed in good level as evaluated by the officers.

4.12.2 The engineers or officers staffs are need the automatic program as presenting and developing like the researcher done.

CHAPTER V

RESULTS CONCLUSIONS AND RECOMMENDATIONS

5.1 Research conclusions

Information Management for Water Resource Management System of Huai Jorakhe Mak Reservoir Buriram province. Was based on System Development Life Cycle (SDLC) It has Linux redhat V.9 Unix network to supporting data communication. It is adapted for use with operation include of ANNs for automatic prototype forecasting water regulation for reservoir. The management of water resource was analysis from rainfall data regulating reservoir schedully for agriculturalists who need water from Huai Jorakhe Mak reservoir. The data had been collected completely and used to analyze for discussion about area for irrigation. Originally, the system was collecting by Excel program and operated by human manual which it might had some errors.

The designing and developing system could be separated into 3 phases of development. They were beginning phase of development, designing and developing adapted program as well as installing to test program.

Beginning phase of development, the results of the study had been presented as work flow diagram, data flow diagram and conceptual design.

Later, when detail and operational structure of developed Information System were known, the next step was to adapt program. The researcher has chosen small developed program in order to convenience and quick installation for easily operation, hoping to derive data of Huai Jorakhe Mak reservoir staffs by designing part of input data, analysis data and administrator or engineer to decision system include ANNs conceptual.

The final development involved the program installation and testing program with staff and administration at Huai jorakhe mak reservoir. The satisfaction were divided into marks which separated into 4 levels of excellent = 4, good = 3, fair = 2

and poor = 1. The results were shown in good level by questionnaire average points at 2.92 from 4.

The Information Management System for water resource management of Huai Jorakhe mak reservoir, Burirum province was installed at the irrigation project. The program could be summarized as following:

Benefits:

- Adding more data could be properly, easily and conveniently done.
- Easy to search, modify or erase data.
- Conveniently apply in operation without complication.
- Derived data for easy application.
- Appropriated structural system.
- Quick and reliable system in the next application.
- Supporting development in other system for further development.

Weaknesses:

- Limited data and out of date.
- Lacking necessary operational functions for regulate reservoir system.

5.2 Recommendations

Recommendation for the development of Information Management System for Water resource Management program could be separated into few major issues data, system, developer, and other areas as follows:

5.2.1 Data

1) The Developing Information Management System for Water resource Management of Huai Jorakhe Mak reservoir had found that the data for forecasting did not include effective rainfall so that this may results simulator has errored from current activated of regulate reservoir in rainy season.

2) The developer or programmer could be found the sample data and source code programming that on attachment from CDROM.

5.2.2 System

It found that the accessories to setup network of project irrigation incompletely for using in the future so the office should be created network system for

support Unix system and require the specialist for management server and database in the future.

5.2.3 Developer

Part of development system, the researcher used the open source code which supported unlimited development that shows on CDROM attachment.

For the future, the programmer or interesting peoples can develop this program completely by including some factors such as effective rainfall, soil moisture for the model completely.

5.2.4 Other areas

- The system need the reservoir regulation data as similar to actual regulation.
- The daily input data should be updated.
- The system could be increased the capacity to fulfill the water requirement at daily subcanal. Not only main canal.

REFERENCES

1. Stair, Ralph M. (1996). Principle of information system. Massachusetts :
Boyd&Fraser publish Co.,
2. Mason, J.C., Price, R.K. and Temme, A (1996). A Neuron Network Model of
Rainfall-Runoff Using Radial Basic Functions. J. Hydr. Res., 34(4), 537-
548.
3. วราวุธ วุฒินิชย์. (2543). การวิเคราะห์การถดถอยแบบถรรชนี. ชลกรฉบับวันชูชาติ. สมาคม
ศิษย์เก่าวิศวกรรมชลประทาน ในพระบรมราชูปถัมภ์. มกราคม. น. 101-105.
4. เจษฎา แก้วกัลยา. (2537-2538). การจัดการเรื่องน้ำ. วิทยาลัยการชลประทาน กรุงเทพฯ.
5. ชุมพล ศฤงคารศิริ (2538) ระบบสารสนเทศเพื่อการจัดการ พิมพ์ครั้งที่ 3. กรุงเทพฯ.
ป. สัมพันธ์พาณิชย์
6. ฉลอง เกิดพิทักษ์. (2538). การจัดการน้ำในลุ่มน้ำของประเทศไทย. กรุงเทพฯ: บริษัทโอเอเชียน
บลูพรินท์ จำกัด.
7. กอบเกียรติ ผ่องพุฒิ. (2528). การศึกษาการใช้น้ำในลุ่มน้ำลำพระเพลิง. วิทยานิพนธ์ปริญญา
มหาบัณฑิต ภาควิชาวิศวกรรมทรัพยากรน้ำ บัณฑิตวิทยาลัย
มหาวิทยาลัยเกษตรศาสตร์.
8. พงษ์ แมตสถาน. (2527). การจัดการการใช้น้ำเพื่อการชลประทานจากอ่างเก็บน้ำเขื่อนอุบล
รัตน์. วิทยานิพนธ์ปริญญามหาบัณฑิต ภาควิชาวิศวกรรมทรัพยากรน้ำ
บัณฑิตวิทยาลัย มหาวิทยาลัยเกษตรศาสตร์.
9. พรเทพ ราชวัคคี. (2534). การศึกษาการใช้น้ำของอ่างเก็บน้ำห้วยชันประดู่. วิทยานิพนธ์ปริญญา
มหาบัณฑิต ภาควิชาวิศวกรรมทรัพยากรน้ำ บัณฑิตวิทยาลัย
มหาวิทยาลัยเกษตรศาสตร์.
10. วิบูลย์ บุญยชโรกุล. (2526). หลักการชลประทาน. เอกสารประกอบการสอนวิชาวิศวกรรม
ชลประทาน คณะวิศวกรรมศาสตร์ มหาวิทยาลัยเกษตรศาสตร์ กรุงเทพฯ.
11. วราวุธ วุฒินิชย์. (2525). การจัดการเรื่องน้ำขั้นสูง. มหาวิทยาลัยเกษตรศาสตร์ วิทยาเขต
กำแพงแสน นครปฐม.

12. Allen, J., D.A., S., Crisp, N., Ruiz, S., Watts, S., Velez, P., Jornet, P., Rius, O., and Castellón, A. (1994). Upper ocean underway operations on bio hesperides cruise OMEGA-ALGERS (cruise 36) using SeaSoar and ADCP 30/09/96 - 14/10/96. Technical Report 17, Southampton Oceanography Center. 29 p
13. The Hydrological engineering center.(1976).HEC-3 Reservoir System analysis for Conservation . U.S.Army Corps of Hydrological engineering center, U.S.A. 66p
14. บริษัท ไทยทัวร์ อินโฟ จำกัด. แผนที่ท่องเที่ยวจังหวัดบุรีรัมย์ 2550. [Online] Available from :<http://www.thai-tour.com/thai-tour/Northeast/Buriram/data/map.htm> [Access 2007 Apr 15].
15. ข้อมูลโครงการชลประทานบุรีรัมย์. (2549). โครงการชลประทานจังหวัดบุรีรัมย์ กรมชลประทาน บุรีรัมย์.
16. Yang CC, Prasher S, Lacroix R, Sreekanth S, Patni NK, Masse L .(1997). Artificial neural network model for subsurface-drained farmlands . J. of irrigation and drainage engineering : 285-292 .
17. อรอนงค์ วรรณราช. (2546). การบริหารอ่างเก็บน้ำป่าสักชลสิทธิ์ โดยประยุกต์ใช้เทคนิคโครงข่ายประสาทเทียม. วิทยานิพนธ์ปริญญาโทมหาบัณฑิต ภาควิชาวิศวกรรมแหล่งน้ำ สาขาวิศวกรรมแหล่งน้ำ บัณฑิตวิทยาลัย จุฬาลงกรณ์มหาวิทยาลัย.
18. อาคม ไชยมงคล. (2545). การวิเคราะห์ศักยภาพการใช้น้ำของอ่างเก็บน้ำห้วยจรเข้มากอำเภอเมือง จังหวัดบุรีรัมย์ วิทยานิพนธ์ปริญญาโทมหาบัณฑิต ภาควิชาวิศวกรรมทรัพยากรน้ำ บัณฑิตวิทยาลัย มหาวิทยาลัยเกษตรศาสตร์.
19. รสกร ดำนกุล.(2546). การใช้โครงข่ายประสาทเทียมแบบ Backpropagation ในการพยากรณ์อัตราการไหลรายวัน กรณีศึกษาแม่น้ำปราจีนบุรี. วิทยานิพนธ์ปริญญาโทมหาบัณฑิต, สาขาวิศวกรรมทรัพยากรน้ำ บัณฑิตวิทยาลัย มหาวิทยาลัยเกษตรศาสตร์.

APPENDIX

APPENDIX A

Data dictionary

1. ตารางเทียบระดับน้ำสมมุติ

Fields	Type	Null	Key	Description
rsm	decimal(6,2)	NO	PRI	ระดับน้ำสมมุติ
totalwater	int(12)	YES		ปริมาณน้ำ
totalarea	int(12)	YES		พื้นที่ผิวน้ำ

2. ตารางปล่อยน้ำ เปิดปิดประตูระบายน้ำ

Fields	Type	Null	Key	Description
rid	int(12)	NO	PRI	ลำดับ
fdate	date	YES		วันที่
doorside	char(3)	YES		ประตูซ้าย-ขวา
timestart	char(5)	YES		เวลาเปิด
timestop	char(5)	YES		เวลาปิด
spillopen	decimal(6,2)	YES		ระดับเปิดประตู
rsmfront	decimal(6,2)	YES		ระดับน้ำสมมุติหน้า
rsmback	decimal(6,2)	YES		ระดับน้ำสมมุติหลัง
highwater	decimal(6,2)	YES		ระดับน้ำสูงหน้าบาน
waterqua	decimal(10,2)	YES		ปริมาณน้ำผ่านประตู
totalhr	decimal(6,2)	YES		รวมชม.
totalwater	decimal(10,2)	YES		ปริมาณน้ำรวมที่ปล่อย
rem	text	YES		หมายเหตุ

3. ตารางบันทึกปริมาณน้ำฝนรายวัน

Fields	Type	Null	Key	Description
fdate	date	NO	PRI	วันที่
totalrain	decimal(6,2)	YES		ปริมาณน้ำฝนรายวัน

4. ตารางระดับน้ำสมมุติรายวัน

Fields	Type	Null	Key	Description
fdate	date	NO	PRI	วันที่
rsmtotal	decimal(6,2)	YES		ระดับน้ำสมมุติรายวัน

5. ข้อมูลเชิงพื้นที่อ่างเก็บน้ำ

Fields	Type	Null	Key	Description
datein	date	NO	PRI	วันที่
rcapacity	decimal(20,5)	YES		อาณาเขตรับน้ำ
scapacity	decimal(20,5)	YES		พื้นที่เก็บกัก
deep	decimal(20,5)	YES		ความลึกสูงสุด
wmstorage	decimal(20,5)	YES		ความจุระดับเก็บกัก
wnstorage	decimal(20,5)	YES		ความจุระดับต่ำสุด
warea	decimal(20,5)	YES		ระดับพื้นผิวเก็บกัก
wincome	decimal(20,5)	YES		ปริมาณน้ำไหลเข้าอ่างต่อปี

6. ข้อมูลการใช้น้ำประปาท้องถิ่น

Fields	Type	Null	Key	Description
fromdate	date	NO	PRI	วันเริ่ม
todate	date	YES		วันสิ้นสุด
quantity	decimal(10,2)	YES		ปริมาณน้ำที่ต้องการใช้น้ำประปา

7. ข้อมูลพื้นที่เขตเพาะปลูกชลประทาน

Fields	Type	Null	Key	Description
fdate	date	NO	PRI	วันเริ่ม
area	int(10)	YES		ขนาดพื้นที่
rmcarea	decimal(10,3)	YES		พื้นที่ RMC
rmclong	decimal(10,3)	YES		ความยาว RMC
nwater	int(10)	YES		ความต้องการน้ำ RMC
lmcarea	decimal(10,3)	YES		พื้นที่ LMC
lmclong	decimal(10,3)	YES		ความยาว LMC
nwater1	int(10)	YES		ความต้องการน้ำคลองซอย 1 RMC
r1rmc	decimal(10,3)	YES		ความจุคลองซอย RMC 1
r1long	decimal(10,3)	YES		ความยาวคลองซอย RMC 1
nwater2	int(10)	YES		ความต้องการน้ำคลองซอย 2 RMC
r2rmc	decimal(10,3)	YES		ความจุคลองซอย RMC 2
r2long	decimal(10,3)	YES		ความยาวคลองซอย RMC 2
nwater3	int(10)	YES		ความต้องการน้ำคลองซอย 3 RMC
r3rmc	decimal(10,3)	YES		ความจุคลองซอย RMC 3
r3long	decimal(10,3)	YES		ความยาวคลองซอย RMC 3
nwater4	int(10)	YES		ความต้องการน้ำคลองซอย 4 rmc
r4rmc	decimal(10,3)	YES		ความจุคลองซอย RMC 4
r4long	decimal(10,3)	YES		ความยาวคลองซอย RMC 4
nwater5	int(10)	YES		ความต้องการน้ำคลองซอย 5 rmc
r5rmc	decimal(10,3)	YES		ความจุคลองซอย RMC 5

r5long	decimal(10,3)	YES		ความยาวคลองซอย RMC 5
				ความต้องการน้ำคลองซอย
l1rmc	int(10)	YES		1LMC
l1long	decimal(10,3)	YES		ความจุคลองซอย 1 LMC
nwaterl1	decimal(10,3)	YES		ความยาวคลองซอย 1 LMC
				ความต้องการน้ำคลองซอย
l2rmc	int(10)	YES		2LMC
l2long	decimal(10,3)	YES		ความจุคลองซอย 2 LMC
nwaterl2	decimal(10,3)	YES		ความยาวคลองซอย 2 LMC
				ความต้องการน้ำคลองซอย
l3rmc	int(10)	YES		3LMC
l3long	decimal(10,3)	YES		ความจุคลองซอย 3 LMC
nwaterl3	decimal(10,3)	YES		ความยาวคลองซอย 3 LMC
				ความต้องการน้ำคลองซอย
l4rmc	int(10)	YES		4LMC
l4long	decimal(10,3)	YES		ความจุคลองซอย 4 LMC
nwaterl4	decimal(10,3)	YES		ความยาวคลองซอย 4 LMC
				ความต้องการน้ำคลองซอย
l5rmc	int(10)	YES		5LMC
l5long	decimal(10,3)	YES		ความจุคลองซอย 5 LMC
nwaterl5	decimal(10,3)	YES		ความยาวคลองซอย 5 LMC

APPENDIX B

แบบสอบถามชุดที่

แบบสอบถามการใช้งานระบบ
เรื่อง การใช้ระบบสารสนเทศเพื่อการจัดการทรัพยากรน้ำของอ่างเก็บน้ำขนาดเล็ก
กรณีศึกษา : อ่างเก็บน้ำห้วยจรเข้มาก อ.เมือง จ.บุรีรัมย์

ส่วนที่ 1 ข้อมูลทั่วไปของผู้กรอกแบบสอบถาม

ทำเครื่องหมาย “✓” ลงในช่อง โดยให้ผู้ตอบคำถามกรอกเอง

1. ระดับการศึกษา ต่ำกว่าระดับปริญญาตรี ปริญญาตรี
 ปริญญาโท ปริญญาเอก

2. หน่วยงานสังกัด _____ ฝ่าย/แผนก/ส่วน _____

3. ท่านเคยใช้งาน โปรแกรมคอมพิวเตอร์ที่มี USER INTERFACE ผ่าน WEB BROWSER หรือไม่
 เคย ไม่เคย

3.1 ถ้าเคย โปรดระบุโปรแกรม _____

4. ท่านเคยใช้งาน โปรแกรมฐานข้อมูลหรือไม่
 เคย ไม่เคย

4.1 ถ้าเคย โปรดระบุโปรแกรม _____

ส่วนที่ 2 ข้อมูลความคิดเห็นเกี่ยวกับการใช้ระบบ

	ดีมาก	ดี	ปานกลาง	น้อย
1. ความสวยงามของโปรแกรม	<input type="checkbox"/>	<input type="checkbox"/>	<input type="checkbox"/>	<input type="checkbox"/>
2. ความง่ายของการใช้งาน	<input type="checkbox"/>	<input type="checkbox"/>	<input type="checkbox"/>	<input type="checkbox"/>
3. ความครบถ้วนของข้อมูล	<input type="checkbox"/>	<input type="checkbox"/>	<input type="checkbox"/>	<input type="checkbox"/>
4. ความสะดวกในการป้อนข้อมูลเข้าสู่ระบบ	<input type="checkbox"/>	<input type="checkbox"/>	<input type="checkbox"/>	<input type="checkbox"/>
5. ความสะดวกในการแก้ไขข้อมูล	<input type="checkbox"/>	<input type="checkbox"/>	<input type="checkbox"/>	<input type="checkbox"/>
6. ความรวดเร็วในการค้นหาข้อมูล	<input type="checkbox"/>	<input type="checkbox"/>	<input type="checkbox"/>	<input type="checkbox"/>
7. ความสะดวกในการออกรายงาน	<input type="checkbox"/>	<input type="checkbox"/>	<input type="checkbox"/>	<input type="checkbox"/>
8. ความรวดเร็วในการจำลองผล	<input type="checkbox"/>	<input type="checkbox"/>	<input type="checkbox"/>	<input type="checkbox"/>
9. ความถูกต้องในการจำลองผลข้อมูล	<input type="checkbox"/>	<input type="checkbox"/>	<input type="checkbox"/>	<input type="checkbox"/>
10. ระบบได้ทำการสนับสนุนหน่วยงานของท่านเพียงพอ	<input type="checkbox"/>	<input type="checkbox"/>	<input type="checkbox"/>	<input type="checkbox"/>
11. ความสามารถของระบบเมื่อเทียบกับระบบงานเดิม	<input type="checkbox"/>	<input type="checkbox"/>	<input type="checkbox"/>	<input type="checkbox"/>

ส่วนที่ 3 ข้อเสนอแนะ

.....

.....

.....

APPENDIX C

ผลคะแนนแบบสอบถามความพึงพอใจเกี่ยวกับระบบสารสนเทศเพื่อการจัดการทรัพยากรน้ำ

อ่างเก็บน้ำห้วยจรเข้มาก

คนที่ N	คะแนนข้อที่ (Xi)										
	1	2	3	4	5	6	7	8	9	10	11
1	3	3	3	3	3	3	3	3	3	3	3
2	2	3	3	3	3	3	3	3	3	2	3
3	3	4	3	3	3	3	3	3	3	4	3
4	3	4	3	3	3	3	3	3	3	3	3
5	3	2	3	3	3	3	4	2	2	3	2
6	3	3	3	3	3	3	2	2	3	2	3
7	3	3	3	3	3	4	3	3	3	2	3

หัวข้อ	ระดับคะแนน				รวม คะแนน	ผลรวม	ค่าเฉลี่ย
	ดีที่สุด 4	ดี 3	ปานกลาง 2	ต่ำ 1			
1.ความสวยงามของโปรแกรม		6	1		7	20	2.86
2.ความง่ายของการใช้งาน	2	4	1		7	22	3.14
3.ความครบถ้วนของข้อมูล		7			7	21	3.00
4.ความสะดวกในการเพิ่มข้อมูล		7			7	21	3.00
5.ความสะดวกในการแก้ไขข้อมูล		7			7	21	3.00
6.ความสะดวกในการค้นหาข้อมูล	1	6			7	22	3.14
7.ความสะดวกในการออกรายงาน	1	5	1		7	21	3.00
8.ความเร็วในการจำลองผล		5	2		7	19	2.71
9.ความถูกต้องของการจำลองผล		5	2		7	19	2.71
10.ระบบได้ทำการสนับสนุนหน่วยงาน ของท่านเพียงใด	1	3	3		7	19	2.71
11.ความสามารถของระบบเมื่อเทียบกับระบบงานเดิม		6	1		7	20	2.86
ค่าเฉลี่ยคะแนน							2.92

APPENDIX D

คู่มือการใช้งาน

การใช้งานทั่วไปของโปรแกรมระบบสารสนเทศเพื่อการจัดการทรัพยากรน้ำ ของอ่างเก็บน้ำห้วยจรเข้มาก โปรแกรมการใช้งาน จะใช้ Web Browser ทั่วๆ ไปที่มีอยู่ในคอมพิวเตอร์ ดังนี้

1. เข้าสู่ระบบ ให้พิมพ์ URL Address คือ http://10.0.0.2 โดยหน้าจอจะปรากฏดังนี้

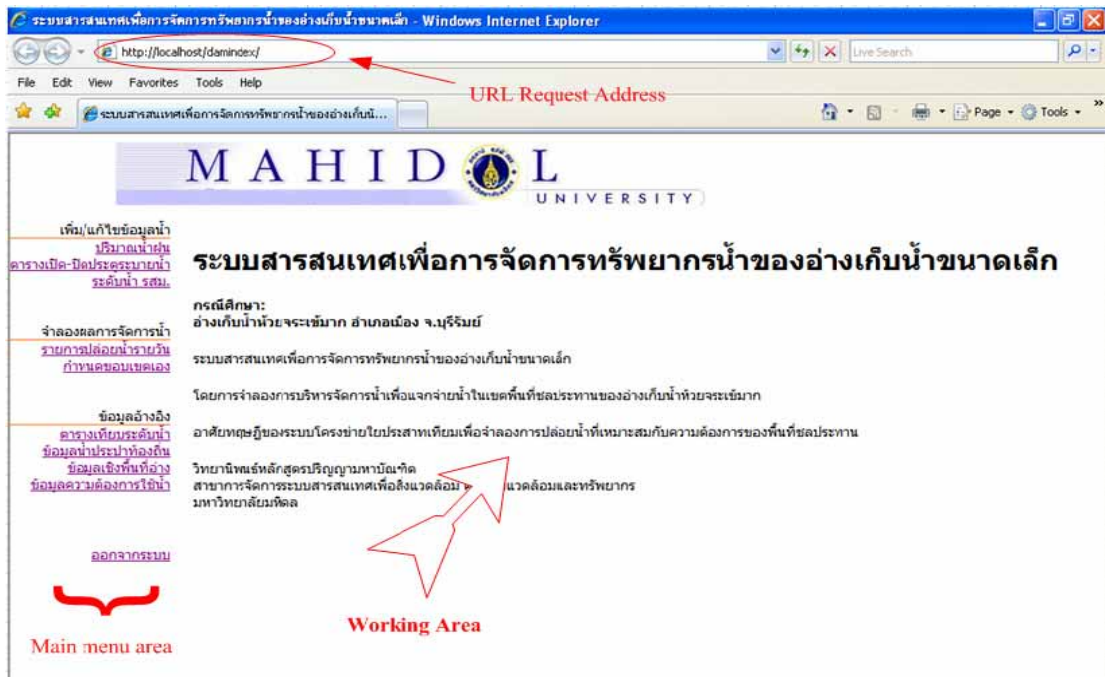

รูปที่ 1 แสดงหน้าจอหลัก

ทางซ้ายมือ จะเป็นเมนูต่างๆ และทางขวามือจะเป็นพื้นที่ใช้งาน โปรแกรม โดยแบ่งออกเป็น

FRAM

โดย Main menu ซ้ายมือจะประกอบไปด้วย

เพิ่มและแก้ไขข้อมูลน้ำ

- ปริมาณน้ำฝน เป็นการบันทึกแก้ไขปรับปรุง ปริมาณน้ำฝนรายวัน
- ตารางเปิด-ปิดประตูระบายน้ำ เป็นการบันทึกแก้ไขปรับปรุง ตารางเปิดปิดประตูระบายน้ำประจำวัน
- ระดับ รสม. เป็นการเพิ่มแก้ไขปรับปรุงข้อมูลปริมาณน้ำรายวันเทียบกับระดับน้ำสมมุติ

จำลองผลการจัดการน้ำ

- รายการปล่อยน้ำรายวัน เป็นการจำลองผลขอบเขตเพียง 1 วัน
- ขอบเขตกำหนดเอง เป็นการกำหนดขอบเขตการจำลองผลเอง

ข้อมูลอ้างอิง

- ตารางเทียบระดับน้ำ เป็นตารางเทียบระดับน้ำสมมุติ และปริมาณน้ำในขอบเขตของระดับน้ำสมมุติ
- ข้อมูลการใช้น้ำประปาท้องถิ่น บันทึกเข้ารายปี
- ข้อมูลเชิงพื้นที่อ่างเก็บน้ำ
- ข้อมูลความต้องการใช้น้ำเพื่อการเกษตรในเขตพื้นที่

หลังจากเข้าสู่หน้าจอแรกแล้ว การปฏิบัติงานในส่วนของเพิ่ม แก้ไขข้อมูลน้ำ และข้อมูลอ้างอิง ผู้ใช้งานต้องมีรหัสผ่าน เพื่อเข้าสู่การใช้งาน ดังนี้

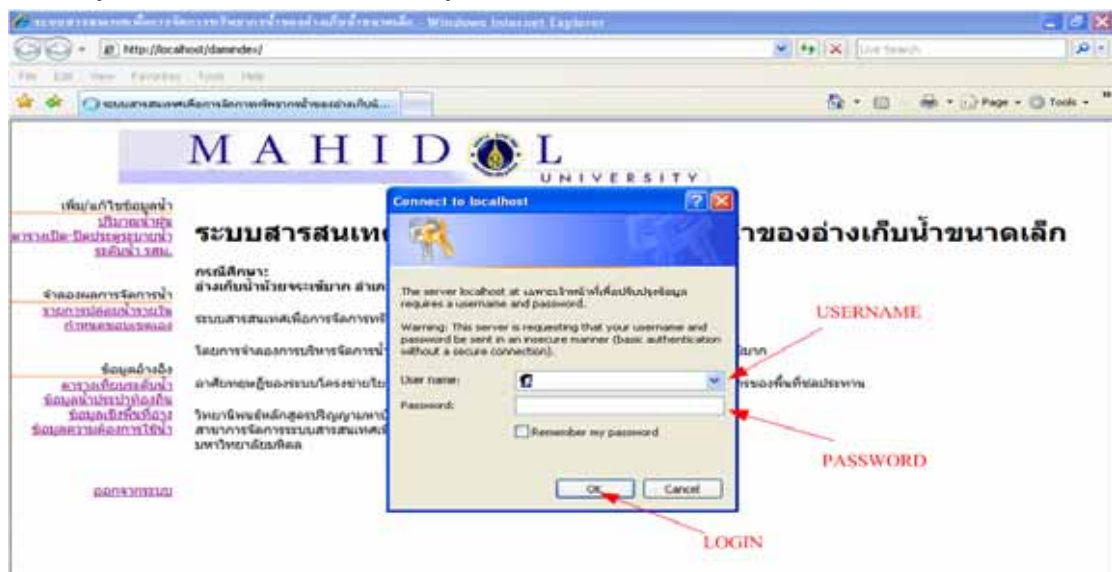

รูปที่ 2 แสดงหน้าจอเพื่อกรอกรหัสผ่าน

จากหน้าจอนี้ผู้ได้รับมอบหมายจะทำการพิมพ์รหัสผ่านเพื่อเข้าไปใช้งานของโปรแกรมต่างๆ ของระบบ แต่สำหรับการจำลองผล จะไม่ต้องใช้รหัสผ่าน สามารถจำลองผลได้ทันทีจากหน้าจอแรก และจากข้อมูลที่มีอยู่

วันที่	ปริมาณน้ำฝน
13/09/2543	102.00
14/09/2543	0.00
15/09/2543	0.00
16/09/2543	0.00
17/09/2543	0.00
18/09/2543	0.00
19/09/2543	0.00
20/09/2543	0.00
21/09/2543	10.00
22/09/2543	0.00
23/09/2543	0.00
24/09/2543	0.00
25/09/2543	0.00
26/09/2543	46.00
27/09/2543	18.30
28/09/2543	4.00
29/09/2543	0.00
30/09/2543	0.00
01/10/2543	0.00
02/10/2543	0.00
03/10/2543	0.00

รูปที่ 3 แสดงหน้าจอข้อมูลปริมาณน้ำฝน

วันที่	MC	เวลาเปิด	เวลาปิด	สถานะ	สม.น้ำเข้า	สม.น้ำออก	ความสูงระดับน้ำ	ปริมาณน้ำฝน	จำนวน หน.	จากปริมาณน้ำฝน	ขนาดประตู
1	13/09/2543	LMC		0.25	162.11	160.14	1.97	0.6180	24.00	53390.20	
2	14/09/2543	LMC		0.25	162.21	160.48	1.73	0.5790	24.00	50025.60	
3	15/09/2543	LMC		0.25	162.38	160.21	2.17	0.6490	24.00	56073.60	
4	16/09/2543	LMC		0.25	162.53	160.19	2.36	0.6760	24.00	58406.40	
5	17/09/2543	LMC		0.23	162.39	160.19	2.40	0.6820	24.00	58924.80	
6	18/09/2543	LMC		0.23	162.58	160.19	2.39	0.6810	24.00	58838.40	
7	19/09/2543	LMC		0.25	162.58	160.23	2.34	0.6740	24.00	58233.60	
8	20/09/2543	LMC		0.10	162.53	159.33	2.70	0.1890	24.00	16329.60	
9	21/09/2543	LMC		0.10	162.47	159.24	2.73	0.1900	24.00	16416.00	
10	22/09/2543	LMC		0.10	162.45	159.29	2.66	0.1870	24.00	16156.00	
11	23/09/2543	LMC		0.10	162.45	159.23	2.70	0.1890	24.00	16329.60	
12	24/09/2543	LMC		0.10	162.45	159.23	2.68	0.1880	24.00	16243.20	
13	25/09/2543	LMC		0.10	162.51	159.26	2.66	0.1870	24.00	16156.00	
14	26/09/2543	LMC		0.10	162.45	159.93	2.47	0.1800	24.00	15352.00	
15	27/09/2543	LMC		0.10	162.47	160.08	2.36	0.1760	24.00	15206.40	
16	28/09/2543	LMC		0.10	162.46	160.09	2.34	0.1770	24.00	15292.80	
17	29/09/2543	LMC		0.10	162.48	160.02	2.41	0.1780	24.00	15379.20	
18	30/09/2543	LMC		0.11	162.49	159.76	2.73	0.1900	24.00	16416.00	
19	01/10/2543	LMC		0.10	162.50	159.76	2.74	0.1900	24.00	16416.00	
20	02/10/2543	LMC		0.10	162.51	159.76	2.75	0.1910	24.00	16416.00	
21	03/10/2543	LMC		0.10	162.51	159.76	2.76	0.1910	24.00	16416.00	
22	04/10/2543	LMC		0.15	162.51	160.00	2.51	0.1320	24.00	45964.80	
23	05/10/2543	LMC		0.15	162.50	160.08	2.42	0.3260	24.00	28166.40	
24	06/10/2543	LMC		0.15	162.50	160.17	2.33	0.3200	24.00	27648.00	
25	07/10/2543	LMC		0.15	162.49	160.01	2.48	0.3310	24.00	28398.40	
26	08/10/2543	LMC		0.15	162.49	160.01	2.49	0.3310	24.00	28398.40	
27	09/10/2543	LMC		0.15	162.48	160.01	2.47	0.3290	24.00	28312.00	
28	10/10/2543	LMC		0.15	162.48	160.01	2.47	0.3300	24.00	28312.00	

รูปที่ 4 แสดงหน้าจอข้อมูลตารางเปิดปิดประตูระบายน้ำ

ระดับน้ำ

วันที่	ระดับน้ำ
13/09/2543	162.11
14/09/2543	162.21
15/09/2543	162.38
16/09/2543	162.55
17/09/2543	162.59
18/09/2543	162.58
19/09/2543	162.57
20/09/2543	162.53
21/09/2543	162.47
22/09/2543	162.45
23/09/2543	162.43
24/09/2543	162.41
25/09/2543	162.39
26/09/2543	162.40
27/09/2543	162.42
28/09/2543	162.46
29/09/2543	162.48
30/09/2543	162.49
01/10/2543	162.50
02/10/2543	162.51

รูปที่ 5 แสดงรายการเทียบระดับน้ำสมมุติรายวัน

เทียบระดับน้ำ

รสม.	ความจ	พื้นที่ผิวน้ำ
158.00	142925	382820
158.01	148547	401237
158.02	154169	419654
158.03	159791	438071
158.04	165413	456488
158.05	171035	474905
158.06	176657	493322
158.07	182279	511739
158.08	187901	530156
158.09	193523	548573
158.10	199145	566990
158.11	204767	585407
158.12	210389	603824
158.13	216011	622241
158.14	221633	640658
158.15	227255	659075
158.16	232877	677492
158.17	238499	695909
158.18	244121	714326
158.19	249743	732743

รูปที่ 6 แสดงรายการเทียบระดับน้ำและปริมาณน้ำ

ระบบสารสนเทศเพื่อการบริหารทรัพยากรน้ำของอ่างเก็บน้ำขนาดใหญ่ - Windows Internet Explorer

http://localhost/damindex/

File Edit View Favorites Tools Help

ระบบสารสนเทศเพื่อการบริหารทรัพยากรน้ำของอ่างเก็บน้ำ...

MAHIDOL UNIVERSITY

ความต้องการใช้น้ำประปา

เพิ่ม/แก้ไขข้อมูลน้ำ
ปริมาณน้ำฝน
ตารางเปิด-ปิดประตูระบายน้ำ
ระดับน้ำ รสม.

จำลองผลการจัดการน้ำ
รายการปล่อยน้ำรายวัน
กำหนดขอบเขตเอง

ข้อมูลอ้างอิง
ตารางเทียบระดับน้ำ
ข้อมูลน้ำประปาท้องถิ่น
ข้อมูลเชิงพื้นที่อ่าง
ข้อมูลความต้องการใช้น้ำ

ออกจากระบบ

Quick Search FIND IT!

PRINT PREVIEW FILTERS RESET FILTERS Go to table

จากวันที่	ถึงวันที่	ปริมาณน้ำ
01/01/2545	31/12/2545	7000.00
01/01/2544	31/12/2544	7000.00
01/01/2546	31/12/2546	7000.00
01/01/2547	31/12/2547	7000.00
01/01/2548	31/12/2548	7000.00
01/01/2549	31/12/2549	7000.00
01/01/2550	31/12/2550	7000.00

PREVIOUS **Records 1 to 7 of 7** NEXT

แสดงรายการ

จากวันที่ 24 / มี.ค / ADD NEW

ถึงวันที่ 24 / มี.ค /

ปริมาณน้ำ ลบ.ม

รูปที่ 7 แสดงข้อมูลการใช้น้ำประปาท้องถิ่น

ระบบสารสนเทศเพื่อการบริหารทรัพยากรน้ำของอ่างเก็บน้ำขนาดใหญ่ - Windows Internet Explorer

http://localhost/damindex/

File Edit View Favorites Tools Help

ระบบสารสนเทศเพื่อการบริหารทรัพยากรน้ำของอ่างเก็บน้ำ...

MAHIDOL UNIVERSITY

ข้อมูลเชิงพื้นที่

เพิ่ม/แก้ไขข้อมูลน้ำ
ปริมาณน้ำฝน
ตารางเปิด-ปิดประตูระบายน้ำ
ระดับน้ำ รสม.

จำลองผลการจัดการน้ำ
รายการปล่อยน้ำรายวัน
กำหนดขอบเขตเอง

ข้อมูลอ้างอิง
ตารางเทียบระดับน้ำ
ข้อมูลน้ำประปาท้องถิ่น
ข้อมูลเชิงพื้นที่อ่าง
ข้อมูลความต้องการใช้น้ำ

ออกจากระบบ

Quick Search FIND IT!

PRINT PREVIEW SAVE CSV FILTERS RESET FILTERS Go to table

วันที่บันทึก	สถานะระดับน้ำฝน	พื้นที่เก็บกัก	ความลึกสูงสุด	ความจุระดับเก็บกักสูงสุด
31/12/2549	113.64000	7900.00000	7.00000	27363000.00000

PREVIOUS **Records 1 to 1 of 1** NEXT

วันที่บันทึก 24 / มี.ค / ADD NEW

สถานะระดับน้ำฝน ตร.กม.

พื้นที่เก็บกัก ไร่

ความลึกสูงสุด เมตร

ความจุระดับเก็บกักสูงสุด ลบ.ม

ความจุระดับน้ำต่ำสุด ลบ.ม

ความจุระดับเก็บกัก ตร.กม.

ปริมาณน้ำไหลเข้าอ่างเฉลี่ยต่อปี ลบ.ม.

รูปที่ 8 ข้อมูลเชิงพื้นที่ของอ่างเก็บน้ำ

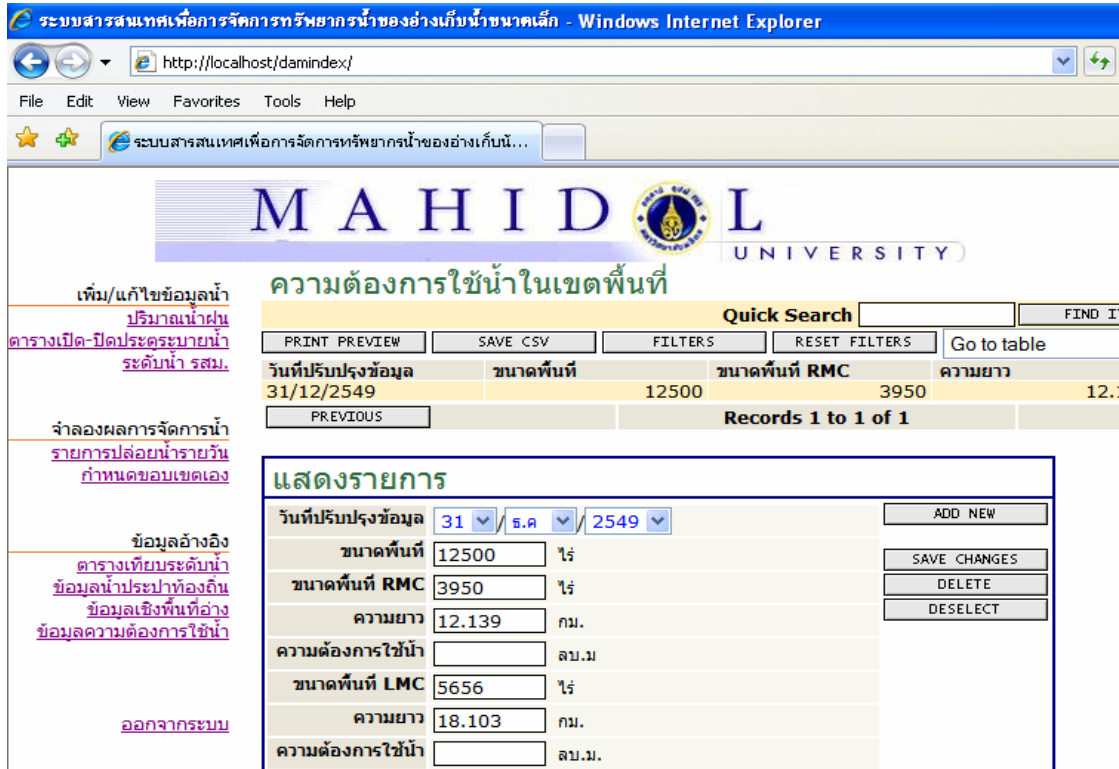

รูปที่ 9 ข้อมูลความต้องการใช้น้ำในเขตพื้นที่

จากรูปของหน้าจอต่างๆ ที่กล่าวมาข้างต้น ผู้ใช้งานจะต้องมีรหัสผ่านเพื่อเข้าดำเนินการเพิ่มแก้ไข ปรับปรุงข้อมูล หรือออกรายงานต่างๆ โดยหน้าจอสำหรับการเพิ่มแก้ไขข้อมูลดังนี้

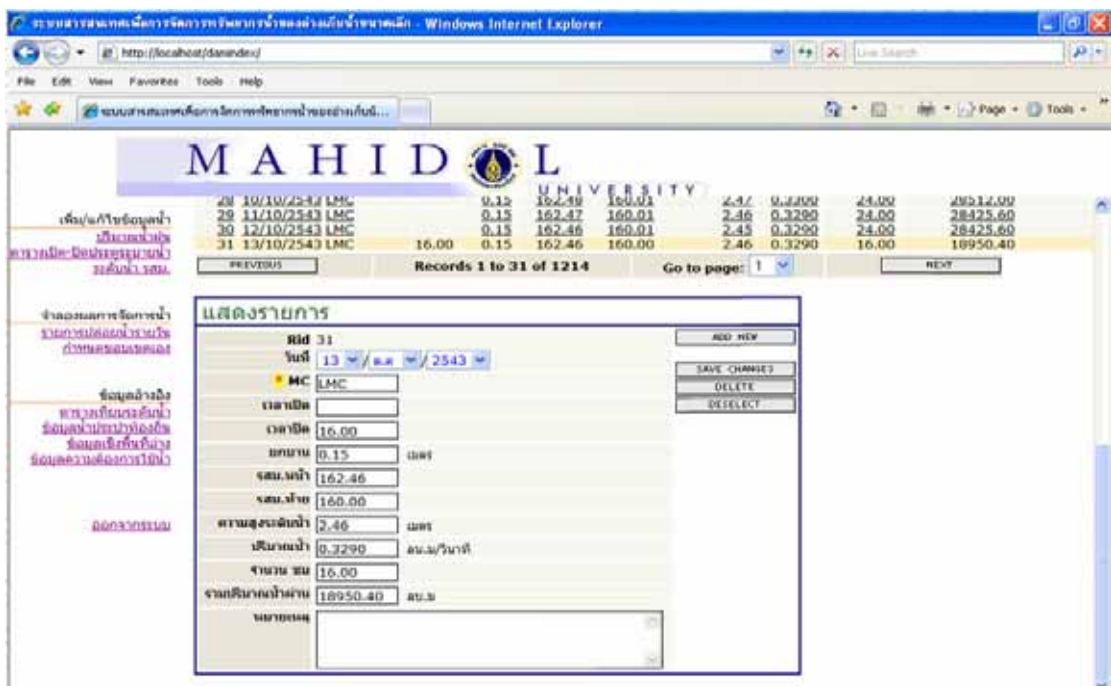

รูปที่ 10 แสดงหน้าจอการเพิ่มข้อมูล

โดยหน้าจอนี้ จะมีรายละเอียดสำคัญดังนี้

ปุ่ม ADD NEW เป็นปุ่มเพิ่มจำนวนรายการ เมื่อมีการพิมพ์เสร็จแล้วใจช่องของ input box

ปุ่ม SAVE CHANGE เป็นปุ่มที่ใช้ในการบันทึกข้อมูลที่มีการแก้ไขผ่านทาง input box

ปุ่ม DELETE เป็นปุ่มที่ใช้ลบข้อมูล

ปุ่ม DESELECT เป็นปุ่มที่ใช้ยกเลิกรายการที่แสดงอยู่หน้าจอปัจจุบัน

การใช้ข้อมูลแสดงผล จะมีปุ่ม NEXT เพื่อแสดงผลหน้าจอถัดไป หรือ ปุ่ม PREVIOUS ที่ใช้สำหรับแสดงหน้าจอย้อนหลังกลับมา โดยในจำนวนรายการข้อมูลที่แสดงบนหน้าจอ สามารถจะเลื่อนเมา์ไปคลิกที่รายการนั้นๆ ได้ และรายการก็จะแสดงข้อมูลรายการที่ input box เป็นรายละเอียดของรายการนั้นๆ

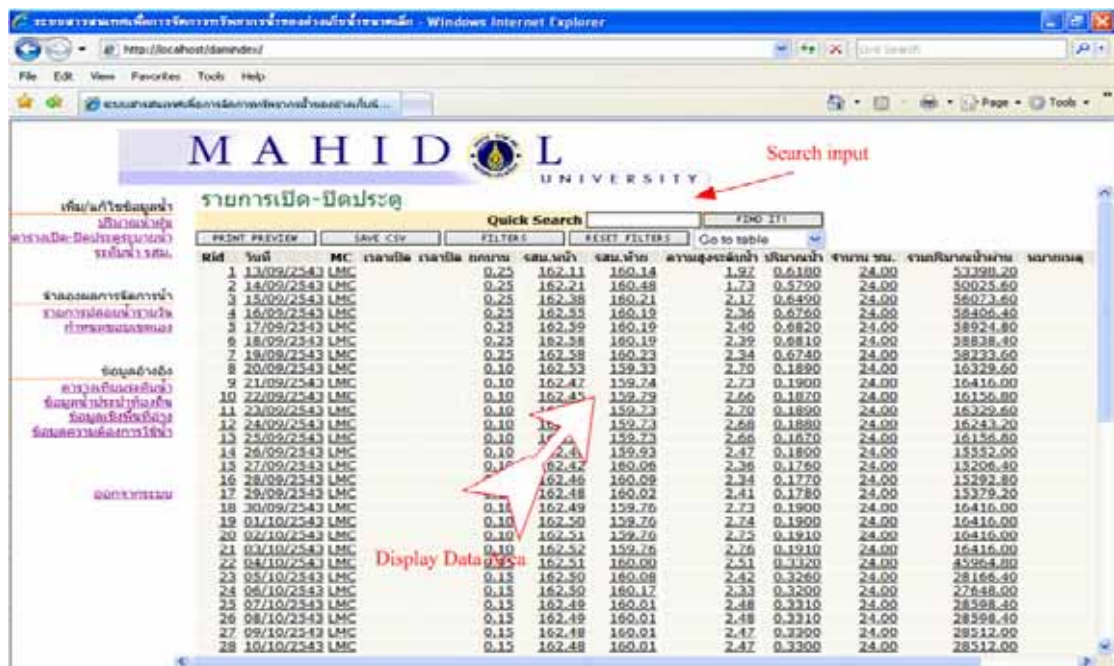

รูปที่ 16 แสดงรายการ

การค้นหาข้อมูล จะทำการกดที่ปุ่ม FIND IT ได้ทันที ต้องกรอกข้อมูลลงใน input box ของ Quick Search ก่อน โดยข้อความ หรือคำที่กรอกลงนั้น จะแสดงขึ้นมาเป็นรายการของพื้นที่แสดงข้อมูล โดยสามารถค้นหาข้อมูลได้ทุกคำและทุกข้อมูลใน fields นั้นๆ

การค้นหาโดยมีเงื่อนไขที่ลึกกว่านั้น ดังนี้

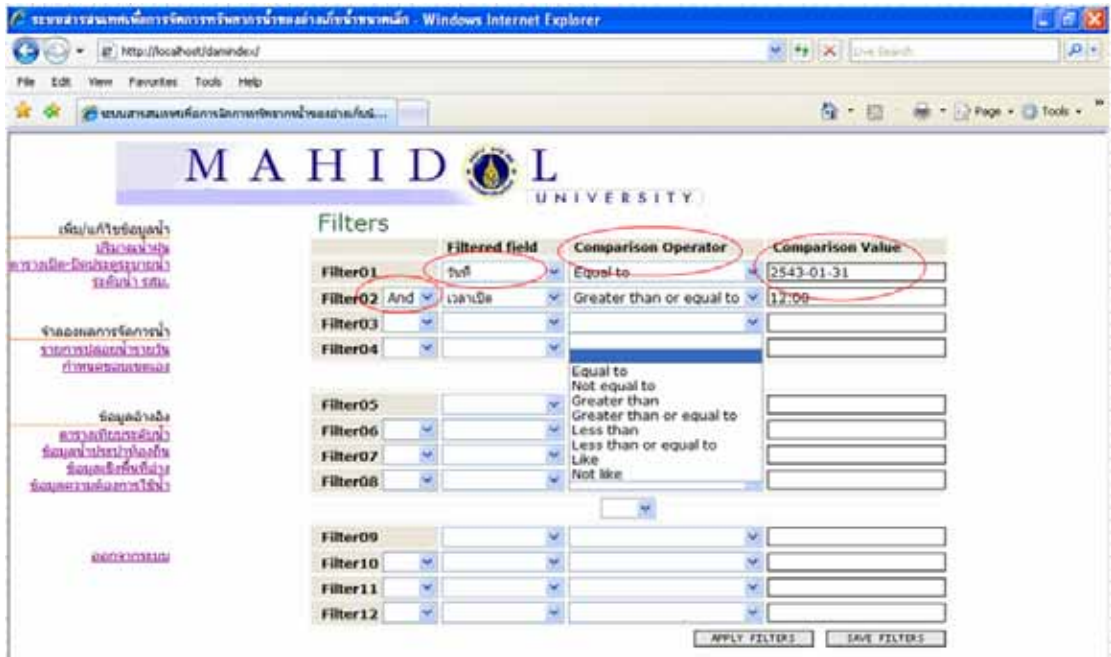

รูปที่ 17 แสดงการค้นหาแบบมีเงื่อนไข

โดยสามารถกดเข้าที่หน้าจอนี้ผ่านทางปุ่ม Filter โดยมีรายละเอียดสำคัญคือ Filtered fields เป็น Fields ที่ต้องการค้นหา โดยจะเป็น scroll bar ให้เลือก Comparison Operator เป็นการเปรียบเทียบ จาก Fields และค่าที่ต้องการค้นหา โดยมี Operator ดังนี้ < <= > = เหมือน ไม่เหมือน เท่ากับ ไม่เท่ากับ เป็นต้น Comparison Value เป็นค่าที่ต้องการค้นหา

จาก Filter ที่มากกว่า 1 ก็จะมี Comparison operator ที่เป็น AND OR เพื่อเปรียบเทียบข้อมูลอีกครั้ง

หน้าจอการเพิ่มข้อมูล และหน้าจอการหน้าจอกำหนดการค้นหาข้อมูล จะเป็นหน้าจอที่มีลักษณะเดียวกันกับทุกโปรแกรม โดยผู้ใช้งานสามารถ เห็นหน้าจอที่แสดงออกในรูปแบบเดียวกันกับทุกหมคการใช้งาน จึงทำให้ง่ายต่อการใช้งานของผู้ใช้

การแสดงผลแบบจำลอง จะเป็นหน้าจอที่ผู้ต้องการแสดงผล ต้องกรอกข้อมูลเริ่มต้น และข้อมูลสิ้นสุด โดยจะเป็นวันที่ Format YYYY-MM-DD คือเริ่มจาก ปี เดือน วัน และกดปุ่มจำลองผล เพื่อให้ระบบได้จำลองผลการป้อนน้ำในอนาคต หรืออดีตที่ผ่านมาได้ ดังนี้

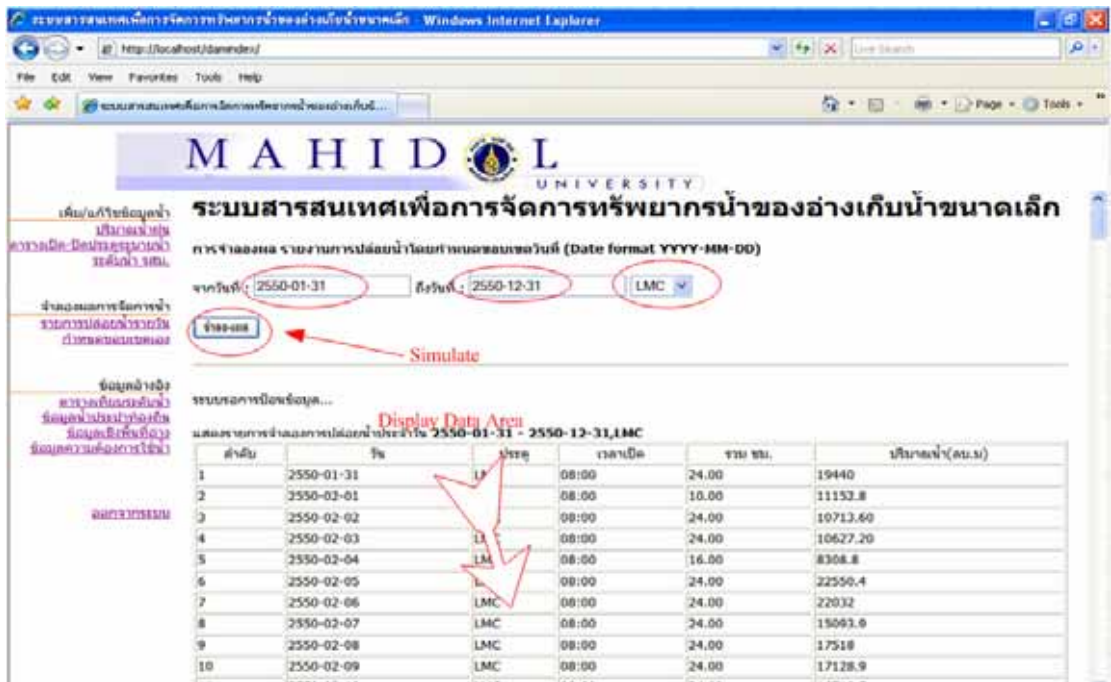

รูปที่ 18 แสดงหน้าจอการจำลองผล

การแสดงผลที่ได้จากการจำลองผล มีรายละเอียดที่แสดงดังต่อไปนี้

วัน แสดง วันที่ ที่ต้องการจำลองผล

ประจุ เป็นประจุที่ต้องการจำลองผล LMC และ RMC

เวลาเปิด เป็นเวลาเปิดประตูระบายน้ำ

รวมจำนวนชั่วโมง เป็นจำนวนชั่วโมงรวมต่อการเปิดประตูระบายน้ำครั้งนั้นๆ

ปริมาณน้ำ จะมีหน่วยเป็นลูกบาศก์เมตร ซึ่งจำลองเอาปริมาณที่เหมาะสมออกมา

แสดงผล

ทั้งนี้ การแสดงผล สามารถกำหนดขอบเขตตามต้องการได้

BIOGRAPHY

NAME	Mr. Sooktawee Singhtee
DATE OF BIRTH	01 March 1974
PLACE OF BIRTH	Buriram, Thailand
INSTITUTIONS ATTENDED	Rajabhat Suandusit Institute, 1994: B.A. (Library Science and Information Management Science) Mahidol University, 2007: M.Sc.(Information Management on Environments and Resources)
HOME ADDRESS	90/655, Piyawararom, Bangboathong, Nonthaburi Thailand 11000 E-mail: vee_a@hotmail.com