

**NOISE REDUCTION
OF JEWELRY CLEANING MACHINE**

JARUWAN LADORNDOO

**A THESIS SUBMITTED IN PARTIAL FULFILLMENT
OF THE REQUIREMENTS FOR THE DEGREE OF MASTER OF
SCIENCE (OCCUPATIONAL HEALTH AND SAFETY)
FACULTY OF GRADUATE STUDIES
MAHIDOL UNIVERSITY
2015**

COPYRIGHT OF MAHIDOL UNIVERSITY

Thesis
entitled
**NOISE REDUCTION
OF JEWELRY CLEANING MACHINE**

Jaruwan Ladorndoo

.....
Miss Jaruwan Ladorndoo
Candidate

Pk Osiri

.....
Assoc.Prof. Pramuk Osiri,
Sc.D. (Industrial Hygiene)
Major advisor

[Signature]

.....
Assoc.Prof. Somporn Kantharadussadee-
Triamchaisri,
Ph.D. (Neuroscience)
Co-advisor

Boonyayothin V.

.....
Lect. Vorakamol Boonyayothin,
Ph.D. (Energy Technology)
Co-advisor

Orawan Kaewboonchoo

.....
Assoc.Prof. Orawan Kaewboonchoo,
Ph.D. (Medical Science)
Co-advisor

A. Mutchimwong

.....
Asst. Prof. Auemphorn Mutchimwong,
Ph.D. (Air Quality Assessment)
Acting Dean
Faculty of Graduate Studies
Mahidol University

[Signature]

.....
Lect. Noppanun Nankongnab,
Ph.D. (Energy Technology)
Program Director
Master of Science Program in
Occupational Health and Safety
Faculty of Public Health,
Mahidol University

Thesis
entitled
**NOISE REDUCTION
OF JEWELRY CLEANING MACHINE**

was submitted to the Faculty of Graduate Studies, Mahidol University
for the degree of Master of Science (Occupational Health and Safety)
on
February 28, 2015

Jaruwan Ladorndoo

Miss Jaruwan Ladorndoo
Candidate

P. Chongvisal

Assoc.Prof. Noppakorn Chongvisal,
Ph.D.(Industrial Hygiene)
Chair

P. Osiri

Assoc.Prof. Pramuk Osiri,
Sc.D. (Industrial Hygiene)
Member

S. Kantharadussadee

Assoc.Prof. Somporn Kantharadussadee-
Triamchaisri,
Ph.D. (Neuroscience)
Member

Boonyayotin V.

Lect. Vorakamol Boonyayothin,
Ph.D. (Energy Technology)
Member

Orawan Kaewboonchoo

Assoc.Prof. Orawan Kaewboonchoo,
Ph.D. (Medical Science)
Member

A. Mutchimwong

Asst. Prof. Auemphorn Mutchimwong,
Ph.D. (Air Quality Assessment)
Acting Dean
Faculty of Graduate Studies
Mahidol University

P. Fong

Assoc.Prof. Prayoon Fongsathitkul,
Ph.D. (Environmental Engineering)
Dean
Faculty of Public Health
Mahidol University

ACKNOWLEDGMENTS

The success of this thesis can be attributed to the extensive support and assistance from major advisor, Assoc.Prof. Pramuk Osiri and co-advisor, Assoc.Prof.Dr. Somporn kantharadussadee-Triamchaisri, Lect.Dr.Vorakamol Boonyayothin, Assoc.Prof.Dr. Orawan Kaewboonchoo, I would like to thanks to them for their advice in this research.

Thanks to the Armacell (Thailand) Co., Ltd. for support the material for this research and also thanks to Chemlab Co., Ltd. for support the instrument for sound levels measurement.

I am grateful to all the lecturers and staffs of the Occupational Health and Safety Department for their advice and thanks to my friends for their kind support.

I am grateful to my family for their encouragement, entirely care, and love. The usefulness of this thesis, I dedicate to my father, my mother and all the teachers who have taught me all the time.

Jaruwan Ladorndoo

NOISE REDUCTION OF JEWELRY CLEANING MACHINE

JARUWAN LADORNDUO 5536387 PHOH/M

M.Sc. (OCCUPATIONAL HEALTH AND SAFETY)

THESIS ADVISORY COMMITTEE: PRAMUK OSIRI, Sc.D.,(INDUSTRIAL HYGIENE), SOMPORN KANTHARADUSSADEE TRIAMCHAI SRI, Ph.D.,(NEUROSCIENCE), ORAWAN KAEWBOONCHOO, Ph.D.,(MEDICAL SCIENCE), VORAKAMOL BOONYAYOTHIN, Ph.D.,(ENERGY TECHNOLOGY)

ABSTRACT

The objective of this study is to learn and compare the noise levels from the processes of a jewelry cleaning machine. The result of workplace monitoring before the improvement found that the noise levels during an 8 hrs working a day was 92.5 dB(A). The workers that were exposed to noise above 85 dB(A) for 8 work hours caused by a jewelry cleaning machine (which is 54 cm wide, 110 cm long, and 110 cm high). Noise absorbent material, made from Elastomeric foam based on synthetic rubber, was installed on 6 sides of the internal machinery and rubber seals helped to reduce the spread of the noise and reduce sound transmission through the air. The noise levels were measured at 7 points at dB(A), dB(C) and at frequencies ranging from 125 Hz to 5 KHz.

A comparison of the noise levels results between, before, and after, the improvements at the 7 points (front left, the front middle, the front right, the side, the back, the top, and the bottom) revealed that the noise levels decreased by 0.8-7.9 dB(C), with the biggest decrease at the frequency of 5 KHz.

KEY WORDS: NOISE INDUCED HEARING LOSS/ ABSORPTION MATERIAL/
SOUND ABSORPTION COEFFICIENT/ NOISE REDUCTION

91 pages

การลดเสียงจากเครื่องล้างทำความสะอาดเครื่องประดับ

NOISE REDUCTION OF JEWELRY CLEANING MACHINE

จากรรณ หล้าคอนดู๋ 5536387 PHOH/M

วท.ม. (อาชีวอนามัยและความปลอดภัย)

คณะกรรมการที่ปรึกษาวิทยานิพนธ์ : ประมุข โอศิริ ,Sc.D.(INDUSTRIAL HYGIENE),
สมพร กันทรคุชฎี เตรียมชัยศรี, Ph.D., (NEUROSCIENCE), อรวรรณ แก้วบุญชู, PhD.,
(MEDICAL SCIENCE), รกมล บุญยโยธิน, PhD. (ENERGY TECHNOLOGY)

บทคัดย่อ

วัตถุประสงค์ของการศึกษานี้ คือ เพื่อศึกษาระดับเสียงที่เกิดขึ้นจากการทำงานของเครื่องจักรที่มีในพื้นที่การทำงาน และเพื่อเปรียบเทียบระดับความดังเสียงก่อนและหลังการปรับปรุงเครื่องทำความสะอาดชิ้นงาน ผลจากการตรวจวัดระดับเสียงก่อนปรับปรุงตลอดระยะเวลาการทำงาน 8 ชั่วโมงในกระบวนการฉีดล้างชิ้นงานในอุตสาหกรรมผลิตและประกอบเครื่องประดับ ตรวจวัดได้ 92.5 dB (A) ซึ่งมากกว่าที่มาตรฐานกฎหมายกำหนดให้ผู้ปฏิบัติงานที่สัมผัสเสียงดังเกิน 85 dB (C) ใน 8 ชั่วโมงการทำงาน ซึ่งเป็นเสียงที่เกิดจากเครื่องทำความสะอาดชิ้นงานที่มีขนาด 54 ซม. ยาว 110 ซม. และสูง 110 ซม. ทำการติดตั้งวัสดุดูดซับเสียง Syntactic Rubber ภายในเครื่องจักร ทั้งหมด 6 ด้าน และการติดแผ่นพลาสติกกันช่องสอดมือ เพื่อลดการแพร่ของเสียงและลดการส่งผ่านเสียงทางอากาศ และทำการตรวจวัดระดับเสียงจำนวน 7 จุด ที่ระดับ dB(A), dB(C) และระดับเสียงแยกความถี่ตั้งแต่ 125 Hz ถึง 5 KHz

ผลการเปรียบเทียบระดับเสียงก่อนและหลังทำการปรับปรุงทั้ง 7 จุด ได้แก่ ด้านหน้าฝั่งซ้ายมือ, ด้านหน้าตรงกลาง, ด้านหน้าฝั่งขวา, ด้านข้าง, ด้านหลัง, ด้านบน และด้านล่าง พบว่าระดับเสียงลดลง 0.8-7.9 dB(C) ซึ่งส่วนใหญ่ระดับเสียงลดลงที่ความถี่สูงสุดคือ 5 KHz.

CONTENTS

	Page
ACKNOWLEDGEMENTS	iii
ABSTRACT (ENGLISH)	iv
ABSTRACT (THAI)	v
LIST OF TABLES	viii
LIST OF FIGURES	x
CHAPTER I INTRODUCTION	
1.1 Background and Rationale	1
1.2 Objective	3
1.3 Hypothesis	3
1.4 Variables	3
1.5 Conceptual Frameworks	4
1.6 Definition Terminology	4
1.6 Scope of the study	4
1.8 Limitation	6
1.9 Expectation of the benefits	6
CHAPTER II LITERATURE REVIEW	
2.1 Basic of Sound	7
2.2 Sound measurement	13
2.3 Analysis and Assessment	20
2.4 The effect of sound on health	22
2.5 Noise control basic concept terms	27
2.6 Related research work	33
CHAPTER III MATERIALS AND METHODS	
3.1 Study designed	36
3.2 Data collection	42

CONTENTS (cont.)

	Page
3.3 Material and Equipment	44
3.4 Statistic analysis	44
CHAPTER IV RESULTS	
4.1 Primary survey and preparation of appropriated tools	45
4.2 Improvement of Noise reduction of Jewelry Cleaning Machine	47
4.3 A measure of sound levels “before” and “after” some adjustment of the jewelry cleaning machine	47
CHAPTER V DISCUSSION	71
CHAPTER VI CONCLUSION AND RECOMMENDATION	
6.1 Conclusion	73
6.2 Recommendations	75
REFERENCES	76
APPENDICES	78
Appendix A The jewelry cleaning machine	79
Appendix B Noise measurements	80
Appendix C Result of sound levels measurement	87
BIOGRAPHY	91

LIST OF TABLES

Table	Page
2-1 Standardization of measuring instruments	17
2-2 Correction for background noise contribution in sound measurements	19
2-3 Specifies levels of continuous sound and level of intermittent sound	20
2-4 The standardization of sound stipulated by OSHA	21
2-5 The standardization of sound stipulated of the day	21
3-1 The absorption efficient of the super silence	39
3-2 Types of sound proof material identified from the noise reduction coefficient. (Noise Reduction Coefficient, NRC)	41
4-1 The result of noise monitoring in Cleaning Process	46
4-2 The result of noise attenuation at front of machine (Left) before improvement.	48
4-3 The result of noise attenuation at front of machine (Middle) before improvement.	50
4-4 The result of noise attenuation at front of machine (Right) before improvement.	51
4-5 The result of noise attenuation at Beside of machine before improvement.	53
4-6 The result of noise attenuation at Rear of machine before improvement.	54
4-7 The result of noise attenuation at Above of machine before improvement.	55
4-8 The result of noise attenuation at Under of machine before improvement.	57
4-9 The result of noise attenuation at front of machine (Left) after improvement.	58

LIST OF TABLES (cont.)

Table	Page
4-10 The result of noise attenuation at front of machine (Middle) after improvement.	60
4-11 The result of noise attenuation at front of machine (Right) after improvement.	61
4-12 The result of noise attenuation at Beside of machine after improvement.	62
4-13 The result of noise attenuation at Rear of machine after improvement.	64
4-14 The result of noise attenuation at Above of machine after improvement.	65
4-15 The result of noise attenuation at Under of machine after improvement.	67
4-16 A comparison of the sound levels results, both before and after an adjustment.	69

LIST OF FIGURES

Figure	Page
2-1 Standardization of measuring instruments	8
2-2 Wavelength in air versus frequency under normal conditions	9
2-3 Interference of sound	11
2-4 Sound meter level type2 Model Casella Series CEL-6X0	18
2-5 Outer Ear	22
2-6 Inner Ear Source: Martin FN	23
2-7 Middle Ear	23
2-8 The pinna and external auditory canal form the outer ear	25
3-1 The measuring results of sound frequency split into octave frequency bands compared with frequency spectrum for OSHA noise problems.	40
A-1 The jewelry cleaning machine.	79
B-1 Noise monitoring layout at cleaning process	80
B-2 Sound meter level type2 Model Casella Series CEL-6X0	80
B-3 Noise monitoring at cleaning box machine.	81
B-4 Noise monitoring at cleaning machine.	81
B-5 Noise monitoring at cleaning machine at front of machine.	82
B-6 Installation absorber material inside of Jewelry cleaning machine.	82
B-7 The monitor point of cleaning machine	83
B-8 Noise monitor at lift of the middle of Jewelry cleaning machine	83
B-9 Noise monitor at middle of Jewelry cleaning machine	84
B-10 Noise monitor at right of the middle of Jewelry cleaning machine	84
B-11 Noise Monitor at beside of Jewelry cleaning machine	85
B-12 Noise Monitor at back of the middle of Jewelry cleaning machine	85
B-13 Noise Monitor at above of Jewelry cleaning machine	86
B-14 Noise Monitor at right of the middle of Jewelry cleaning machine	86

LIST OF FIGURES (cont.)

Figure	Page
C-1 The Comparison result of the before and after improvement the Cleaning jewelry machine that monitor at front of machine	87
C-2 The Comparison result of the before and after improvement the Cleaning jewelry machine that monitor at front of machine (Middle)	87
C-3 The Comparison result of the before and after improvement the Cleaning jewelry machine that monitor at front of machine (Right).	88
C-4 The Comparison result of the before and after improvement the Cleaning jewelry machine that monitor at Beside of machine.	88
C-5 The Comparison result of the before and after improvement the Cleaning jewelry machine that monitor at at Rear of machine.	89
C-6 The Comparison result of the before and after improvement the Cleaning jewelry machine that monitor at Above of machine.	89
C-7 The Comparison result of the before and after improvement the Cleaning jewelry machine that monitor.	90

CHAPTER I

INTRODUCTION

1.1 Background and rationale

The gem and jewelry industry is one of the top ten important export industries of Thailand. In 2533 B.C. (2010 A.D.), the data from census program of the University of Commerce showed that gem and jewelry industry was ranked number five in the country. The same university found that there were 15,777 gem and jewelry factories throughout Thailand. It was developed from small family business into a number of manufacturing for export in order to meet the needs of continually increasing of population, with the result that the development in advance technology were used in the process. There were more equipment, chemical, machinery, and new technology introduced to the process. Such development has resulted in many workers exposed to a wide variety factors that harmful to their health, such as noise, chemical, light heat, and being endanger by using machinery equipment in which it can cause an occupational disease. The gem and jewelry job required a tedious work that in some aspects of the job nature the workers must be right at the machine all the time in which the prolonged exposure to loud noises could cause hearing-impairment, and up to the point of hearing loss later on. Nowadays, the incident of hearing loss from occupation is ranked one of the top ten occupational diseases.¹, and it was found mostly in the United States of America.² In 2538 B.C. the report on current and trend of Thailand's occupational health problems by occupational health department of the Ministry of Public Health stated that there were about 2.32 for every 1,000 people suffered a hearing loss from their occupation each year.³

The results of yearly noise measuring for 2555 B.C. and 2556 B.C. conducted in the workplace area of one gem and jewelry processing and production manufacturing in gemopolis industrial park showed the noise levels above the standard set by the law in which it allows workers to expose to noise for 8 hours during the cleaning process. The measuring results were 91.5 decibels (A) and 92.5 decibels (A),

respectively, which the workers exposed to noise from the machine throughout their work hours. The source of noise was from the jewelry cleaning process, which from 4 locations ; 1). from the impact of hydraulic pressure on the machine. 2). from the operation of the water pump. 3). from the vibration of hydraulic pressure pipe. 4). the reflection of noise from the walls, floor, and the ceiling. In 2556 B.C., there were 5 petitions against the nearby department of its disturbing noises.³

The workers exposing to the loud noise above 85 decibels (A) within 8 work hours will have abnormalities of the hearing or the loss of hearing.¹ The effect of hearing loss on the worker is the communication problems with the family members, community, friends, and colleagues. It brings stress and depression which can cause mental health problem, schizoid, and reduces the quality of life. The deficiency in communication could be open to misinterpretation which could lead to the accident and injury from work⁴, and it could also had the effect on the government in economic loss in which they have to pay compensation for the workers who had the loss of hearing.⁵

The methods used for noise control can be divided into 3 parts, including 1) Engineering control, substitution by lower noise equipment, covering walls or ceiling inside the room with noise absorbent materials, apply noise proof material around the machine and always keep the machine in good condition by checking or repairing it regularly. 2) Administration control, such as rotation of the workers in order to reduce the exposure to the loud noise. Schedule the time to operate the noisy machine. 3) Personal hearing protection, such as using the noise protection equipment and provide training. The loss of hearing symptom of each worker is closely monitored.⁶ Nowadays there is a program to protect the hearing of workers in the workplace required by the law. Engineering control of noise source is the priority and the last defense is hearing protector.

Therefore, an occupational health researcher who has a duty to analyze, examine, and measuring the results in order to determine the process of performing an action pertaining to occupational health and hygiene that promote, control, and prevent an occupational disease. Also perform working practice on health, safety, and environment to comply with the law and the standard. Therefore, a control measure and noise reduction will be taken into account. This can be done by machine

improvement to minimize the risk of harmful loud noise exposure, and then use it as a prototype of machine improvement for an apparent and appropriate engineering design afterward.⁷

1.2 Objectives

1.2.1 To study the noise levels during the cleaning process of the machine.

1.2.2 To compare the noise levels “before” and “after” some adjustment of the jewelry cleaning machine

1.3 Hypotheses

The noise at every measuring point “before” and “after” is significantly different. (p-value < 0.05)

1.4 Variables

1.4.1 Independent variable is Noise absorbent materials installation.

1.4.2 Dependent variable is Noise levels.

1.5 Conceptual Framework

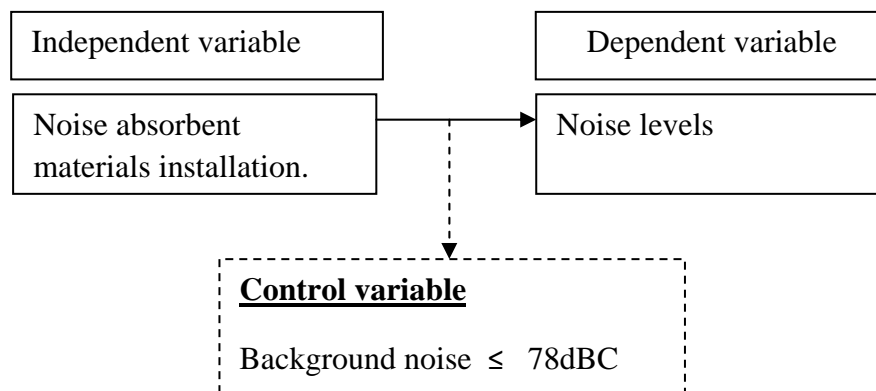

1.6 Definition Terminology

1.6.1 Noise absorbent materials installation refers to Super Silences which is the absorbent material with 25 mm thick, which was installed for 7 sides inside the spray wash machine at hydraulic pressure of 150 Psi.

1.6.2 Screen off around the hole where both hands can place inside to spray washing the jewelry piece represented an installation of noise absorbent material, 6 cm wide and 8 cm long, inside the jewelry cleaning machine in order to screen off the hole which for putting the hands inside the spray wash machine.

1.6.3 The noise level refer to the measuring results of noise occurring during the washing process after some adjustment to 7 points on the jewelry cleaning machine at the levels of Scale A, Scale C, Octave weighting C at 100 Hz, 125 Hz, 160 Hz, 200 Hz, 250 Hz, 315 Hz, 400 Hz, 500 Hz, 630 Hz, 800 Hz, 1,000 Hz, 1,250 Hz, 1,600 Hz, 2,000 Hz, 2500 Hz, 3,150 Hz, 4,000 Hz, and 5,000 Hz.

1.6.4 The jewelry cleaning machine refers to trapezoid stainless box with 1.2 mm thick, 54 cm wide, 110 cm long and 110 cm high. There are 2 holes in the front to place the hands inside. There is also a hydraulic pressure pipe of 150 Psi inside the jewelry cleaning machine.

1.6.5. The noise absorbent material refers to material designed to absorb noise made from Elastomeric foam based on synthetic rubber (SUPER SILENCE); the density is 140 kg/m³ the thickness is 50 mm, Elongation 40%, Tensile strength 60-90 kPa, and Thermal conductivity 0.047 w/ (m-K).

1.6.6 Background noise: Noise from various sources in the environment that is unrelated to the particular noise of interest.

1.6.7 Leq: equivalent noise level, the constant level which would have the same energy as the time-varying level over equal sampling period.

1.7 Scope of the study

The objective of this study is to compare the noise levels from the process of jewelry cleaning machine.

1.7.1 The study working area is a rectangle room with the volume of 369.6 cubic meters (6 meters wide x 15.4 meters long x 4 meters high).

1.7.2 The jewelry cleaning machine in the experiment is in an actual working area. There are 2 hot-air blowers, 1 nozzle spray wash equipment. The 15 jewelry cleaning machines are made of 1.2 mm stainless thickness. The male plug underneath is a 0.9 mm stainless thickness. There is an improvement to the machine by installing noise absorbent material 6 sides inside the machine.

1.7.3 The motor of spray wash machine use hydraulic pressure levels of 150 Psi. It is installed away from the spray wash machine about 800 centimeters, and there is a 10 centimeters concrete wall separating between them in the middle.

1.7.4 The installation of a 25 mm thick, Super Silence, an insulated material to reduce the noise inside the jewelry cleaning machine 6 sides, including the top, the bottom, the left side, the right side, the front, and the back.

1.7.5 The level of noise are of Scale A, Scale C, Octave weighting C at 100 Hz, 125 Hz, 160 Hz, 200 Hz, 250 Hz, 315 Hz, 400 Hz, 500 Hz, 630 Hz, 800 Hz, 1,000 Hz, 1250 Hz, 1,600 Hz, 2,000 Hz, 2,500 Hz, 3,150 Hz, 4,000 Hz, and 5,000 Hz.

1.7.6 The measurement positions of the noise level of noise are as the following;

1.7.6.1 The leq 5 minute the noise levels the front of the machine in the working area. There are 3 kinds of equipment, including nozzle cleaning equipment, hot-air blowers, and immersion equipment for the jewelry. The measurement of the average noise levels at the distance of 60 centimeters away and 159 centimeters above the floor.

1.7.6.2 Measures the noise levels “before” and “after” at the modified jewelry cleaning machine, 6 points, including at the hole in the front for left hand to go through, the middle of the front of machine, the hole in the front for right hand to go through; the measuring point on the side of the machine, on the back, and on the top of the machine. The measurement of the average noise levels at the distance of 60 centimeters away and 159 centimeters above the floor at Leq 5 minutes

1.7.6.3 Measures the noise levels “before” and “after” some adjustment on one point underneath the jewelry cleaning machine at the distance of 60 centimeters away and 30 centimeters above the floor with the measurement of average noise levels of Leq 5 minutes, and measures 5 times for each point.

1.7.6.4 Measures the noise levels “before” and “after” some adjustment of the jewelry cleaning machine at the hydraulic pressure of 150 Psi.

1.7.6.5 Measures the background noise levels at the middle of the room of the spray wash department during a downtime.

1.8 Limitations

1.8.1 Due to the cleaning machine was installed in a working area, the reflection of noise may occurred from cleaning or other equipment.

1.8.2 The expirement can not done in the labotaly because of the budget and the company did not allow to move the cleaning machine out of company.

1.9 Expectation of the benefits

1.9.1 Guidance for studying in the noise levels in the workplace area.

1.9.2 Principles for machine improvement to reduce the noise, and can be used as a criterion or can be applied to others similar equipment.

CHAPTER II

LITERATURE REVIEW

2.1 Basic of Sound

2.1.1 Component of Sound wave Sound wave composed of three components⁶

1) *Frequency*; is the rate at which a sound wave vibrates. The number of cycles per second is expressed in Hertz (Hz). It is equivalent to cycles per second.

2) *Amplitude*; is the amount of a force of an air pressure moved by a point on a continually vibrating body measured from its equilibrium position. Pascal (Pa) is a pressure measurement unit.

3) *Phase*; is a definition of the position of a point in time on a waveform cycle. A complete cycle is defined as 360 degrees.

2.1.2 Characteristics of Sound^{6,9,10,11,12}

1) *Sound* is the movement of energy through compressible mediums such as a solid, liquid, or gas molecules. The sound waves move through each of these mediums by vibrating the molecules in the matter. Air particles moves in a to and fro position where they collide with each other to form a compression and rarefaction that caused the vibration

2) *Sound Wave* is the pressure deviation from the equilibrium atmospheric pressure there are regions in the air where the air particles are compressed together and other regions where the air particles are spread apart. These regions are known as compressions and rarefactions. The compressions are regions of high air pressure while the rarefactions are regions of low air pressure as shown in Figure 2-1.

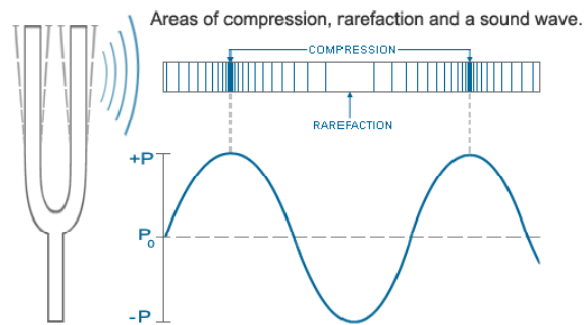

Figure 2-1 Representation of a sound wave.

Human ear can response to the sound wave traveling through air which cause a rapid pressure variation in the air. When the vibrating air reaches the ear, the eardrums then transmit these vibrations to a nerve impulse that is transmitted to the brain.

Sound waves are divided into three different frequency ranges, including

- 1) Frequencies between 20 to 20,000 cycles per second, known as the Audible Waves. It is the general range of hearing for human ear.
- 2) Frequencies below 20 cycles per second, known as Infrasonic Waves.
- 3) Frequencies above 20,000 cycles per second, known as Ultra sonic Waves.

Sound waves can travel through all states of matter, but they do not travel the same way through each of these different substances. The distance between the particles affects how strong the interactions are between them. This, in turn, affects how quickly they transfer the energy of the wave. The stronger the particle interactions are, the more quickly the wave is transferred. Thus, sound travels faster in solids than in liquids, and faster in liquids than in gas. The constant temperature at a given point also has the effect on the speed of sound too.

The equation 1 below is known as the wave equation. It states the mathematical relationship between the speed (**c**) of a wave and its wavelength (**λ**) and frequency (**f**).

Using the symbols **c**, **λ**, and **f**, the equation can be rewritten as

$$\text{Verocity (C)} = \text{wavelength } (\lambda) * \text{frequency (f)}$$

3) *Speed of Sound*

It is the rate in which the motion of the wave pressure that moves from its source through the air. The units are metres per second. The rate of sound speed will be changed to comply with the square root of absolute temperature (Kelvin, T in K) of the medium as shown in equation 2, as follows.

$$C \propto T$$

4) *Frequency of Sound*

It refers to a cycle of sound wave that moves through the air in 1 second or the number of each time that air pressure changed according to the compress and decompress of air molecules in 1 second. Their units are cycles per second or Hertz (Hz); in which it can be plotted on the graph that illustrated between amplitude and time, or amplitude and the distance.

5) *Wavelength of Sound*

It is the distance in which sound travels to complete 1 cycle. It can be expressed in with Lamda (from a Greek word meaning “wavelength”). The basic unit is metre. Sound wave is very important to the study of noise control as shown in Figure 2-2.

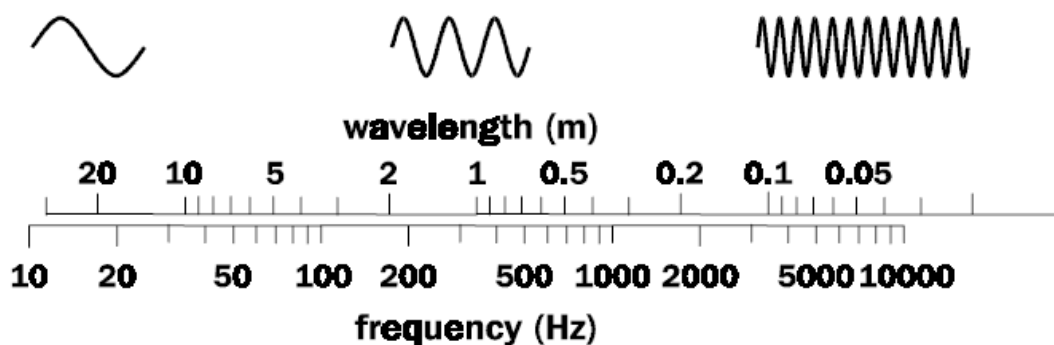

Figure 2-2 Wavelength in air versus frequency under normal conditions.

6) Period

It refers to the time required for one complete cycle of a wave to pass a given point. The units of period are seconds/cycle. The relationship of the period is said to be reciprocal of the frequency. This can be expressed in equation form, as follows

$$T = 1/f$$

7) Diffusion of sound wave

It occurs when a sound travels through some opening or porous material (*Diffusion*), such as wall panelings or the obstacles. If the diameter of such porous material is smaller than a sound wave, the sound will find its way through the pores, and it will cause the sound energy to be radiated in many directions which depletes its energy faster so that it looks like a sound that come from new source. If the opening is larger than a sound wave, the sound will travel through the pores without the depletion of its energy of the wave.

8) Refraction of Sound

A sound wave travels from a source through different medium bodies. Depending on the mass density of the mediums, sound propagates at different speeds and direction. Based on Snell's law, these phenomena called law of refraction. The different in a sound wave speed depends upon the properties of the medium through which the wave is moving. Only an alteration in the properties of the medium will cause a change in the speed, such as the temperature, the humidity, the direction, and the speed

9) Reflection of sound

When a sound wave traveling from a source and strikes a medium that has flat, rigid surface, or the area that has an alteration in the properties of the medium rapidly, it will be reflected. These phenomena called law of reflection. Reflection occurs better if a sound strikes on flat, rigid surface with a lot of mass that larger than the wavelength, and that does not have an absorbent properties.

10) Diffraction of sound

It occurs from the change of the direction of sound waves when it strike the obstacles, the sound waves bend around the obstacles. In such case, we can hear sound around corners of the building. Diffraction of sound differs from the refraction of sound and the reflection of sound since it occurs on the same mediums.

11) Interference of sound

Sound waves from more than two sources meet at the same location while traveling along the same medium will interfere with each other. According to the principle of the combining waves from more than two sources and the two waves have a slight difference in the frequencies, the interference is said to be constructive interference. Such interference of sound waves causes particles of the medium to behave in a manner that reflects the net effect of the two individual waves upon the particles, and produce a louder sound than usual. Sometimes the two pulses will cancel out each other effects and produce a softer sound or no sound is heard at all. This type of interference is known as destructive interference. When two sound waves of different frequency are brought closer together, the alternating constructive and destructive interference causes the sound to be alternative soft and loud, such phenomena called “beats” The loudness of the sound is the result of the amplitudes of the two waves undergoing oscillations from very high (producing loudness sound) to very low (producing softness sound) pressure.

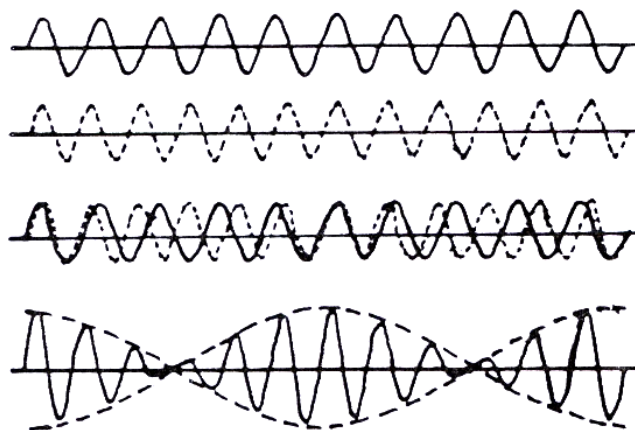

Figure 2-3 Interference of sound .

12) Doppler Effect

When the observer and the source of the sound are in relative motion to each other, as the source approaches the observer, the perceived pitch and frequency are higher than when it is stationary. As the source and the observer move apart, the perceived pitch is lower. The change in pitch and frequency of sound heard by listener is called “Doppler Effect”

13) Resonance

When an object is stimulated by an outside force of the same frequency, it vibrates at its natural frequency. If the frequency of the outside force closely approaches that of the object, the oscillation of an object reaches maximum amplitude at the natural resonant frequency.

14) Types of sound

There are three main types of sounds

1) Pure tone consists of a specific constant pitch of a single frequency and not found in nature such as a tuning fork, the sound of violin, etc.

2) Complex tone consists of harmonious combination of frequencies components, such as musical sound, voice in the form of a speech, or voice in the form of a song, etc.

3) Noise consists of many frequencies without rhythm, or having a regular pattern of many sounds that disturb people and make it difficult to hear. This disturbing noise could be from a pure or a complex tone, such as a machinery noise, road traffic noise, etc. If people that in continuous heard this kind of noise for a long period of time, they could have hearing impair. There are two types of noises.

3.1) Continuous noise. A continuation of noise without interruption in the same mode, The noise may be fluctuated between high and low pitch, including

- Steady- state noise or continuous noise.
- A continuous noise that the level of which does not change by more than 5dB in one second, such as the sound of air conditioner, the sound of loom machine, etc.

- Fluctuating noise is the level of which it changes by more than 5dB in one second. The noise can be measured just as for continuous noise, such as siren sound, the sound of an electric chainsaw, etc.

- Intermittent noise. The noise level is increase and decrease rapidly, usually is intermittent such as traffic noises, a passing aero planes, etc.

3.2) Transient noise consists of a relatively short pulse followed by decaying low frequency oscillations, including

- Impulse noise is the noise from impacts or explosion in the area where there is no reflecting of sound, such as the sound of gunshot in an open area, the sound of a pile driver at the construction work, etc.

- Impact noise is the sound produced by the collision of two solid objects in the area that the sound can be reflected back, such as the sound of gunshot inside a room, the sound of hammering the sheet of iron.

2.2 Sound measurement

The measurement related to this research is to measure the level of noises from the operating machine in which the researcher had a review of documents that related to the research,^{1, 9, 12, 13, 14, 15}

2.2.1 Preparation for the sound measuring consists of an initial survey in order to find and to study about the sound level that may be harmful, and set an appropriate area and layout for the work. Study about production processing, types of machines in the working area,

2.2.2 Preparation for the appropriate sound measuring instruments, by using a suitable instruments for the objective measure, check their condition for the availability of use. Studying for the standardization of taking a sample and the process of recording method. The instruments use in sound measuring is the sound frequency analysis in which can be used to analyze the dispersal of sound energy in difference frequencies. The instrument can detect the sound loss which occurs when the high frequency interferes with the low. Thus, the loss of hearing in high frequency is greater than in the low.

2.2.2.1 Sound measuring tools and instruments

1) Sound level meter. It can measure the level of sound waves, ranging from 40dB to 140 dB, which be able to measure 3 weighting networks A, B, and C. In a lawful workplace environment, the instrument that used for measuring the level of the sound must meet the standardization of IEC 651 type2 (International Electro technical Commission 651 Type2) or equivalent to ANIS S. 1.4, BS EN 60651, AS/NZS 1259.1, etc.

2) Impulse or Impact Noise Meter is suitable for measuring an impulse or impact noise that occurs in a brief period of time, and then disappear in which no any other instruments response to the impact noise fast enough. The instrument must have a characteristic that comply with the standardization of IEC 61672 or IEC 60804 or equivalent to, such as ANSI S 1.43 or better

3) Noise Dosimeter has the ability to record a total sound level that a worker is exposed to, then calculated an average noise exposure during a complete whole work shift. The characteristic of the measuring instrument comply with the standardization of IEC 61252 or equivalent to, such as ANSI S 1.25 or better.

4) Frequency Analysis can tell the loudness of the sound at different frequencies, and the measuring results can be useful for noise level control planning, such as choosing the absorbent material, sound screen, and an appropriate ear protection too. Generally, the measuring instrument must have the characteristic that comply with the standardization of IEC 61260 or equivalent to, such as ANSI 1.1 or better.

5) Sound measuring apparatus

Noise Calibrator is used for checking the accuracy of the sound. Some adjustment before using it may be necessary. By either using piston-phone or oscillator-type to ensure high stability of the pure tone intensity as the instruction given. The measuring instrument can then be adjusted until it indicates the correct sound level pressure. Calibration must be performed immediately, both before and after each use. It must have the characteristic that comply with the standardization of IEC 60942 or equivalent to, or better.

Wind Screen. In measuring the sound level pressure, strong wind may cause the reading of the sound measuring instrument to be inaccurate.

When measures sound levels in an area where the fan is on, a wind screen must be put on the microphone every time and all the time while the measuring instrument is operated. It can prevent dust, vaporous oil, or any other chemical substances from damaging to the microphone of the measuring instrument.

Tripod is a support with three legs. It is used for supporting a large sound level measuring instrument, or to be used when it takes long period of time to each measuring post. It helps to reduce problems that caused by the body of the worker blocked the sound or reflect the sound back to the microphone.

2.2.2.2 Sound level meter components

The sound level meter consists of 5 parts as follows

1) Omnidirectional microphone. Its duty is to response to the sound level pressure and creates electronic signals.

2) Weighting networks control the response to the different frequency of the sound levels pressure. Today's, there are 4 types of weighting networks, the A, B, C, and D. A weighting is the most commonly used for measuring dangerous noise levels, since it can response to the loudness of the different frequencies in which it is perceived by human ears. Weighting networks B and C are used for industrial machinery. Weighting D designed for used when need to measure extremely highly noise levels, and the noise interference.

3) Amplifier has the ability to amplify frequency in the range of 20-20,000 Hz. Because of the frequency in which it needed to be analyzed falls between 50-6,000 Hz. Moreover, the interfering noise from the amplifier which is called "electronic noise" must be low too.

4) Attenuator. Sometimes the sound levels that are highly different from one another needed to be measured. Thus the power of these different signals can be reduced by the used of attenuator.

5) Meter. Its duty is to display the loudness of sound levels obtained. With the time weighting device in which it offers a choice of meter response according to the characteristic of noises that occurs in a function of time, including

Slow (S) is used for the measurement of steady-state noise. The characteristic of the sound intensity is rather constant, the level of which will change by not more than 5dB in one second. The meter will response and reading out for every 1 second (1,000 millisecond, or has the average integration time = 1 second).

Fast (F) is used for the measurement of fluctuating noise in which the meter will response rapidly and read-out every 1/8 second (125 millisecond).

Impulse (I) is used for the measurement of impact noise in which the meter will response and read-out every 1/30 second (35 milliseconds).

Peak sound pressure level (P) is used for the measurement of the maximum value of the peak sound level of an impact noise in which peak is the true maximum of sound pressure level over a period of a measuring time. Do not use weighting network (must choose Linear only)

L_{max} (Maximum) is the value of the sound pressure level type root mean square that is the maximum value of the sound pressure level over a period of a measuring time (by using time weight slow, fast, or impulse)

L_{min} (Minimum) is the value of the sound pressure level type root mean square. There is the minimum value of the sound pressure level over a period of measuring time (by choosing time weight slow, fast, or impulse).

2.2.2.3 The Function of Sound Level Meter

When sound waves hits the microphone's diaphragm, the vibration of diaphragm caused the microphone to turn the pressure into potential difference in which they were increased by preamplifier and then passed through weighting networks in order to adjust the signal current into spectrum that account for the relative loudness perceived by the human ear. The signal will pass through the amplifier one more time for the voltage meter to give a logarithmic readout in decibels²⁵ There is a wide variety of instruments and apparatuses used for measuring the sound level, thus, it is better to choose the right type that appropriate to the characteristic of the sound needed to evaluate.

Type of Sound Level Meter in which American National Standard Institute, ANSI or IEC (International Electrotechnical Commission) specifies the standardization of every type of sound level meter as follows

Table 2-1 Standardization of measuring instruments

Instruments	(Accuracy)	
	IEC651	ANSI SI.4 - 1983
Type 0 (Laboratory standard type)	± 0.4 dB	± 0.4 dB
Type 1 (Precision type)	± 0.7 dB	± 0.7 dB
Type 2 (General purpose type)	± 1.0 dB	± 1.0 dB
Type 3 (Survey type)	± 1.5 dB	
Type 4 (Special purpose type)		

2.2.2.4 Preparation for the appropriate instruments

The researcher chooses frequency segments sound level measuring Type 2 Model Casella Series CEL-6X0 Calibration on 15 December 2013. It was an instrument used for measuring the interference of sound waves, SPL and Octave band model, in which comply with the standard and the specification, that is IEC 61672-1 2002-5 (Electro-Acoustics–Sound Level Meters) Group ‘X’ instruments. Performance of Class 1, or 2 as relevant to instrument model. IEC 60651: 1979, IEC 60804: 2000, ANSI S 1.4: 1983, ANSI SI.

Octave Filters comply with EN 61210: 1996, Class 0 and ANS 1.11 1986, Order 3 Type 0C., in which consisted of 1 – Windshield (Covering removable microphone), 2 – Fixed Preamplifier, 3 – ON/OFF Key



Figure 2-4 Sound meter level type2 Model Casella Series CEL-6X0

2.2.3 Factors affected the function of sound measuring instrument.

Sound level instrument consists of electrical system; therefore it's sensitive to the environmental impacted, especially on the microphone. Thus, careful consideration should be given to the issue of sound level measuring^{16, 17, 18}

2.2.3.1 The temperature of sound level instrument was built for use in normal temperature. The appropriate temperature is mostly fall between -7 to 66 degree Celsius, by adjusting it to room temperature. Thus in a case of the temperature is higher or lower than this, it would be better to adjust it to the appropriate temperature. Also, should study for detail in the manual for accuracy and reliability.

2.3.3.2 The humidity of sound level measuring that passed the inspection by OSHA (Occupational Safety and Health Administration) can be used in high humidity place except the humidity that condensed into drops of water on the microphone in which it has relative humidity at 65%.

2.3.3.3 Barometric Pressure will effect on the sound from noise calibrator. It needs to be adjusted according to the recommendation of the manufacturer. Generally, if the area used for measuring the sound level is not more than 10,000 feet above the sea level, the effect of barometric pressure on sound is very low, thus it needs not to adjust the calibrator. If the area is 10,000 feet above the sea level or if the area is higher than normal barometric pressure, then it need to be adjusted for the accurate measurement.

2.3.3.4 Wind blows causes loud noise and interferes with the accuracy of the measure in which it will cause the readout to display the value higher than the fact. Thus, the microphone should be covered with wind screen before measuring the sound level.

2.3.3.5 Electromagnetic field and vibration will effect on the extension cable microphone rather too much that it may damage the measuring instrument. In the case of the sound that is louder than 120 dB, the sound waves may cause the microphone’s structure and the components of the microphone to vibrate. The microphone should be set outside loud noise area by using an appropriate extension cord that does not allow the vibration within the wire create noise.

2.3.3.6 Background noise. Things that need to be taken while measuring the sound level, are, background noise, humidity, wind, or electrical signal. It is important to set a background noise level when measuring the ground level. From the study, when background noise level has the value in each of the frequencies more than 10dB, the level from background will have no effect on the significant for the measuring, as a result, it needs not to adjust measuring level. In a case of the result from background noise level measuring has the differential value less than 3dB, it will have an effect on the accuracy of sound level measuring study. In a case of the measuring result has the differential value between 3 to 10 dB, There is a need to adjust the result value obtained from the measuring as shown in Table 2-2

Table 2-2 Correction for background noise contribution in sound measurements

If the total noise exceeds the background noise by	Then the operation noise alone is obtained from the total noise by subtracting
3 dB	3 dB
4 to 5 dB	2 dB
6 to 9 dB	1 dB

2.3 Analysis and Assessment

In measuring of noise in the workplace environment prefer to sound level meter to measure the sound at an area or at the post where the worker is working. The instrument was set with readout in average values of the loudness level that the worker exposed to throughout the work shift (Equivalent continuous sound level, Leq). The unit is dB (A), then compare with the standardization^{18, 19, 20}

Standard level of sound are designated by American Conference of Governmental industrial Hygienist (ACGIH), which specifies levels of continuous sound and level of intermittent sound as shown in Table 2-3

Table 2-3 Specifies levels of continuous sound and level of intermittent sound.

Sound exposure per day (hrs)	Sound level dB(A)
16	80
8	85
4	90
2	95
1	100
½	105
1/8	115

Note: Both continuous sound and intermittent sound cannot be louder than 115dB (A)

The standardization of sound stipulated by OSHA³⁰ determine a period of time that allowed to exposed to each sound levels as shown in Table 2-4

Table 2-4 The standardization of sound stipulated by OSHA

sound stipulated (Hrs)	Sound level dB(A)
8	90
6	92
4	95
3	97
2	100
1.5	102
1	105
0.5	110
0.25 or less	115

Ministerial regulation determines the standardization in administration and management in occupational health and workplace environment related to heat light and sound 2549 B.C. as shown in Table 2-5

Table 2-5 The standardization of sound stipulated of the day.

sound stipulated (Hrs)	Sound level dB(A)
12	87
8	90
7	91
6	92
5	93
4	95
3	97
2	100
1	105
0.5	110
0 _≥ .25	115

2.4 The effect of sound on health

2.4.1 Anatomy of the ears.

The ear is the sensory organ that produces a sense of hearing and also produces the body's sense of the equilibrium. The ears can be divided into 3 parts; the outer ear, middle ear, and inner ear. These three parts locates underneath the temporal bone which is at the side of the head.^{6, 18, 19, 20}

2.4.1.1 External ear consists of 3 parts, the visible outer ear called pinna or auricle, the ear canal, and the outer of the tympanic membrane known as eardrum. The outer ear helps to focus a sound. Sound that travel through the outer ear impact on the tympanic membrane and causes it to vibrate. The ear canal consists of an inner portion surrounded by bone, and outer portion surrounded by cartilage. The auricle is the flexible organ whose curves help to conduct sounds. In the center of the auricle is the external auditory canal which is a tube that conducts sound through the body exterior and skull to the eardrum, and through the middle ear as shown in figure 2-5

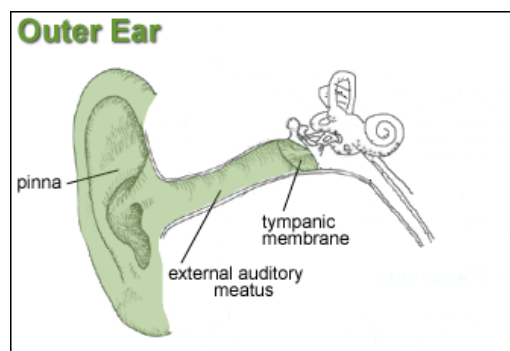

Figure 2-5 Outer Ear

2.4.1.2 Middle ear is a cavity called tympanic cavity or tympanum, behind the tympanic membrane, including three bones known as the ossicular chain: the malleus (or hammer), incus (or anvil), and stapes(or stirrup) as shown in figure 2-5. The tympanic cavity is hollow mucosa-lined cavity in the skull that is ventilated through the nose. The eustacchain tube that connects the middle ear to the back of the nose (nasopharynx); it equalizes the pressure between middle ear and the air outside.

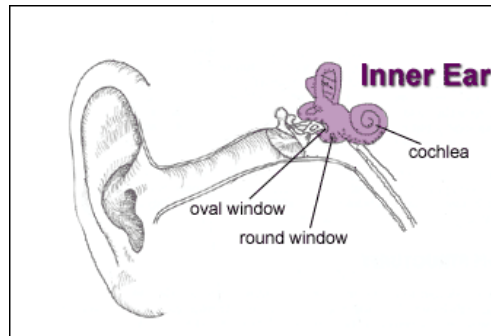

Figure 2-6 Inner Ear Source: Martin FN.

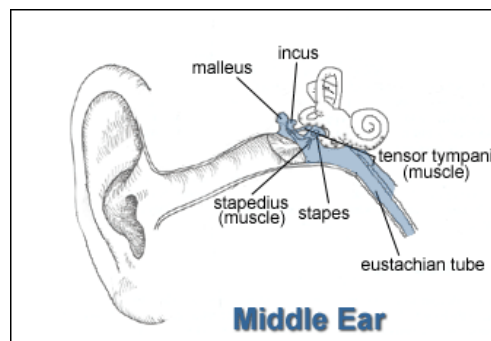

Figure 2-7 Middle Ear

2.4.1.3 Inner ear or labyrinth consists of two components; the sensory organ for hearing, the cochlea portion, and, the sensory organs for balance, called the vestibula portion. The cochlea consists of three fluid-filled spaces, including the scala tympani, the scala vestibuli, and the scala media, all of are responsible for hearing. The cochlea is the spiral shaped fluid-filled inner ear structure. It is lined with tiny hairs that move when vibrated and cause a nerve impulse to form. Nerve fibers between scala media and scala vestibule called vestibula membrane or reissner's membrane, and, nerve fibers between scala tympani and scala vestibule called basilar membrane. Inside the scala media tube contain fluid called endolymphatic fluid, and, the organ that responsible for hearing, called organ of corti, in which it laid on top of the basilar membrane, that is studded with hair cells. Each hair cell is connected to a gel like called tectorial membrane. The movement of this membrane caused the cell to create an action that is transmitted along the spiral

ganglion, which sends information through the auditor portion of the acoustic nerve to the temporal lobe of the brain where it is register as sound.

2.4.2 Hearing

Sound waves travel through the outer ear, and modulated by the middle ear, and, transmitted to the middle ear. When the sound was reached the ear canal, it will be amplified by the ear canal up to about 5-10dB (A). The sound that travel through the outer ear impacts on the eardrum and causes it to vibrate, which in turn causes movement of the malleus, which causes movement of the incus which causes movement of the stapes. These 3 pieces bones are fully functional when the sound frequency is more than 600 Hz. When the stapes pushed on the oval window, it causes movement of the perilymphatic fluid within the scala vestibuli and tympani, in which it causes the sound pressure to decrease by 30dB (A). The tympanic membrane acts like a microphone by converting the sound waves into movement of the membrane. Hair cells that are connected to a neuron at the low-end of the cochlea will do best receiving high frequency, and, hair cells at the high-end of the cochlea do best receiving low frequency. The hair cells release a chemical neurotransmitter when stimulated and formed nerve impulse which sends information through the auditory nerve via nerve fiber to the brain where it is registered as sound.

Sound waves are transmitted to the inner ear by 2 ways.

By air conduction (AC); Sound waves travel through the outer ear, and modulated by the middle ear, and are transmitted to the inner ear.

By bone conduction (BC); Sound waves travel through mastoid bone in which it located at the back of the ear, and transmitted to the cochlea in the inner ear as shown in figure 2-8.

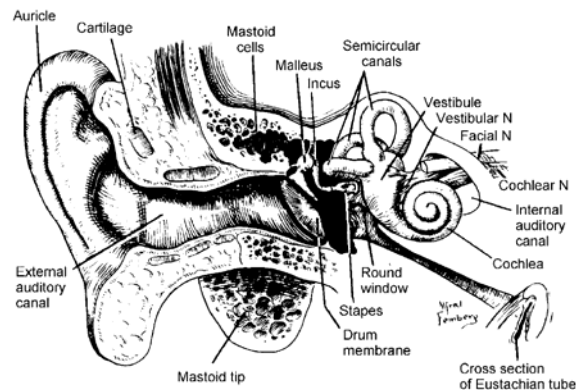

Figure 2-8 The pinna and external auditory canal form the outer ear.

2.4.3 The sense of hearing

Human ear can generally hear sounds with the frequencies between 20 – 20,000 Hz. The younger they are the better they can hear. When they get older, the ability to perceive high pitch will be reducing in proportion to their ages. The normal frequency in daily life is between 125 – 800 Hz, but the frequency of speech is between 500 – 2,000 Hz.

2.4.4 The level of hearing

The ordinary of human ear can hear the sound frequency that is not greater than 25dB... Therefore the classification of hearing level is based on the intensity of sound level within the range of 500-2,000 Hz. According to Boorri Jantoh, “hard of hearing, begins begins when hearing the sound levels between 25-90dB. Deaf, begins when hearing the sound that is more than 90dB”

2.4.5 Hearing impaired

The sound that is more than 85dB (A) will affect the different parts of the human body. In addition to this, the sound level that is less than 85dB (A) can interfere the conversation, dictation, and communication, including concentration on the work. The health industry divided the sound levels that are potentially hazardous to human health into 2 kinds.

2.4.5.1 The effect of sound on health. Loud noise can cause conductive hearing loss, in which it can be divide into 3 types, as follows.

Acoustic trauma

It occurs when the ear exposed to an extremely loud noise in a short period of time, or a sudden burst of loud noise at once, such as a bomb goes off, the sound of gunshot out louder than 130dB(A). The acoustic trauma was causes by a torn eardrum, the three bones are sprits apart, or the hair cells were destroyed.

Temporary threshold shift (TTS)

It occurs when the ear exposed to the loud noise for quite a while, then return to the recovered period. This type of hearing loss can resume to normal condition after expose to the noise, the recovery period may take as much time because it is equal to the time of hearing the noise, and it depends on the level of the noise that the ear exposed to.

Permanent Threshold Shift (PTS)

It occurs when the ear exposed to the loud noise continuously for a long period of time. This type of hearing loss is permanent in which it cannot return to normal conditions after the exposure. It cannot be cured.

2.4.5.2 The effect of noise on health in which the worker exposed to, including

- Shrinkage at the terminal of the red blood vessel the more loud noise increases, the more shrinkage of red blood vessel increase, especially along the arms and the legs. Therefore, the heart will work harder, and, it can cause the increasing in the heart rate and the blood pressure.

- Increasing in some hormone level such as thyroxin, and corticosteroids.

- Decreasing in breathing rate, and saliva, and digestive enzymes and caused digestive system cannot function properly.

- The system of muscle works harder in which it can caused pulled muscle, twitch muscles

2.4.5.3 The effect of noise on human emotion as follows

- Irritation. High frequency irritates more than low frequency.

- Lack of concentration.

- Insomnia.

2.4.5.4 The effect of noise on the work.

- Loud noise can cause an accident, and reduced the efficiency on the job.

- Individual behavior effect, such as slow response. Loud noise have the effect on mind and emotion, thus it can causes workers make mistake on their job.

- Loud noise can keep a person from thinking the thought clearly.

- Noise that have an effect on the work, including, intermittent noise, noise that is higher than 2,000Hz. Repeatedly loud noise, and mixed noise as mentioned above.

- Loud noise interfere switch communication. Noise level of 70 dB (A) can interferes. with the phone wires. Loud noise makes worker cannot hear the abnormal sound from a running machine. Two people standing only at 1 arm's length apart still cannot communicate to each other.

- Cannot hear warning sound of the siren.¹²

2.5 Noise control basic concepts terms

2.5.1 Engineering noise control

2.5.1.1 Regular maintenance helps prevent problems caused by the machine. Checking the leakage in the steam engine. Look for damaged gear, slapping belts that does not set properly, it can cause imbalance in the engine. Check and make that there was enough grease for machine's parts.^{11, 12}

2.5.1.2 Installing the machine in an open area, such as outside the building. The level of sound will decrease 6dB for every distance from the source twice.

2.5.1.3 Vibration control. In order to reduce the vibration of the running machine, it can be done by using insulating materials to isolate the machine away from any others. Another way is to keep the engine maintains a good

balance. Reducing the contact of the machine's part by forming a group units of their own that do not joined with other group units.

2.5.1.4 Use silencers to reduce the amount of noise that the engine makes. Especially the exhaust pipe.

2.5.1.5 Reducing the impact noise caused by machine's part touch one another.

2.5.2 Noise control management

Set the policy to prevent loud noises caused by the machine. The chair person will determine the policies, from choosing to buying quite machine. This is a very effective way in technical noise controlling.^{11, 12}

2.5.3 Noise Control Pass

Technical noise control using an engineering method, including

2.5.3.1 Shields and Barriers. It is a solid material that put between the worker and the source of the sound. It controls by reflecting back.

2.5.3.2 Enclosures, there are 3 topes of enclosures as follows.

1) Partial enclosure is a way of using shields and barriers to cover around the machine except the top part of the machine in which the noise may escape from the machine top, travel through the air and hit the ceiling, then become an echo. Another way is let workers walk into their work station this method allows the noise to emerge from the confined area. It can reduce sound to about 12-15 dB.

2) Total enclosures can reduce the sound more than 12-15 decibels. One problem is that the heat within the confined area is unbearable. Therefore, ventilation need to be installed, also a walkway for the worker. The sound can escape from the holes. Do not let the shield and barrier touch the machine. The vibration barrier should be installed between barriers and the floor.

3) Wrapping/ Lagging, In a case source of a sound is a pipe or hoppers. Noise control can be done by wrapping or lagging. By using a sound absorbent materials to cover the vibration surface area, then put impervious material on top, such as metal sheet flexible mass-loaded vinyl. This method reduced sound

level up to 20dB. In wrapping the radiating surface, it can be done with 2 layers. The inner one is a resilient layer such as glass fiber about 1 - 4 inches thick. The outer layer is an air tight heavy layer.

2.5.3.3 The installation of sound absorbent material, Technically, by using the shields and barriers together with the sound absorbent material will help control the noise more effectively.

2.5.4 Noise control on the worker part

2.5.4.1 By using the engineering method, if the worker have to sit working in a very loud noise area, and the sound does not come from their work at all. Therefore, in this case, an office should be built for them.

2.5.4.2 By using the management method

1) Job rotation. This technique can be used in a very loud place. The exposure to the noise is only for a short period of times. If the worker is not very loud, the exposure time can be extend for a longer period of time. The relationship between the exposure times allowed (T) and the loudness of the sound levels (L). In equation form, this is expressed as follows

$$T = \frac{8}{2(L-80)/5}$$

2) Hearing protection device, The popular hearing protection device is the ear plug and ear muff. The noise attenuation in each device is different, thus the noise reduction rate (NRR) needs to be taken into consideration

2.5.5 Noise control measures

2.5.5.1 Sound absorption is the sum of the change in the sound energy that reduced when it moved through any kind of the medium bodies. It is the ability of the materials to absorb the sound energy, and then transfer into heat energy. The materials with good sound waves absorption are fibrous and porous. When sound waves hit those materials, a portion of the waves are absorbed into them, however, it depends on the property and quality of each material.^{11, 12} Sound absorption coefficient

is the indicator to the efficiency of sound absorption in each kind of materials. When the sound waves moved through the material, their energy will be reduced because a portion of them was transfer to the heat energy.

The compositions that have an effect on the absorption of materials are the thickness, density, and porosity, flow impedance, coefficient of elasticity, and acoustic impedance ^{6, 11, 12} Sound absorbent materials can be divided into 3 types, according to their mechanism, as follows

1) Membrane absorber, such as a thin metal sheet, plywood, plastic, gypsum board, etc. Their vibration has the same frequency as the sound frequency, when hits the materials since these materials do not have absolute elasticity. Thus, some energy loss can be expected because of the energy transfers, the sound energy then transfers to heat energy. The materials can absorb more sound at low frequency because the membrane moves better in low frequency than in a high frequency. High frequency of the sound waves, once hits the membrane, it will reflect back to the source where it came from. Therefore, the loss of energy is lesser than the loss of energy in low frequency.

2) Resonator or cavity absorber

The structure of each cell is called “sound box”. If the diameter of the cavity is smaller than the waves that hits right at the opening holes, then the resonator will make an adjustment for the frequency in which it causes the vibration of the air volume, as it moves through the opening holes. The materials can absorb the sound waves better at the frequency that lower than 1,000 Hz. and do best at 100 – 300Hz. and, its efficiency will decrease when the frequency is higher. However, when put other absorbent materials such as fiber glass into the sound box, it will increase the ability to absorb at the frequency with a wider range.

3) Fiber, porous, or dissipative absorber

These types of materials are inexpensive and easy to find. In Thailand, there are plenty of agricultural products such as corn husk, rice husk, sugarcane bagasse, and straw. These types of materials, their cavity has a diameter less than 1 millimeter in which it was less than the wavelength, thus these materials are the medium that caused the energy loss better because the vibration frequency is

equal to the wave frequency when it strikes the material. Thus, the energy loss is due to frictional and viscous.

Absorptive material controls sound waves by 2 mechanism, viscous-flow losses and internal friction. Sound absorption happens when the sound waves hit the absorbent materials. The absorbent materials should have porous characteristic. The ability to absorb depends on wavelength (or size), thus, the absorption at low frequency is not as good as at high frequency. Before using the sound absorbent materials, choose the one that comply with the sound frequency. Absorbent materials can control reflective sound but cannot control sound that moved through shields and barriers. Therefore, the sound absorbent materials were used on walls and ceiling in order to prevent echoes and reverberation noise, but, not used as shields and barriers, or the enclosures in order to reduce the sound that moved through them.

2.5.5.2 Sound absorption calculation

When there is a need to reduce sound levels in the office, it can be done by using an absorbent material. In order to find the total absorption, it can be calculated in equation form,

$$a = \alpha_1 s_1 + \alpha_2 s_2 + \dots + \alpha_n s_n$$

when

A = The sum of sound absorbed. Their unit is called Sabin.

α = Absorption coefficient

s = Surface area

After the A value is obtained, and then the reverberant field noise can be calculated. In equation form, this is expressed as follows

$$NR = 10 \log (A_2 / A_1)$$

When

NR = Reduction in reflective noise level, the unit is dB.

A1 = The sum of sound absorption in the office before the absorbent material are installed, the units are sabins

A2 = The sum of sound absorption in the office after the absorbent materials are installed, the units are sabins.

Generally, when the absorbent materials are installed, it can reduce the noise levels to about 12-15 decibels (A).

2.5.5.3 Sound screen

Sound screen can be used to cover the sound source. The absorbent material can be used to cover to the side, in which the sound waves can directly hits. These applications will help control the noises, and, to make noise control is more efficient.

2.5.5.4 Sound transmission

Vibrating material causes the air nearby vibrates, thus, that material acts like a new sound source but with less energy than the first one because of the vibration in the material when the first hits by the sound waves. This loss of the wave's energy called transmission loss (TL), in which it depends on the property of each material.³⁵

The efficiency of sound reduction, such as by blocking, dispersing, or transmitting, and the design of the material. The transmission loss will increase when the frequency increased.

Practically, the transmission coefficient, by using Greek letter τ (tau), it is the ratio of the transmitted sound waves to the incident sound waves. In equation form,

2.5.5.5 Silencers

There are 2 types of silencers in which it is according to the characteristics.

1) Dissipative silencers. It works by dissolves the sound energy into the heat energy, by installing sound absorbent materials that have small holes for the purpose of dispersing the sound that went through the absorbent material that was set behind a metal sheet.

2) Reactive silencers can reduce the sound by using geometric shape of the silencer. It can reduce the sound at frequency ranges that is not wide as

the first silencer. Thus, in using this type of silencer, the frequency should be matched with the absorbent material used. Generally, it works well in low frequency.

2.5.5.6 Vibration reducing materials

There are two types of materials that used for reducing or preventing the vibration.

1) Homogeneous damping. This type of material has a single layer and was covered or sprayed with a high-loss, such as asphaltic or homogeneous plastic. They may build with a panel surface. When vibration occurs, this panel surface will flexes or has an extensional motion such that resulting in a significant loss. The capability of these materials depends on ambient temperature, and the ratio of the thickness and the density of the panel surface.

2) Constrained – layer damping consists of viscoelastic layer that causes the outer retaining layers to become stiff but not thick, such as aluminum or steel. Usually, the thickness constrained layer and outer layer is about 1/3 of the thickness of the panel. The reason in using these two vibration reduction materials is to resist the expansion and compression of viscoelastic material until a sheer stress occurs, in which it causes dissipation of the vibration energy. A creation of space-layer will help increase shear stresses in lesser elastic layer to be more efficient.

2.6 Related research work

2.6.1 Wichai Rairat (2003) studied about the design and measured the efficiency of sound reducing instrument, type plenum chamber, both has and has not have the absorbent wick. The plenum chamber measures 1.5 meters in width, 1.5 meters in length, and 2.5 meters in height. It has sound absorbent materials installed from inside, and all sides. It also has a 7 pieces of wide absorbent wicks, and put them on top of each other to form a layer with 125 millimeters apart. There are 3 way of sound reducing being tested. 1. Reducing the sound waves at the same point. 2. Reducing the sound waves around the entrance of the instruments. 3. Reducing the sound waves by showing dispersion lines of the waves. From the study, it was discovered that the different of sound levels both before and after the installation of instruments, the plenum chamber type, with and without the wicks, that went through

every test and every frequency, and especially in the sound reduction at the same point tested, has a statistical significant difference ($p\text{-value} < 0.001$). The plenum chamber, the one that has wicks, it can reduce sound waves at lower frequency better than at higher frequency. At a high frequency, it does not have the ability to reduce the sound waves as in plenum chamber without the wicks type. These results from the sound reduction tests, which both at the same point, and at the entrance of the instruments. In conclusion, the study claimed that in order to reduce the noise of a fan, Plenum chamber can do the job, but if the wick is add into it, it will be more efficient only in a low frequency.¹⁵

2.6.2 Napol Gieatgongmanee (2010) studied about how to apply the used of sound absorbent material to its maximum efficiency. By conducting a model with ratio 1:5 to test the sound and using absorbent fiber plastic and a surface covering material such as grated steel that has holes, and a wire screen. He found that in using the material with ratio of the opening area and a total area which has high values, therefore it will make the insulator to be more efficient. And, to install the materials in the appropriate corners, it will help reduce the sound better. Therefore, by using the same sound absorbent material, the instruments were put at 45 degree angle from the ground. From this angle, the materials can absorb the sound best. Also, it can reflect the sound better too. The sum of sound reduction is 3.5dB (A), which means that the sound can be reduced up to 54.40%. When putting a divide concrete to separate a road traffic, the sound levels were reduce to 4.4, 3.7, and 3.2 dB (A). When sound waves are classified according to their frequency, it was found that the sound level was reduced better at frequency 100 to 240 Hz. and 1,600 to 2,000 Hz.²¹

2.6.3 Scotly John Wertel (2000) study of three layer wood dust was deposited on acoustical foam in 2.44 meters by 2.44 meters by 2.44 meters, Plexiglas test chamber. The amount of dust deposited ranging from 3.34 grams / (m to the power of two) to 30.95 grams/ (m to the power of two). The wood dust on the uncoated SONEX foam reduced the sound pressure levels in the chamber by 2 dB at 1,000 Hz, and by 6dB at 4,000 Hz. Similarly, the dust improved the sound absorption by Hypalon coated SONEX foam by 3 dB at 500 Hz and 1 dB at 2,000 Hz.

The wood dust on the uncoated SONEX foam increased the sound pressure levels in the chamber by 6dB at 2,000Hz. And by 1 dB at 1,000 Hz. And 7 dB

at 4,000 Hz. For Hypalon coated SONEX. Vacuuming removed all the wood particulates from the Hypalon coated foam and about 70% of the dust from the uncoated SONEX.²²

2.6.4 Issada Kawprasert (2549) studied about the efficiency of concrete blocks which it has ventilator. The study including ventilator, and the thickness of the appropriate sound screen in order to design, together with the opening holes inside the block that comply with Helm Holth's principle, and then compared with the concrete blocks which available in the market, both the solid and the ventilate blocks with 1 layer and 2 layers. The study found that the smallest holes, 2.5 centimeters, has the soundest proof efficient when compared to the holes with 5.0 and 7.5 centimeters. The sound screen which the top-front with 5.0 centimeters thick, and, the back-bottom with 10.0 centimeters thick has the soundest proof efficient. These two factors were used for designing the holes inside the blocks. It shields the sound best at the frequency 403 Hz. When compare this type of blocks to the type used in the market, it was found that it is more efficient to every frequency used, and obviously better at 315 – 500 Hz. Which was found to be close to the early design. The reduction in the sound levels is higher than the concrete blocks with ventilator that found in the market by 18 – 20 decibels.²³

CHAPTER III

MATERIALS AND METHODS

3.1 Study designed

This study is a quasi-experimental study to examine the noise levels of machines during the cleaning process in the Jewelry Cleaning Department. It includes; noise reduction in the jewelry cleaning machine by installing noise absorbent materials inside the machine, installation of noise screen at the area where both hands can be placed inside to do a spray wash work on the jewelry, in which, the noise levels will be compared both “before” and “after” the adjustment to the machine in order to use as guidance to others machine improvement later on. The study can be divided into 3 parts as follows;

- 1) The study of noise levels from the machines in the working area.
- 2) Study the noise levels from the jewelry cleaning machines while in the process of cleaning.
- 3) Data collection.

3.1.1 The study of noise levels from the machines in the working area.

3.1.1.1 Study the noise levels from the machines while in the process of cleaning.

It can be done by measures the noise levels from the three machines in the area of Jewelry Cleaning Department while in the process of cleaning, as follows;

- 1) All measuring instruments must be calibrated to ensure measurement accuracy. Prepare the forms for results recording, and camera for data recording.
- 2) The researcher and research assistants congregated in the meeting to explain the procedure of data collection.

3) The measuring instrument was set up on a tripod, in which, it was set in the front of the machine about 60 centimeters away and 159 centimeters above the floor.

4) Basic noise levels were measured at Scale A level.

5) Measuring the noise levels of when operating the socket cleaning equipment, hot-air blower, and the jewelry cleaning machine.

6) Measure the noise levels of at Scale Laeq, one time for 5 minutes.

3.1.1.2 Study the noise levels of from the jewelry cleaning machines while in the process of cleaning.

According to the examination and analysis of the source of noise from the jewelry cleaning machine, it was found 2 sources of noise working continuously, thus, the noise occurred simultaneously, that is;

1) The noise of hydraulic pressure of 150 psi that bumped inside at the bottom part of the jewelry cleaning machine, it was made of stainless sheet of 0.9 mm thick. Therefore, it caused the surface of stainless to vibrate and thus the noise occurred.

2) The noise occurred by the high pressure of water flowing through the spray head inside the spray wash machine.

In the process of spray wash cleaning the jewelry, there are 3 pathways of the noise, as follows;

1) The noise travels directly from its source to the worker, known as direct noise or airborne noise.

2) The noise travels through the structure of jewelry cleaning machine to the worker, known as structure-borne noise.

3) The reflection of noise travels through the air, from the walls, floor, and the ceiling, to the worker, known as reverberant or reflected noise.

3.1.2 Noise pathways.

According to the principle of the reflection of noise and the noise transfers; when the spray wash cleaning is in the process, then, the noise wave will spread out from spray head at the pressure of 150 Psi, in which this hydraulic pressure bumped

into the stainless at the bottom part of the jewelry cleaning machine caused reflection of noise inside the spray wash cleaning machine, and moved past the machine wall through the outside. Moreover, there is a diffusion of noise wave inside the jewelry cleaning machine passed through the opening holes where both hands can be placed inside the machine to wash the jewelry. From the data as mentioned, the researcher had adjusted the machine in order to reduce the noise by installing noise absorbent material inside the machine, and also screened off the holes where both hands can go through to wash the jewelry as well, in which the installing detailed are as the following;

- 1) The noise absorbent materials are installed inside the jewelry cleaning machine to absorb the noise that occurred during the cleaning process. There are six sides all around inside the machine including; the top, the bottom, the left, the right, the front, and the back. These installations will reduce the noise transfers.

- 2) Installing noise screen right at the holes where both hands can go through to wash the jewelry in the jewelry cleaning machine in order to let the noise reflect back and also to reduce the noise transfers as well.

Each type of the noise absorbent materials does not have the same efficiency in absorbing the noise. It depends on the characteristics of each of them. In this study, the noise absorbent material used for installing inside of the jewelry cleaning machine was Elastomeric foam based on synthetic rubber (SUPER SILENCE), that has the density of 140 kg/m³ and 25mm. thick. There are the reasons for selecting elastomeric foam;

- 1) It is safe for the person who installing it, and for the workers as well because it does not compose of rock wool, glass wool that can effect on human health such as allergies.

- 2) It can absorb the noise at the same frequency levels of the disturbing noise in the working area of jewelry cleaning department. By means of reference from Table 3-1 shows the noise absorption efficiency of SUPER SILENCE.

Table 3-1 The noise absorption efficient of the SUPER SILENCE.

Thickness (mm)	Octave band centre frequency(Hz)					
	125	250	500	1000	2000	4000
	Octave band absorption coefficient acc.to EN ISO 354					
10	0.04	0.04	0.12	0.3	0.74	1
15	0.01	0.08	0.26	0.69	1	1
20	0.04	0.14	0.51	1	0.95	1
25	0.05	0.16	0.58	1	1	1
50	0.26	0.76	1	0.86	0.99	1

Thickness (mm)	Weighted noise absorption coefficient aw acc to EN ISO 11654				
	10 mm	15 mm	20 mm	25 mm	50 mm
Aw class	0.20(H)	0.30(MH)	0.45(MH)	0.50(MH)	1
	E	D	D	D	A
	Noise Reduction Coefficient (NRC) acc. To ASTM C423				
	0.30	0.51	0.65	0.69	0.90

By means of data from the measuring results of noise frequency split into a scale of octave bands during normal working state at the department of jewelry cleaning on January 28, 2014 BC, when comparing with the recommended frequency spectrum for OSHA noise problems. It was found that the levels of noise frequency was high above the designated level of 90 dB(A) spectrum at the frequency of 250 Hz, 500 Hz, 1 KHz, 2 KHz, 4 KHz, and 8 KHz, at which the frequency level of 2 KHz; the measuring result of highest noise level was 92 dB(A). The second in rank was the frequency level of 4 KHz, in which the measuring result level was 91 dB(A), respectively as shown in Figure 3 -1.

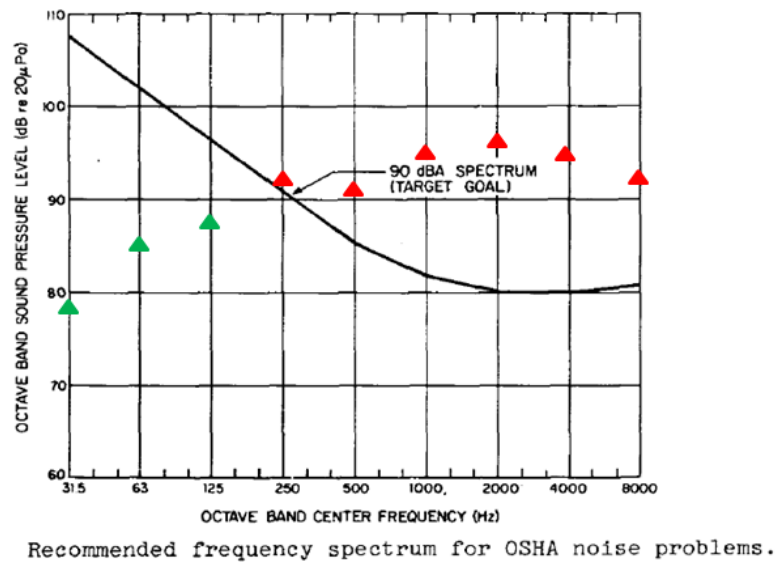

Figure 3-1 The measuring results of noise frequency in octave frequency bands compared with frequency spectrum for OSHA noise problems.

From the measuring results of noise levels that divided into individual frequency bands as compared with the efficiency of the absorption of noise absorbent “SUPER SILENCE” which the thickness was 25 mm can reduce the noise levels at the frequency that reconciled with the loudness noise of the jewelry cleaning machine, especially with the frequency level that higher than the target goal. The noise absorbent “SUPER SILENCE” 25 mm thick has the absorption coefficient value equal to 1, according to their effectiveness in absorbing, it was categorized into high frequency absorption materials as shown in Table 3-2.

Table 3-2: Types of noise proof material identified from the noise reduction coefficient. (Noise Reduction Coefficient, NRC) (Cowan, J.P., 1994)

Noise absorption coefficient	NRC	Types of material
High noise absorption coefficient	1.0	Special designed material that has high absorption ability to noise.
	0.9	High porous ceiling.
	0.8	upholstered chair in the meeting room
	0.7	Thick curtain
	0.6	Mirror
	0.5	Upholster
	0.4	
Medium noise absorption coefficient	0.3	-Flat floor -Audience who sit on the wooden or metal chair. Thick carpet of concrete floor.
	0.2	
Noise reflected back	0.1	- Wooden or metal chair no people are sitting on. - Light weight carpet. - Trees -Thin curtain - Glass windows, wooden window frame.
	0	- Plaster of Paris - gypsum board - Concrete with smooth surface - Enameled brick - Marble - Glass tile - Water surface.

3) The natural characteristics of noise absorbent materials appropriated for the working environment for; humidity resistant, corrosion resistant to alkaline water because of the waste water from jewelry cleaning process having the nature of an alkaline (pH10) and has elastic ability up to 30-40% since the material has to received hydraulic pressure of 150 psi.

4) The surface of materials can not catch on fire since there is no contribution to a fire, no significant smoke release with any flaming droplets or particles expected in which it is safe from fire hazard.

3.1.3 The steps for noise absorbent materials and the plastic screen around the holes, where both hands can slot into them, to be installed, as follows;

1) Clean the inside of the machine, and then scrub the surface inside of machine in order to prepare for an installation of noise absorbent materials.

2) Installing 6 noise absorbent materials according to the size of the machine.

3) Apply the glue to the surface on the inside of machine and also on the noise absorbent materials as well.

4) Put each of the noise absorbent materials in place on the surface inside of the machine and fasten to it with the screws.

5) Cut the PVC sheet into 6 inches wide and 8 inches long.

6) Screen off the holes, where both hands can go through in order to spray wash the jewelry, by fasten the PVC sheet over the holes with the screws.

When everything mentioned from the above are done, then the machine can be set in the working area with the connection to the hydraulic pressure and the electrical system in order that workers can conduct experimentation on normal working process for 30 days.

3.2 Data collection

The researcher has designed the method of how to collect the data, including;

3.2.1 All measurement instruments must be calibrated to ensure measurement accuracy. The camera and prepare for results recorded.

3.2.2 The researcher and research assistants congregated in the meeting to explain the procedure of data collection.

3.2.3 Determine the points in order to set the instruments by marked a position where the tripod to be set as follows;

1) The measurement point; at the front around the hole in which it used for left hand to slot into them, the front of the midway between the holes in which it used for both left and right hand to slot into them, the front around the hole in which it used for right hand to slot into them, on the side and the back of the jewelry cleaning machine. The distance was determined to be 60 centimeters away from the jewelry cleaning machine, and 159 centimeters above the floor.

2) The measurement point on the bottom of the jewelry cleaning machine at the distance of 60 centimeters away from the machine, and 30 centimeters above the floor.

3) The measurement point on the top of the jewelry cleaning machine at the distance of 60 centimeters away from the machine.

3.2.4 Set the measurement instruments on tripod. Measure the noise, both before and after an adjustment to the jewelry cleaning machine, 5 times for each point, at which 7 of them all for 5 minutes each.

3.2.5 Turn the water on at the hydraulic pressure level of 150 psi.

3.2.6 Measurement the noise while machine in the cleaning process, both before and after an adjustment of Scale C, Scale A. The levels of noise frequency bands for Scale C at frequency levels of 100 Hz, 125 Hz, 160 Hz, 200 Hz, 250 Hz, 315 Hz, 400 Hz, 500 Hz, 630 Hz, 800 Hz, 1 KHz, 1.25 KHz, 1.6 KHz, 2,000 Hz, 2.5 KHz, 3.15 KHz, 4 KHz, and 5 KHz.

3.2.7 Measurement the basic noise level for Scale A, and the background noise level will be measured both before and after an adjustment, in which the background noise level is less than 78 dB(C).

3.2.8 Measurement the noise after an adjustment the cleaning machine.

3.3 Material and Equipment

3.3.1 The materials used for machine adjustment.

1) A porous plastic that can absorb noise known as Super silence, it has the density of 140 kg/m^3 , and the thickness of 25 mm. The elongation is 40 %, the tensile strength is 60-90 kPa, and the thermal conductivity is 0.047 w/ (m-k) .

2) The PVC sheet used to screen off the holes, where both hands can slot into them, is 6 inches in width and 8 inches in length.

3.3.2 Equipment used in the experiment.

1) Noise level meter that comply with the standard IEC 651 Type 2 (international Electonical Commission 651 Type 2) Trademark CASELLA Model CEL – 6X0 Serial No. 3081238.

2) Wind Screen. There is a fan that turning on in the working area, as well as mist, in which the wind current and the mist can effect to the loudness level of the noise. Thus, the noise may deviate from its actuality.

3) Tripod used for placing the measuring instrument on top.

4) Camera and its apparatus to be used for recording the data.

3.3.3 The interpretation of the study in improving the jewelry spray wash machine may have 2 intervened factors, as follows;

1) The installed noise absorbent materials, when continued using them over the period of time can wear away as the time goes by. The ageing materials may have an effect to the ability to absorb the noise.

2) This study is a quasi-experimental study in an actual working area in which the reflection of noise may occurred as a results.

3.4 Statistical Analysis

In an analysis of data, the researcher using computer software SPSS Program analyses and Wilcoxon Signed-Rank test used to compare noise pressure level between with and without NOISE ABSORPTION material.

CHAPTER IV

RESULTS

This research was a quasi-experimental study with the aim to determine the noise levels (dB) at certain noise frequencies (Hz) of jewelry cleaning machine injected with high hydraulic pressure, and to compare the noise volume before and after the improvement of sound absorption material install in the machine. The work place is a manufacture and assembly of gems located in the central region of Thailand. The study was divided into 3 parts as follows;

- 1) Primary Survey and Preparation of Appropriate Tools.
- 2) Improvement of Noise Reduction on Jewelry Cleaning Machine.
- 3) A measure of noise levels “before” and “after” some improvement of the jewelry cleaning machine.

4.1 Primary Survey and Preparation of Appropriate Tools

4.1.1 Production Area

The workshop is designed for a staff of 22 workers. Working space is rectangular of 369.60 cubic meters, a dimension of 15.40 m (Width) x 6.00 m (Long) x 4.00 m (High).

4.1.2 Cleaning Process

- 4.1.2.1 Receive product from burnout process.
- 4.1.2.2 Remove lime stone by tapping product on the metal base.
- 4.1.2.3 Clean up the mold in the mold cleaning machine.
- 4.1.2.4 After removing the lime stone, put it in cleaning machine by using water pressure at 150 psi.

4.1.2.5 Remove the cleaned product, dip in the pond 10 to 15 min and bring it on cart for the dryer machine.

4.1.3 Noise levels of Jewelry Cleaning Machine

The researcher was measure 3 machines in cleaning process. The noise was measured by Octave weighting "A" and Octave time const "Fast" at a distance of 60 cm from the machine, and 159 cm above the floor. Reading the noise levels was performed for 5 min in front of machines. It was found that noise levels of the jewelry cleaning machine was 93.0 dB(A), the mold cleaning machine was 78.9 dB(A) and the dryer machine was 71.1 dB(A). Regardless, the background noise level (baseline) was less than 78 dB(C). (Table 4-1)

Table 4-1 The results of noise measured at Cleaning Process.

No.	Machines	Noise levels (dB(A))
1	Box Cleaning machine	78.9
2	Jewelry Cleaning machine	93.0
3	Dryer machine	71.1

4.1.4 Structures of Jewelry Cleaning Machine

- 4.1.4.1 Safety glass 6 mm thick for picking the lid up and down.
- 4.1.4.2 Spaces for working hands, 14 cm diameter of 2 channels.
- 4.1.4.3 The cleaning machine made for stainless steel 1.2 mm thickness.
- 4.1.4.4 At the top of cleaning machine have the nozzle or jet spray.
- 4.1.4.6 PVC drain pipe, 1½ inch in diameter.

4.1.5 Source of Noise

Jewelry cleaner is connected to the water pump at 150 psi. When power is on the cleaning jewelry pump injects high pressure water through the nozzle to the product then it is making a noise as follows;

- 4.1.5.1 Noise generated by water injector.
- 4.1.5.2 Noise from the impact of a water cleaning jewelry.

4.1.5.3 Echoes reflected from the walls inside the jewelry cleaner.

6.1.5.4 Resonance noise inside the box.

4.2 Improvement of Noise Reduction on Jewelry Cleaning Machine

4.2.1 Improved sound-absorption

An elastomeric foam [synthetic rubber (Super Silence[®])] was used to improve the noise reduction. The rubber (140 kg/m³-density and 25 mm-thick) was affixed to the inside surface of the machine to all sides. (i.e. front-back, left-right, and top-bottom)

The process is as follows;

4.2.1.1 Cut the lining material to the size that fits to the inside walls of jewelry cleaner.

4.2.1.2 The material attached to the bottom of cleaning jewelry were made a 2 mm hole to allow water to flow through.

4.2.1.3 Clean the inside and outside of the machine.

4.2.1.4 Lining and affixing the sound absorption material using glue.

4.2.1.5 Then, fasten the material firmly.

4.2.2 Blocking the hands channels

A plastic sheet (6-cm wide x 8 cm-long) was used to block the space for both hands. Each hand insertion channel is 14 cm in diameter.

4.3 A measurement of Noise levels “before” and “after” the improvement of the jewelry cleaning machine.

4.3.1 The measurement of noise levels for seven points before an improvement of the jewelry cleaning machine are as follows;

4.3.1.1 The measurement point at the front of machine (Left).

In the studies, it was found the average of noise levels before an improvement as follows; at the level of Scale A was 90.6 dB, at the level of Scale C was 91.6 dB, and at the frequency level of 100 Hz was 60.6 dB, the frequency level of 125 Hz was 66.2 dB, the frequency level of 160 Hz was 68.2 dB, the frequency level of 200 Hz. was 73.4 dB, the frequency level of 250 Hz was 73.2 dB, the frequency level of 315 Hz. was 75.2 dB, the frequency level of 400 Hz. was 70.4 dB, the frequency level of 500 Hz was 69.4 dB, the frequency level of 630 Hz. was 70.5 dB, the frequency level of 800 Hz. was 69.6 dB, the frequency level of 1 KHz. was 70.8 dB, the frequency level of 1.250 KHz was 74.1 dB, the frequency level of 1.6 KHz. was 75.4 dB, the frequency level of 2 KHz was 76.4 dB, the frequency level of 2 KHz was 77.5 dB, the frequency level of 3.15 KHz was 77.5 dB, the frequency level of 4 KHz was 82.1 dB, and the frequency level of 5 KHz was 84.1 dB, respectively (Table 4-2)

Table 4-2 The results of noise attenuation at the front of machine (Left) before the improvement.

Frequency levels	Noise level (dB)					Mean
	No.1	No.2	No.3	No.4	No.5	
Laeq	90.6	90.6	90.4	90.3	90.6	90.5
Lceq	91.7	91.7	91.4	91.3	91.7	91.6
100 Hz	60.9	60.9	60.6	60.0	60.5	60.6
125 Hz	66.2	65.7	66.2	66.7	66.0	66.2
160 Hz	67.8	67.8	68.1	68.8	68.4	68.2
200 Hz	73.3	74.0	73.8	72.3	73.8	73.4

Table 4-2 The results of noise attenuation at the front of machine (Left) before the improvement. (cont.)

Frequency levels	Noise level (dB)					Mean
	No.1	No.2	No.3	No.4	No.5	
250 Hz	73.4	73.2	73.0	73.5	72.7	73.2
315 Hz	75.7	75.2	75.2	75.7	74.5	75.2
400 Hz	70.3	70.5	70.6	69.9	70.7	70.4
500 Hz	69.5	69.6	69.1	69.4	69.5	69.4
630 Hz	70.8	70.3	70.7	70.8	70.1	70.5
800 Hz	69.8	69.5	69.6	69.7	69.5	69.6
1 KHz	70.6	70.6	71.1	70.7	70.9	70.8
1.25 KHz	74.1	74.0	74.3	73.9	74.2	74.1
1.6 KHz	75.6	75.4	75.3	75.3	75.3	75.4
2 KHz	76.3	76.5	76.6	76.6	76.1	76.4
2.5 KHz	77.5	77.4	77.6	77.5	77.3	77.5
3.15 KHz	78.9	78.7	79.1	79.0	78.7	77.5
4 KHz	82.1	82.0	82.0	81.9	82.2	82.1
5 KHz	84.1	84.1	84.0	83.9	84.3	84.1

4.3.1.2 The measurement at the front of machine (Middle).

In the studies, it was found the average of noise levels before an improvement as follows; at the level of Scale A was 89.9 dB, at the level Scale C was 90.7 dB, and at the frequency level of 100 Hz was 59.9 dB, the frequency level of 125 Hz was 64.2 dB, the frequency level of 160 Hz was 65.7 dB, the frequency level of 200 Hz was 75.9 dB, the frequency level of 250 Hz was 74.7 dB, the frequency level of 315 Hz was 77.1 dB, the frequency level of 400 Hz was 70.6 dB, the frequency level of 500 Hz was 69.2 dB, the frequency level of 630 Hz was 68.8 dB, the frequency level of 800 Hz was 69.8 dB, the frequency level of 1 KHz. was 71.1 dB, the frequency level of 1.25 KHz was 73.3 dB, the frequency level of 1.6 KHz was 73.9 dB, the frequency level of 2 KHz was 74.7 dB, the frequency level of 2.5 KHz. was

76.3 dB, the frequency level of 3.15 KHz was 78.2 dB, the frequency level of 4 KHz was 80.7 dB, and the frequency level of 5 KHz was 82.3 dB, respectively. (Table 4-3)

Table 4-3 The results of noise attenuation at the front of machine (Middle) before the improvement.

Frequency levels	Noise level (dB)					Mean
	No.1	No.2	No.3	No.4	No.5	
Laeq	89.4	89.3	89.4	90.7	90.8	89.9
Lceq	90.1	90.0	90.1	91.6	91.8	90.7
100 Hz	59.9	60.0	60.6	59.3	59.7	59.9
125 Hz	63.8	64.7	63.8	64.2	63.7	64.0
160 Hz	64.8	66.6	65.0	66.5	65.6	65.7
200 Hz	76.5	76.7	76.1	75.1	75.1	75.9
250 Hz	74.5	74.3	74.3	75.2	75.2	74.7
315 Hz	76.7	76.6	76.7	77.7	77.6	77.1
400 Hz	70.6	70.5	70.7	70.6	70.6	70.6
500 Hz	69.6	69.2	69.0	68.9	69.5	69.2
630 Hz	68.5	68.4	68.5	69.4	69.3	68.8
800 Hz	69.7	69.5	69.5	70.1	70.3	69.8
1 KHz	71.1	70.8	71.2	71.0	71.4	71.1
1.25 KHz	72.6	72.5	72.5	74.3	74.6	73.3
1.6 KHz	73.1	72.9	72.9	75.2	75.5	73.9
2 KHz	74.2	74.4	74.2	75.5	75.5	74.7
2.5 KHz	75.4	75.7	76.0	77.0	77.2	76.3
3.15 KHz	77.5	77.5	77.7	79.2	79.3	78.2
4 KHz	79.8	79.8	80.0	81.9	82.3	80.7
5 KHz	81.4	81.2	81.3	83.8	84.1	82.3

4.3.1.3 The measurement at the front of machine (Right).

In the studies, it was found the average of noise levels before an improvement as follows; at the level of Scale A was 89.9 dB, at the level Scale C was 90.7 dB, and at the frequency level of 100 Hz was 59.9 dB, the frequency level of 125 Hz was 64.0 dB, the frequency level of 160 Hz was 65.7 dB, the frequency level of 200 Hz was 75.9 dB, the frequency level of 250 Hz was 74.7 dB, the frequency level of 315 Hz was 77.1 dB, the frequency level of 400 Hz was 70.6 dB, the frequency level of 500 Hz was 69.2 dB, the frequency level of 630 Hz was 68.8 dB, the frequency level of 800 Hz was 69.8 dB, the frequency level of 1 KHz was 71.1 dB, the frequency level of 1.25 KHz was 73.3 dB, the frequency level of 1.6 KHz was 73.9 dB, the frequency level of 2 KHz was 74.7 dB, the frequency level of 2.5 KHz was 76.3 dB, the frequency level of 3.15 KHz was 78.2 dB, the frequency level of 4 KHz was 80.74dB, and the frequency level of 5 KHz was 82.3 dB, respectively.(Table 4-4)

Table 4-4 The results of noise attenuation at front of machine (Right) before the improvement.

Frequency levels	Noise level (dB)					Mean
	No.1	No.2	No.3	No.4	No.5	
Laeq	89.4	89.3	89.4	90.7	90.8	89.9
Lceq	90.1	90.0	90.1	91.6	91.8	90.7
100 Hz	59.9	60.0	60.6	59.3	59.7	59.9
125 Hz	63.8	64.7	63.8	64.2	63.7	64.0
160 Hz	64.8	66.6	65.0	66.5	65.6	65.7
200 Hz	76.5	76.7	76.1	75.1	75.1	75.9
250 Hz	74.5	74.3	74.3	75.2	75.2	74.7
315 Hz	76.7	76.6	76.7	77.7	77.6	77.1
400 Hz	70.6	70.5	70.7	70.6	70.6	70.6
500 Hz	69.6	69.2	69.0	68.9	69.5	69.2
630 Hz	68.5	68.4	68.5	69.4	69.3	68.8
800 Hz	69.7	69.5	69.5	70.1	70.3	69.8
1 KHz	71.1	70.8	71.2	71.0	71.4	71.1

Table 4-4 The results of noise attenuation at front of machine (Right) before the improvement. (cont.)

Frequency levels	Noise level (dB)					
	No.1	No.2	No.3	No.4	No.5	Mean
1.25 KHz	72.6	72.5	72.5	74.3	74.6	73.3
1.6 KHz	73.1	72.9	72.9	75.2	75.5	73.9
2 KHz	74.2	74.4	74.2	75.5	75.5	74.7
2.5 KHz	75.4	75.7	76.0	77.0	77.2	76.3
3.15 KHz	77.5	77.5	77.7	79.2	79.3	78.2
4 KHz	79.8	79.8	80.0	81.9	82.3	80.7
5 KHz	81.4	81.2	81.3	83.8	84.1	82.3

6.3.1.4 The measurement at the beside of machine.

In the studies, it was found the average of noise levels before an improvement as follows; At the level of Scale A was 87.8 dB, at the level Scale C was 88.1 dB, and at the frequency level of 100 Hz was 62.0 dB, the frequency level of 125 Hz was 71.5 dB, the frequency level of 160 Hz was 70.1 dB, the frequency level of 200 Hz was 70.9 dB, the frequency level of 250 Hz was 71.8 dB, the frequency level of 315 Hz was 71.4 dB, the frequency level of 400 Hz was 71.6 dB, the frequency level of 500 Hz was 72.3 dB, the frequency level of 630 Hz was 72.1 dB, the frequency level of 800 Hz was 74.7 dB, the frequency level of 1 KHz was 75.0 dB, the frequency level of 1.25 KHz was 76.5 dB, the frequency level of 1.6 KHz was 74.3 dB, the frequency level of 2 KHz was 71.9 dB, the frequency level of 2.5 KHz was 72.6 dB, the frequency level of 3.15 KHz was 79.1 dB, the frequency level of 4 KHz was 77.3 dB, and the frequency level of 5 KHz was 79.4 dB, respectively. (Table 4-5)

Table 4-5 The results of noise attenuation at the beside of machine before the improvement.

Frequency levels	Noise level (dB)					
	No.1	No.2	No.3	No.4	No.5	Mean
Laeq	87.8	87.8	87.8	87.6	87.7	87.8
Lceq	88.1	88.1	88.2	88.1	88.1	88.1
100 Hz	63.1	62.1	61.8	61.5	61.7	62.0
125 Hz	71.6	71.3	71.4	71.4	71.7	71.5
160 Hz	70.5	70.5	70.4	69.1	69.9	70.1
200 Hz	71.2	71.2	71.2	70.5	70.6	70.9
250 Hz	72.6	72.5	72.2	70.7	70.9	71.8
315 Hz	71.1	71.1	70.7	71.8	72.0	71.4
400 Hz	72.0	71.3	71.4	71.4	71.9	71.6
500 Hz	72.5	72.3	72.4	71.9	72.6	72.3
630 Hz	72.3	72.6	72.6	71.7	71.5	72.1
800 Hz	75.6	75.5	75.2	73.9	73.5	74.7
1 KHz	75.3	75.4	75.2	74.5	74.7	75.0
1.25 KHz	75.9	76.1	75.9	77.2	77.4	76.5
1.6 KHz	74.4	74.5	74.5	73.9	74.2	74.3
2 KHz	72.3	72.3	72.1	71.1	71.4	71.9
2.5 KHz	72.5	72.5	72.7	72.7	72.6	72.6
3.15 KHz	79.2	79.3	79.3	79.0	78.8	79.1
4 KHz	77.3	77.2	77.2	77.3	77.3	77.3
5 KHz	79.5	79.4	79.7	79.2	79.1	79.4

4.3.1.5 The measurement at the back of machine.

In the studies, it was found the average of noise levels before an improvement as follows; at the level of Scale A was 85.3 dB, at the level Scale C was 85.8 dB, and at the frequency level of 100 Hz was 68.4 dB, the frequency level of 125 Hz was 77.0 dB, the frequency level of 160 Hz was 71.6 dB, the frequency level of 200 Hz was 64.1 dB, the frequency level of 250 Hz was 73.0 dB, the frequency level of 315 Hz was 68.6 dB, the frequency level of 400 Hz was 68.2 dB, the

frequency level of 500 Hz was 68.7 dB, the frequency level of 630 Hz was 69.0 dB, the frequency level of 800 Hz was 70.2 dB, the frequency level of 1 KHz was 70.0 dB, the frequency level of 1.25 KHz was 70.1 dB, the frequency level of 1.6 KHz was 73.4 dB, the frequency level of 2 KHz was 73.4 dB, the frequency level of 2.5 KHz was 73.4 dB, the frequency level of 3.15 KHz was 74.7 dB, the frequency level of 4 KHz was 75.3 dB, and the frequency level of 5 KHz was 75.7 dB, respectively.(Table 4-6)

Table 4-6 The result of noise attenuation at the back of machine before the improvement.

Frequency levels	Noise level (dB)					
	No.1	No.2	No.3	No.4	No.5	Mean
Laeq	85.3	85.3	85.2	85.3	85.1	85.3
Lceq	85.9	85.9	85.8	85.8	85.7	85.8
100 Hz	68.5	68.5	68.4	68.5	68.1	68.4
125 Hz	77.0	76.9	76.8	76.9	77.2	77.0
160 Hz	71.3	71.8	71.9	71.8	70.9	71.6
200 Hz	64.1	64.6	64.0	63.7	64.3	64.1
250 Hz	73.0	73.3	73.1	72.5	73.3	73.0
315 Hz	68.7	68.4	68.2	68.8	68.8	68.6
400 Hz	68.1	68.1	68.1	68.0	68.7	68.2
500 Hz	68.6	69.0	68.5	68.7	68.6	68.7
630 Hz	68.9	69.2	68.9	69.0	69.2	69.0
800 Hz	70.2	70.8	69.8	70.0	70.2	70.2
1 KHz	69.9	70.2	69.7	70.1	70.0	70.0
1.25 KHz	71.3	71.3	71.1	71.1	70.9	71.1
1.6 KHz	73.7	73.4	73.2	73.6	73.2	73.4
2 KHz	73.5	73.6	73.4	73.4	73.0	73.4
2.5 KHz	73.3	73.2	73.5	73.4	73.3	73.4
3.15 KHz	74.8	74.6	74.8	74.6	74.5	74.7
4 KHz	75.5	75.4	75.3	75.3	75.1	75.3
5 KHz	75.7	75.9	75.8	75.7	75.6	75.7

4.3.1.6 The measurement at above of the machine.

In the studies, it was found the average of noise levels before an improvement as follows; at the level of Scale A was 85.2 dB, at the level Scale C was 88.6 dB, and at the frequency level of 100 Hz was 70.3 dB, the frequency level of 125 Hz was 76.1 dB, the frequency level of 160 Hz was 72.4 dB, the frequency level of 200 Hz was 67.7 dB, the frequency level of 250 Hz was 74.6 dB, the frequency level of 315 Hz was 70.8 dB, the frequency level of 400 Hz was 71.0 dB, the frequency level of 500 Hz was 72.8 dB, the frequency level of 630 Hz. was 71.1 dB, the frequency level of 800 Hz. was 73.2 dB, the frequency level of 1 KHz was 73.1 dB, the frequency level of 1.25 KHz was 73.3 dB, the frequency level of 1.6 KHz was 75.8 dB, the frequency level of 2 KHz was 74.3 dB, the frequency level of 2.5 KHz. was 74.6 dB, the frequency level of 3.15 KHz was 74.5 dB, the frequency level of 4 KHz was 72.9 dB, and the frequency level of 5 KHz was 72.5 dB, respectively. (Table 4-7)

Table 4-7 The results of noise attenuation at above of machine before the improvement.

Frequency levels	Noise level (dB)					Mean
	No.1	No.2	No.3	No.4	No.5	
Laeq	85.1	85.3	85.3	85.2	85.2	85.2
Lceq	88.6	88.6	88.6	88.6	88.5	88.6
100 Hz	70.5	69.9	70.7	70.0	70.4	70.3
125 Hz	74.8	75.2	78.4	75.7	76.3	76.1
160 Hz	72.1	72.3	73.5	71.9	72.1	72.4
200 Hz	67.6	68.1	67.4	67.2	67.8	67.6
250 Hz	75.0	75.1	74.2	74.5	74.1	74.6
315 Hz	71.1	70.9	70.0	71.0	70.8	70.8
400 Hz	70.7	70.6	72.1	70.8	71.0	71.0
500 Hz	73.4	73.2	71.5	73.2	72.8	72.8
630 Hz	70.6	70.8	71.9	71.0	71.3	71.1
800 Hz	72.2	72.8	74.6	73.0	73.3	73.2

Table 4-7 The results of noise attenuation at above of machine before the improvement. (cont.)

Frequency levels	Noise level (dB)					
	No.1	No.2	No.3	No.4	No.5	Mean
1 KHz	73.0	72.6	74.1	72.9	72.8	73.1
1.25 KHz	73.3	73.3	73.7	73.2	72.9	73.3
1.6 KHz	75.8	76.3	75.1	76.1	75.8	75.8
2 KHz	74.2	74.3	74.0	74.3	74.4	74.3
2.5 KHz	74.4	74.5	74.6	74.7	74.6	74.6
3.15 KHz	74.2	74.4	75.0	74.6	74.6	74.5
4 KHz	72.9	73.1	72.6	73.1	73.0	72.9
5 KHz	72.4	72.5	72.8	72.5	72.4	72.5

4.3.1.7 The measurement at the bottom of machine.

In the studies, it was found the average of noise levels before an improvement as follows; at the level of Scale A was 95.4 dB, at the level Scale C was 96.4 dB, and at the frequency level of 100 Hz was 68.8 dB, the frequency level of 125 Hz was 78.7 dB, the frequency level of 160 Hz was 77.8 dB, the frequency level of 200 Hz. was 79.9 dB, the frequency level of 250 Hz was 77.1 dB, the frequency level of 315 Hz was 69.83 dB, the frequency level of 400 Hz was 72.0 dB, the frequency level of 500 Hz was 75.3 dB, the frequency level of 630 Hz was 75.2 dB, the frequency level of 800 Hz was 74.5 dB, the frequency level of 1 KHz was 73.0 dB, the frequency level of 1250Hz. was 76.7 dB, the frequency level of 1.6 KHz. was 84.8 dB, the frequency level of 2 KHz was 80.40 dB, the frequency level of 2.5 KHz. was 82.1 dB, the frequency level of 3.15 KHz was 84.0 dB, the frequency level of 4 KHz was 86.1 dB, and the frequency level of 5 KHz was 87.5 dB, respectively. (Table 4-8)

Table 4-8 The results of noise attenuation at the bottom of machine before the improvement.

Frequency levels	Noise level (dB)					Mean
	No.1	No.2	No.3	No.4	No.5	
Laeq	95.6	95.5	95.3	95.3	95.2	95.4
Lceq	96.6	96.5	96.4	96.4	96.2	96.4
100 Hz	68.9	68.9	68.8	68.6	68.8	68.8
125 Hz	79.0	79.0	78.8	78.6	78.4	78.7
160 Hz	77.9	77.2	77.6	78.2	78.1	77.8
200 Hz	79.5	80.1	79.7	79.9	80.2	79.9
250 Hz	77.5	76.9	77.4	76.8	76.9	77.1
315 Hz	68.7	69.5	70.3	70.6	70.1	69.8
400 Hz	71.9	72.0	71.9	72.6	71.7	72.0
500 Hz	75.2	75.1	75.2	75.8	75.3	75.3
630 Hz	75.3	75.4	75.0	75.2	75.0	75.2
800 Hz	74.3	74.2	74.8	75.0	74.4	74.5
1 KHz	73.7	72.8	72.6	72.7	72.9	73.0
1.25 KHz	76.9	76.7	76.5	76.6	76.6	76.7
1.6 KHz	85.7	85.7	83.9	84.1	84.5	84.8
2 KHz	80.7	80.3	80.4	80.4	80.2	80.4
2.5 KHz	82.5	81.5	82.4	82.4	81.6	82.1
3.15 KHz	83.5	84.0	84.0	84.0	84.5	84.0
4 KHz	86.4	86.6	85.9	85.7	85.7	86.1
5 KHz	88.3	88.1	87.0	86.8	87.3	87.5

4.3.2 A measurement of noise levels after an improvement to the jewelry cleaning machine, all seven points, these values are as follows;

4.3.2.1 The measurement at the front of machine (Left).

In the studies, it was found the average of noise levels after an improvement as follows; at the level of Scale A was 86.0 dB, at the level of Scale C

was 86.6, and at the frequency level of 100 Hz was 61.4 dB, the frequency level of 125 Hz was 69.6 dB, the frequency level of 160 Hz was 70.7 dB, the frequency level of 200 Hz was 68.4 dB, the frequency level of 250 Hz was 72.7 dB, the frequency level of 315 Hz was 76.0 dB, the frequency level of 400 Hz was 73.4 dB, the frequency level of 500 Hz was 74.1 dB, the frequency level of 630 Hz was 73.6 dB, the frequency level of 800 Hz was 74.8 dB, the frequency level of 1 KHz was 73.6 dB, the frequency level of 1.25 KHz was 76.1 dB, the frequency level of 1.6 KHz was 74.9 dB, the frequency level of 2 KHz was 74.0 dB, the frequency level of 2.5 KHz was 73.9 dB, the frequency level of 3.15 KHz was 74.1 Hz dB, the frequency level of 4 KHz was 75.1 dB, and the frequency level of 5 KHz was 74.7 dB, respectively. (Table 4-9)

Table 4-9 The results of noise attenuation at the front of machine (Left)after the improvement.

Frequency levels	Noise level (dB)					Mean
	No.1	No.2	No.3	No.4	No.5	
Laeq	85.9	86.0	86.2	85.8	86.0	86.0
Lceq	86.5	86.6	86.8	86.8	86.4	86.6
100 Hz	60.5	61.3	61.1	63.3	61.0	61.4
125 Hz	69.6	69.6	69.6	69.9	69.1	69.6
160 Hz	70.7	70.6	70.7	71.0	70.3	70.7
200 Hz	68.1	68.1	68.8	68.1	69.0	68.4
250 Hz	73.0	72.4	72.9	72.4	72.8	72.7
315 Hz	76.1	75.8	76.6	75.6	75.7	76.0
400 Hz	73.5	73.4	73.4	73.2	73.4	73.4
500 Hz	73.9	74.2	74.4	73.7	74.2	74.1
630 Hz	73.5	73.8	73.7	73.4	73.6	73.6
800 Hz	74.7	74.7	75.0	74.9	74.9	74.8
1 KHz	73.6	73.7	73.8	73.3	73.5	73.6
1.25 KHz	76.1	76.3	76.7	75.5	76.0	76.1

Table 4-9 The results of noise attenuation at the front of machine (Left)after the improvement. (cont.)

Frequency levels	Noise level (dB)					Mean
	No.1	No.2	No.3	No.4	No.5	
1.6 KHz	75.0	74.9	74.9	74.8	74.9	74.9
2 KHz	74.0	74.0	73.9	74.1	74.0	74.0
2.5 KHz	73.8	74.0	74.0	74.0	73.9	73.9
3.15 KHz	74.0	74.1	74.1	74.0	74.3	74.1
4 KHz	75.1	75.2	75.2	74.9	75.0	75.1
5 KHz	74.7	74.8	75.1	74.3	74.6	74.7

4.3.2.2 The measurement at the front of machine (Middle).

In the studies, it was found the average of noise levels after an improvement as follows; at the level of Scale A was 86.4 dB, at the level Scale C was 86.9 dB, and at the frequency level of 100 Hz was 61.5 dB, the frequency level of 125 Hz was 68.8 dB, the frequency level of 160 Hz was 69.8 dB, the frequency level of 200 Hz was 70.2 dB, the frequency level of 250 Hz was 72.6 dB, the frequency level of 315 Hz was 76.3 dB, the frequency level of 400 Hz was 73.6 dB, the frequency level of 500 Hz was 74.1 dB, the frequency level of 630 Hz was 74.2 dB, the frequency level of 800 Hz was 75.4 dB, the frequency level of 1 KHz was 74.4 dB, the frequency level of 1.25 KHz was 77.2 dB, the frequency level of 1.6 KHz was 75.5 dB, the frequency level of 2 KHz was 74.3 dB, the frequency level of 2.5 KHz was 73.9 dB, the frequency level of 3.15 KHz was 74.0 dB, the frequency level of 4 KHz was 75.2 dB, and the frequency level of 5 KHz was 74.7 dB, respectively. (Table 4-10)

Table 4-10 The results of noise attenuation at front of machine (Middle) after the improvement.

Frequency levels	Noise level (dB)					Mean
	No.1	No.2	No.3	No.4	No.5	
Laeq	86.8	86.9	86.0	86.2	86.0	86.4
Lceq	87.4	87.3	86.6	86.8	86.4	86.9
100 Hz	63.0	61.0	61.3	61.1	61.0	61.5
125 Hz	68.3	67.6	69.6	69.6	69.1	68.8
160 Hz	69.0	68.6	70.6	70.7	70.3	69.8
200 Hz	73.2	72.0	68.1	68.8	69.0	70.2
250 Hz	72.7	72.3	72.4	72.9	72.8	72.6
315 Hz	76.7	76.6	75.8	76.6	75.7	76.3
400 Hz	73.8	73.8	73.4	73.4	73.4	73.6
500 Hz	73.8	73.9	74.2	74.4	74.2	74.1
630 Hz	74.9	75.0	73.8	73.7	73.6	74.2
800 Hz	76.2	76.3	74.7	75.0	74.9	75.4
1 KHz	75.5	75.7	73.7	73.8	73.5	74.4
1.25 KHz	78.4	78.5	76.3	76.7	76.0	77.2
1.6 KHz	76.5	76.4	74.9	74.9	74.9	75.5
2 KHz	74.7	75.0	74.0	73.9	74.0	74.3
2.5 KHz	73.7	73.9	74.0	74.0	73.9	73.9
3.15 KHz	73.6	73.6	74.1	74.1	74.3	74.0
4 KHz	75.4	75.4	75.2	75.2	75.0	75.2
5 KHz	74.7	74.5	74.8	75.1	74.6	74.7

4.3.2.3 The measurement at the front of machine (Right).

In the studies, it was found the average of noise levels after an improvement as follows; at the level of Scale A was 81.8 dB, at the level Scale C was 84.1 dB, and at the frequency level of 100 Hz was 60.5 dB, the frequency level of 125 Hz was 65.6 dB, the frequency level of 160 Hz was 67.5 dB, the frequency level of 200 Hz was 75.5 dB, the frequency level of 250 Hz was 73.9 dB, the frequency level

of 315 Hz was 74.6 dB, the frequency level of 400 Hz was 68.4 dB, the frequency level of 500 Hz was 72.5 dB, the frequency level of 630 Hz was 72.4 dB, the frequency level of 800 Hz was 73.3 dB, the frequency level of 1 KHz was 73.0 dB, the frequency level of 1250 Hz was 72.0 dB, the frequency level of 1.6 KHz was 70.5 dB, the frequency level of 2 KHz was 70.7 dB, the frequency level of 2.5 KHz was 67.3 dB, the frequency level of 3.15 KHz was 66.8 dB, the frequency level of 4 KHz was 68.1 dB, and the frequency level of 5 KHz was 66.3 dB, respectively. (Table 4-11)

Table 4-11 The results of noise attenuation at front of machine (Right) after the improvement.

Frequency levels	Noise level (dB)					Mean
	No.1	No.2	No.3	No.4	No.5	
Laeq	81.7	81.8	81.8	81.7	81.8	81.8
Lceq	84.0	84.1	84.1	84.1	84.1	84.1
100 Hz	59.4	61.5	61.1	60.3	60.4	60.5
125 Hz	65.3	65.5	65.6	65.6	65.7	65.6
160 Hz	67.4	67.4	67.6	67.4	67.5	67.5
200 Hz	75.1	75.1	75.6	75.9	75.8	75.5
250 Hz	74.0	73.9	74.1	73.9	73.7	73.9
315 Hz	74.7	74.8	74.7	74.3	74.5	74.6
400 Hz	68.0	68.5	68.7	68.5	68.5	68.4
500 Hz	72.3	72.5	72.6	72.3	72.6	72.5
630 Hz	72.2	72.5	72.4	72.5	72.5	72.4
800 Hz	73.3	73.3	73.4	73.4	73.4	73.3
1 KHz	73.0	73.2	73.1	72.9	72.8	73.0
1.25 KHz	72.0	72.1	71.8	72.0	72.0	72.0
1.6 KHz	70.6	70.6	70.3	70.2	70.8	70.5
2 KHz	70.7	70.6	70.6	70.7	70.6	70.7
2.5 KHz	67.1	67.3	67.3	67.5	67.5	67.3
3.15 KHz	66.7	66.7	66.9	66.6	66.9	66.8

Table 4-11 The results of noise attenuation at front of machine (Right) after the improvement. (cont.)

Frequency levels	Noise level (dB)					
	No.1	No.2	No.3	No.4	No.5	Mean
4 KHz	68.3	68.2	68.0	68.0	67.9	68.1
5 KHz	66.4	66.3	66.2	66.3	66.2	66.3

6.3.2.4 The measurement at beside of machine

In the studies, it was found the average of noise levels after an improvement as follows; at the level of Scale A was 81.3 dB, at the level Scale C was 83.5 dB, and at the frequency level of 100 Hz was 59.9 dB, the frequency level of 125 Hz was 65.5 dB, the frequency level of 160 Hz was 66.9 dB, the frequency level of 200 Hz was 70.4 dB, the frequency level of 250 Hz was 71.5 dB, the frequency level of 315 Hz was 75.2 dB, the frequency level of 400 Hz was 70.4 dB, the frequency level of 500 Hz was 71.7 dB, the frequency level of 630 Hz was 72.4 dB, the frequency level of 800 Hz was 72.4 dB, the frequency level of 1 KHz was 72.7 dB, the frequency level of 1.25 KHz was 71.7 dB, the frequency level of 1.6 KHz was 70.9 dB, the frequency level of 2 KHz was 70.4 dB, the frequency level of 2.5 KHz was 67.0 dB, the frequency level of 3.15 KHz was 66.3 dB, the frequency level of 4 KHz was 67.3 dB, and the frequency level of 5 KHz was 65.4 dB, respectively. (Table 4-12)

Table 4-12 The results of noise attenuation at the beside of machine after the improvement.

Frequency levels	Noise level (dB)					
	No.1	No.2	No.3	No.4	No.5	Mean
Laeq	81.4	81.3	81.3	81.2	81.2	81.3
Lceq	83.6	83.5	83.5	83.4	83.4	83.5
100 Hz	60.3	59.6	60.2	59.0	60.2	59.9
125 Hz	66.1	64.6	65.9	65.5	65.2	65.5

Table 4-12 The results of noise attenuation at the beside of machine after the improvement. (cont.)

Frequency levels	Noise level (dB)					Mean
	No.1	No.2	No.3	No.4	No.5	
160 Hz	67.7	66.1	67.1	66.9	66.7	66.9
200 Hz	71.2	70.3	69.5	70.2	70.6	70.4
250 Hz	71.8	71.8	71.4	71.3	71.2	71.5
315 Hz	75.2	75.3	75.5	75.1	75.1	75.2
400 Hz	70.6	70.6	70.4	69.9	70.3	70.4
500 Hz	72.2	71.9	71.3	71.6	71.4	71.7
630 Hz	72.9	72.5	72.5	72.1	72.0	72.4
800 Hz	72.7	72.3	72.2	72.3	72.3	72.4
1 KHz	72.4	72.4	72.9	72.7	72.9	72.7
1.25 KHz	70.9	71.2	71.2	71.2	71.0	71.1
1.6 KHz	70.9	71.0	70.8	70.8	70.8	70.9
2 KHz	70.4	70.3	70.5	70.4	70.3	70.4
2.5 KHz	67.0	67.1	66.8	66.9	66.9	67.0
3.15 KHz	66.2	66.1	66.4	66.5	66.4	66.3
4 KHz	67.4	67.4	67.3	67.4	67.2	67.3
5 KHz	65.5	65.5	65.3	65.4	65.4	65.4

6.3.2.5 The measurement at back of the machine.

In the studies, it was found the average of noise levels after an improvement as follows; at the level of Scale A was 82.8 dB, at the level Scale C was 85.0 dB, and at the frequency level of 100 Hz was 61.3 dB, the frequency level of 125 Hz was 68.6 dB, the frequency level of 160 Hz was 70.0 dB, the frequency level of 200 Hz was 78.9 dB, the frequency level of 250 Hz was 71.9 dB, the frequency level of 315 Hz was 73.4 dB, the frequency level of 400 Hz was 71.0 dB, the frequency level of 500 Hz was 71.8 dB, the frequency level of 630 Hz was 71.6 dB, the frequency level of 800 Hz was 74.3 dB, the frequency level of 1 KHz was 73.3 dB, the frequency level of 1250 Hz was 73.1 dB, the frequency level of 1.6 KHz was 72.3 dB,

the frequency level of 2 KHz was 71.4 dB, the frequency level of 2.5 KHz was 68.9 dB, the frequency level of 3.15 KHz was 68.8 dB, the frequency level of 4 KHz was 69.6 dB, and the frequency level of 5 KHz was 69.2 dB, respectively. (Table 4-13)

Table 4-13 The results of noise attenuation at back of the machine after the improvement.

Frequency levels	Noise level (dB)					Mean
	No.1	No.2	No.3	No.4	No.5	
Laeq	82.6	82.8	82.7	82.7	82.8	82.8
Lceq	84.9	85.0	85.2	85.0	85.0	85.0
100 Hz	61.8	60.9	61.6	60.6	61.6	61.3
125 Hz	68.9	68.9	69.2	68.1	67.8	68.6
160 Hz	70.3	70.4	70.6	69.5	69.3	70.0
200 Hz	78.8	78.4	79.1	79.1	79.0	78.9
250 Hz	71.7	71.8	72.0	72.0	71.9	71.9
315 Hz	73.3	73.4	74.5	73.0	72.9	73.4
400 Hz	71.0	71.4	71.5	70.8	70.4	71.0
500 Hz	71.7	72.5	71.8	71.7	71.5	71.8
630 Hz	71.6	71.7	71.1	71.7	71.8	71.6
800 Hz	74.2	74.5	74.1	74.6	74.4	74.3
1 KHz	73.2	73.4	73.3	73.2	73.2	73.3
1.25 KHz	72.9	73.7	73.0	72.5	73.3	73.1
1.6 KHz	72.3	72.2	72.1	72.3	72.4	72.3
2 KHz	71.3	71.4	71.1	71.2	71.8	71.4
2.5 KHz	68.9	68.8	69.0	68.8	68.8	68.9
3.15 KHz	67.9	68.4	69.1	69.4	69.3	68.8
4 KHz	69.6	69.6	69.7	69.5	69.7	69.6
5 KHz	69.2	69.2	69.4	69.2	69.1	69.2

6.3.2.6 The measurement at above of machine.

In the studies, it was found the average of noise levels after an improvement as follows; at the level of Scale A is 84.9 dB, at the level Scale C is 86.00 dB, and at the frequency level of 100 Hz. is 67.3 dB, the frequency level of 125 Hz. is 74.8 dB, the frequency level of 160 Hz. is 77.1 dB, the frequency level of 200 Hz. is 81.7 dB, the frequency level of 250 Hz is 75.7 dB, the frequency level of 315 Hz. is 74.0 dB, the frequency level of 400 Hz. is 71.7 dB, the frequency level of 500 Hz is 77.2 dB, the frequency level of 630 Hz. is 78.8 dB, the frequency level of 800 Hz. is 77.5 dB, the frequency level of 1 KHz. is 77.7 dB, the frequency level of 1.25 KHz is 74.1 dB, the frequency level of 1.6 KHz. is 71.4 dB, the frequency level of 2 KHz. is 73.4 dB, the frequency level of 2.5 KHz. is 68.9 dB, the frequency level of 3.15 KHz. is 68.5 dB, the frequency level of 4 KHz. is 69.4 dB, and the frequency level of 5 KHz is 67.3 dB, respectively. (Table 4-14)

Table 4-14 The results of noise attenuation at above of machine after the improvement.

Frequency levels	Noise level (dB)					
	No.1	No.2	No.3	No.4	No.5	Mean
Laeq	84.8	84.9	85.0	85.0	84.9	84.9
Lceq	85.7	85.9	86.4	85.9	85.9	86.0
100 Hz	66.6	67.2	67.8	67.3	67.5	67.3
125 Hz	75.0	74.8	74.7	74.6	75.2	74.8
160 Hz	77.0	77.1	76.8	77.1	77.3	77.1
200 Hz	81.7	81.6	81.6	82.2	81.4	81.7
250 Hz	75.6	75.7	76.1	75.7	75.6	75.7
315 Hz	73.6	73.1	74.5	74.4	74.2	74.0
400 Hz	71.7	71.9	71.7	71.7	71.4	71.7
500 Hz	77.2	77.6	77.3	77.0	76.9	77.2
630 Hz	78.8	78.7	78.6	78.8	79.0	78.8
800 Hz	77.3	77.6	77.7	77.3	77.6	77.5
1 KHz	77.5	77.9	77.9	77.6	77.6	77.7
1.25 KHz	74.3	74.1	74.2	73.9	74.3	74.1

Table 4-14 The results of noise attenuation at above of machine after the improvement. (cont.)

Frequency levels	Noise level (dB)					Mean
	No.1	No.2	No.3	No.4	No.5	
1.6 KHz	71.7	71.7	71.4	71.3	71.0	71.4
2 KHz	72.9	73.8	73.5	73.5	73.1	73.4
2.5 KHz	68.7	68.6	68.8	68.9	69.3	68.9
3.15 KHz	68.5	68.0	68.7	68.7	68.6	68.5
4 KHz	69.4	69.3	69.3	69.4	69.4	69.4
5 KHz	67.3	67.3	67.3	67.3	67.2	67.3

4.3.2.7 The measurement at bottom of machine.

In the studies, it was found the average of noise levels after an improvement as follows; at the level of Scale A was 85.2 dB, at the level Scale C was 88.6 dB, and at the frequency level of 100 Hz was 70.3 dB, the frequency level of 125 Hz was 74.8 dB, the frequency level of 160 Hz. was 77.1 dB, the frequency level of 200 Hz was 81.7 dB, the frequency level of 250 Hz was 75.7 dB, the frequency level of 315 Hz was 74.0 dB, the frequency level of 400 Hz was 71.7 dB, the frequency level of 500 Hz was 77.2 dB, the frequency level of 630 Hz was 78.8 dB, the frequency level of 800 Hz was 77.5 dB, the frequency level of 1 KHz was 77.7 dB, the frequency level of 1250 Hz. was 74.1 dB, the frequency level of 1.6 KHz was 71.4 dB, the frequency level of 2 KHz was 73.4 dB, the frequency level of 2.5 KHz. was 68.9 dB, the frequency level of 3.15 KHz was 68.5 dB, the frequency level of 4 KHz was 69.4 dB, and the frequency level of 5 KHz was 67.3 dB, respectively. (Table 4-15)

Table 4-15 The results of noise attenuation at bottom of machine after the improvement.

Frequency levels	Noise level (dB)					Mean
	No.1	No.2	No.3	No.4	No.5	
Laeq	85.1	85.3	85.3	85.2	85.2	85.2
Lceq	88.6	88.6	88.6	88.6	88.5	88.6
100 Hz	70.5	69.9	70.7	70.0	70.4	70.3
125 Hz	75.0	74.8	74.7	74.6	75.2	74.8
160 Hz	77.0	77.1	76.8	77.1	77.3	77.1
200 Hz	81.7	81.6	81.6	82.2	81.4	81.7
250 Hz	75.6	75.7	76.1	75.7	75.6	75.7
315 Hz	73.6	73.1	74.5	74.4	74.2	74.0
400 Hz	71.7	71.9	71.7	71.7	71.4	71.7
500 Hz	77.2	77.6	77.3	77.0	76.9	77.2
630 Hz	78.8	78.7	78.6	78.8	79.0	78.8
800 Hz	77.3	77.6	77.7	77.3	77.6	77.5
1 KHz	77.5	77.9	77.9	77.6	77.6	77.7
1.25 KHz	74.3	74.1	74.2	73.9	74.3	74.1
1.6 KHz	71.7	71.7	71.4	71.3	71.0	71.4
2 KHz	72.9	73.8	73.5	73.5	73.1	73.4
2.5 KHz	68.7	68.6	68.8	68.9	69.3	68.9
3.15 KHz	68.5	68.0	68.7	68.7	68.6	68.5
4 KHz	69.4	69.3	69.3	69.4	69.4	69.4
5 KHz	67.3	67.3	67.3	67.3	67.2	67.3

4.3.3 A comparison of the noise levels results, both before and after the improvement of the jewelry cleaning machine.

4.3.3.1 A comparison of the noise levels results at the front left of the jewelry cleaning machine between before and after the improvement, it was found that the noise reduction was 4.5 dB(A), 4.9 dB(C) and some frequencies of

noise levels were decreased, particularly was mostly decrease at the frequency of 5 KHz was 9.4 dB. The exception in this case is the frequencies levels of 100 Hz, 125 Hz, 160 Hz, 315 Hz, 400 Hz, 500 Hz, 630 Hz, 800 Hz, 1 KHz, and 1.25 KHz which the noise levels were increased. (Figure C-1)

4.3.3.2 A comparison of the noise levels results at the front left of the jewelry cleaning machine between before and after the improvement, it was found that the noise reduction was 3.6 dB(A), 3.8 dB(C) and some frequencies of noise levels were decreased, particularly was mostly decrease at the frequency of 5 KHz was 7.6 dB. The exception in this case is the frequencies levels of 100 Hz, 125 Hz, 400 Hz, 500 Hz, 630 Hz, 800 Hz, 1 KHz, and 1.25 KHz, and 1.6 KHz which the noise levels were increased. (Figure C-2)

4.3.3.3 A comparison of the noise levels results at the front left of the jewelry cleaning machine between before and after the improvement, it was found that the noise reduction was 8.2 dB(A), 6.6 dB(C) and some frequencies of noise levels were decreased, particularly was mostly decrease at the frequency of 5 KHz was 16.0 dB. The exception in this case is the frequencies levels of 125 Hz, 160 Hz, 500 Hz, 630 Hz, 800 Hz, and 1 KHz which the noise levels were increased. (Figure C-3)

4.3.3.4 A comparison of the noise levels results at the front left of the jewelry cleaning machine between before and after the improvement, it was found that the noise reduction was 6.5 dB(A), 4.6 dB(C) and some frequencies of noise levels were decreased, particularly was mostly decrease at the frequency of 5 KHz was 14.0 dB. The exception in this case is the frequencies levels of 315 Hz, and 630 Hz which the noise levels were increased. (Figure C-4)

4.3.3.5 A comparison of the noise levels results at the front left of the jewelry cleaning machine between before and after the improvement, it was found that the noise reduction was 2.5 dB(A), 0.8 dB(C) and some frequencies of noise levels were decreased, particularly was mostly decrease at the frequency of 5 KHz was 6.5 dB. The exception in this case is the frequencies levels of 200 Hz, 315 Hz, 400 Hz, 500 Hz, 630 Hz, 800 Hz, 1 KHz, and 1.25 KHz which the noise levels were increased. (Figure C-5)

4.3.3.6 A comparison of the noise levels results at the front left of the jewelry cleaning machine between before and after the improvement, it was found that the noise reduction was 0.3 dB(A), 2.6 dB(C) and some frequencies of noise levels were decreased, particularly was mostly decrease at the frequency of 5 KHz was 5.3 dB. The exception in this case is the frequencies levels of 160 Hz, 200 Hz, 250 Hz, 315 Hz, 400 Hz, 500 Hz, 630 Hz, 800 Hz, 1 KHz, and 1.25 KHz which the noise levels were increased. (Figure C-6)

4.3.3.7 A comparison of the noise levels results at the front left of the jewelry cleaning machine between before and after the improvement, it was found that the noise reduction was 10.2 dB(A), 7.9 dB(C) and some frequencies of noise levels were decreased, particularly was mostly decrease at the frequency of 5 KHz was 20.2 dB. The exception in this case is the frequencies levels of 100 Hz and 200 Hz, 315 Hz, 500 Hz, 630 Hz, 800 Hz, and 1 KHz which the noise levels were increased. (Figure C-7)

4.3.3.8 The result of noise levels after installation of sound absorbent material in the jewelry cleaning machine and a comparison of the noise levels, it was found that the noise levels were differ considerably on the frequencies of LAeq, Lceq, 125 Hz, 160 Hz, 200 Hz, 315 Hz, 400 Hz, 630 Hz, 800 Hz, 1.25 KHz, 1.6 KHz, 2 KHz, 2.5 KHz, 3.15 KHz, 4 KHz, and 5 KHz which were statistically significant. ($P = 0.05$) (Table 4-16)

Table 4-16 A comparison of the noise levels results before and after the improvement.

Frequency (dB)	Z	p-value
Laeq	-2.37	0.02
Lceq	-2.37	0.02
100 Hz	-2.37	0.02
125 Hz	-0.42	0.67
160 Hz	-2.37	0.02
200 Hz	-2.37	0.02
250 Hz	-0.34	0.74
315 Hz	-2.37	0.02

Table 4-16 A comparison of the noise levels results, both before and after the improvement.(cont.)

Frequency (dB)	Z	<i>p-value</i>
400 Hz	-2.37	0.02
500 Hz	-1.01	0.31
630 Hz	-2.37	0.02
800 Hz	-2.37	0.02
1 KHz	-0.85	0.40
1.25 KHz	-2.37	0.02
1.6 KHz	-2.37	0.02
2 KHz	-2.37	0.02
2.5 KHz	-2.37	0.02
3.15 KHz	-2.37	0.02
4 KHz	-2.03	0.04
5 KHz	-2.37	0.02

CHAPTER V

DISCUSSION

This research was a quasi-experimental study. The objective was to measure the levels of noise in a workplace area where jewelry cleaning work is processed, and to compare the noise levels between before and after the improvement of noise reduction for the cleaning jewelry in one jewelry processing industry in Bangkok metropolitan. The results of noise reduction were not expected as the following;

1) The original design of jewelry cleaning machine had 2 holes for hand working so the noise can be transmitted directly to the outside.

2) The researcher can't install the sound absorption material on all of the internal parts of the jewelry cleaning machine because the top of the machine is the window glass to monitor the jewelry products while the worker is working with this machine.

3) Determining the noise levels of the jewelry cleaning machine should be done in the laboratory, but it was too expensive to move the machine, other support equipment would need to be installed in the laboratory and because of its effect on production.

4) The work room cannot be protected from noise reflections.

5) The noise source was not only from the jewelry cleaning machine but also from other sources such as the water pump, machine vibration from the machine bed, the fittings or the pipe joints etc.

6) The researcher can't control the noise transmission because the outside of the jewelry cleaning machine did not have sound absorption material.

The potential to reduce noise at each frequency, was based on;

1. The best noise reduction of the sound absorption material was at 5 KHz, it complies with the specification.

2. At some frequencies levels the sound absorption material can reduce the noise level to less than the specification, it does not comply with the specification because it might be affected the machine having 2 hole for hand working in which case be transmitted directly to the outside and the researcher couldn't install the sound absorption material over all of the internals of the jewelry cleaning machine.

3. At frequencies lower than 1000 Hz, the noise increased, it might be caused by resonance while measuring.

CHAPTER VI

CONCLUSION AND RECOMMENDATIONS

6.1 Conclusion

6.1.1 A comparison of the noise levels results at the front left of the jewelry cleaning machine between before and after the improvement, it was found that the noise reduction was 4.5 dB(A), 4.9 dB(C) and some frequencies of noise levels were decreased, particularly was mostly decrease at the frequency of 5 KHz was 9.4 dB. The exception in this case is the frequencies levels of 100 Hz, 125 Hz, 160 Hz, 315 Hz, 400 Hz, 500 Hz, 630 Hz, 800 Hz, 1 KHz, and 1.25 KHz which the noise levels were increased.

6.1.2 A comparison of the noise levels results at the front left of the jewelry cleaning machine between before and after the improvement, it was found that the noise reduction was 3.6 dB(A), 3.8 dB(C) and some frequencies of noise levels were decreased, particularly was mostly decrease at the frequency of 5 KHz was 7.6 dB. The exception in this case is the frequencies levels of 100 Hz, 125 Hz, 400 Hz, 500 Hz, 630 Hz, 800 Hz, 1 KHz, and 1.25 KHz, and 1.6 KHz which the noise levels were increased.

6.1.3 A comparison of the noise levels results at the front left of the jewelry cleaning machine between before and after the improvement, it was found that the noise reduction was 8.2 dB(A), 6.6 dB(C) and some frequencies of noise levels were decreased, particularly was mostly decrease at the frequency of 5 KHz was 16.0 dB. The exception in this case is the frequencies levels of 125 Hz, 160 Hz, 500 Hz, 630 Hz, 800 Hz, and 1 KHz which the noise levels were increased.

6.1.4 A comparison of the noise levels results at the front left of the jewelry cleaning machine between before and after the improvement, it was found that the noise reduction was 6.5 dB(A), 4.6 dB(C) and some frequencies of noise levels were decreased, particularly was mostly decrease at the frequency of 5 KHz was 14.0

dB. The exception in this case is the frequencies levels of 315 Hz, and 630 Hz which the noise levels were increased.

6.1.5 A comparison of the noise levels results at the front left of the jewelry cleaning machine between before and after the improvement, it was found that the noise reduction was 2.5 dB(A), 0.8 dB(C) and some frequencies of noise levels were decreased, particularly was mostly decrease at the frequency of 5 KHz was 6.5 dB. The exception in this case is the frequencies levels of 200 Hz, 315 Hz, 400 Hz, 500 Hz, 630 Hz, 800 Hz, 1 KHz, and 1.25 KHz which the noise levels were increased.

6.1.6 A comparison of the noise levels results at the front left of the jewelry cleaning machine between before and after the improvement, it was found that the noise reduction was 0.3 dB(A), 2.6 dB(C) and some frequencies of noise levels were decreased, particularly was mostly decrease at the frequency of 5 KHz was 5.3 dB. The exception in this case is the frequencies levels of 160 Hz, 200 Hz, 250 Hz, 315 Hz, 400 Hz, 500 Hz, 630 Hz, 800 Hz, 1 KHz, and 1.25 KHz which the noise levels were increased.

6.1.7 A comparison of the noise levels results at the front left of the jewelry cleaning machine between before and after the improvement, it was found that the noise reduction was 10.2 dB(A), 7.9 dB(C) and some frequencies of noise levels were decreased, particularly was mostly decrease at the frequency of 5 KHz was 20.2 dB. The exception in this case is the frequencies levels of 100 Hz and 200 Hz, 315 Hz, 500 Hz, 630 Hz, 800 Hz, and 1 KHz which the noise levels were increased.

6.1.8 The result of noise levels after installation of sound absorbent material in the jewelry cleaning machine and a comparison of the noise levels, it was found that the noise levels were differ considerably on the frequencies of LAeq, LCeq , 125 Hz, 160 Hz, 200 Hz, 315 Hz, 400 Hz, 630 Hz, 800 Hz, 1.25 KHz, 1.6 KHz, 2 KHz, 2.5 KHz, 3.15 KHz, 4 KHz, and 5 KHz which were statistically significant. (P = 0.05)

6.2 Recommendations

6.2.1 The results of noise level from this experiment were from multiple sources in the process. So the further study should be done at the other noise source.

6.2.2 Although the jewelry cleaning machine can reduce noise levels, a continual engineering or design the soundproof cleaning machine.

REFERENCES

- 1 Ministerial regulation determines the standardization in administration and management in occupational health and workplace environment related to heat light and sound, 2006
- 2 National Institute for Occupational Safety and Health. [NIOSH] (1998). Criteria for a recommended standard: Occupational noise exposure revised criteria 1998. Ohio: U.S. Department of Health and Human Services.
- 3 The report on current and trend of Thailand's occupational health problems by occupational health department of the Ministry of Public Health, 1995
- 4 National Occupational Research Agenda [NORA], (2001). Hearing loss. Retrieved February 4, 2004, from <http://www.cdc.gov/niosh/nrhear.html>
- 5 Social Security Office (Thailand), Annual Report of Social Security Office, (2012)
- 6 Pornpimol Kongtip, (2012) Industrial Hygiene.
- 7 Henry W.Ott, (1988). Noise reduction techniques in electronic systems.
- 8 The standard IEC 651 Type 2 (international Electrical Commission 651 Type 2) Trademark CASELLA Model CEL – 6X0
- 9 American Industrial Hygiene Association, Industrial noise manual 2nd edition, (1996)
- 10 National Institute for Occupational Safety and Health. Criteria for a recommended standard: Occupational exposure to noise. Cincinnati, Ohio: National Institute for Occupational Safety and Health, (1972)
- 11 Lusk SL. Noise exposure: Effects on hearing and prevention of noise induced hearing Loss. AAOHN, 1997
- 12 Willeam Siekman, Joseph W. (1976). Sullivan Acoustic absorption and transmission – loss material. In : L.L. Faulkner, editor. Handbook of industrial noise control : Industrial Press Inc., New York.

- 13 World Health Organization, (2004). Protection of the Human Environment, Assessing the burden of disease from work-related hearing impairment at national and local levels.
- 14 ASTM E-1050, (1992) Standard test method for impedance and absorption of acoustical materials using a tube, two microphone, and a digital frequency analysis system. Philadelphia: American Society for Testing and Materials.
- 15 Wichai Rairat, (2003) Design and fabrication of plenum chamber silencer for noise attenuation.
- 16 Le Prell CG, Dolan DF, Schacht J, Miller JM, Lomax MI, Altschuler RA., (2003) Pathways for protection from noise induced hearing loss. Noise & health.
- 17 Le Prell CG, Yamashita D, Minami SB, Yamasoba T, Miller JM., (2007). Mechanisms of noise-induced hearing loss indicate multiple methods of prevention. Hearing research.
- 18 Supaporn Tarnpeam, Chawapornpan Chanprasit, and Wanpen Songkham, (2007). Hearing Capacity and Noise Hazard Preventive Behaviors Among Workers in Sugar Refinery Factory, Nursing Journal Volume 34 Number 4 October - December 2007
- 19 McCreynolds, C. M., (2005). Noise Induce Hearing Loss. Air medical Journal, 24(2), 73-78
- 20 Arnon Kachaprasert, (2009). Hearing loss and Occupational Noise Exposure among workers in wing 46 airport ground service, RTAF.
- 21 Napol Gieatgongmanee, (2010). How to apply the used of sound absorbent material to its maximum efficiency, Built Environment Research Associates' Conference I.
- 22 Scotly John Wertel, (2000). Experimental Analysis of Noise Reduction Properties of Sound Absorbing foam, The Graduate College University of Wisconsin-Stout May, 2000
- 23 Issada Kaewprasert, (1996). Improving noise reduction performance of concrete block with ventilation gap.

APPENDICES

APPENDIX A

THE JEWELRY CLEANING MACHINE

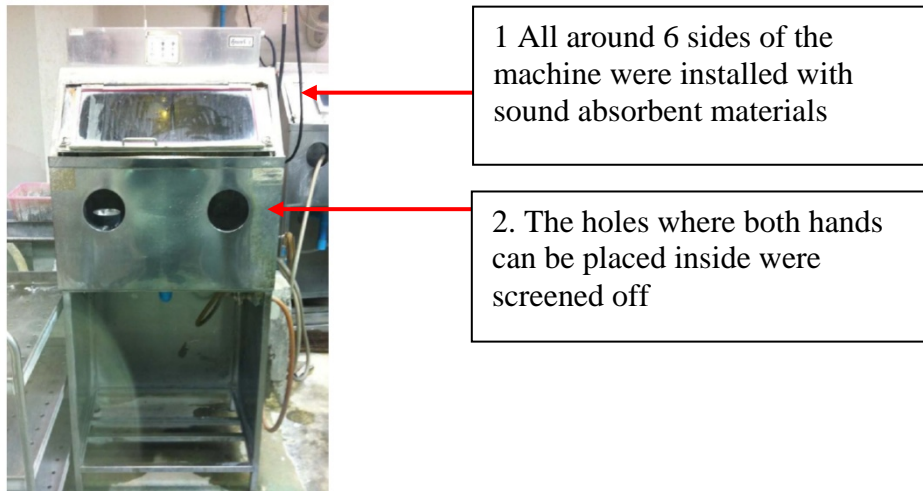

Figure A-1 The jewelry cleaning machine.

APPENDIX B NOISE MEASUREMENTS

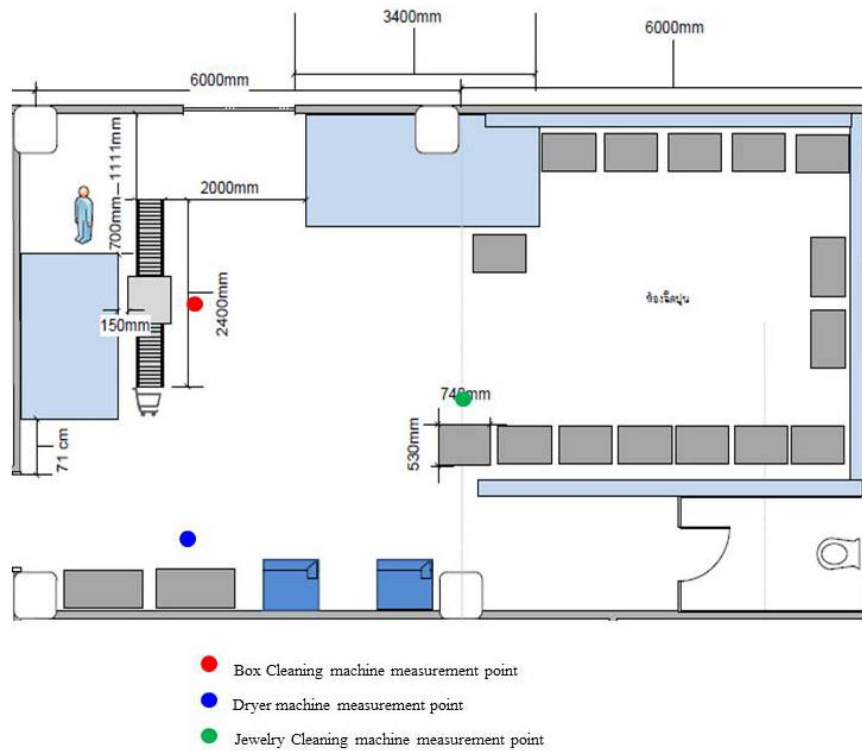

Figure B-1 Noise monitoring layout at cleaning process



Figure B-2 Sound meter level type2 Model Casella Series CEL-6X08⁸



Figure B-3 Noise monitoring at Cleaning box machine.



Figure B-4 Noise monitoring at cleaning machine.



Figure B-5 Noise monitoring at cleaning machine at front of machine.



Figure B-6 Installation absorber material inside of Jewelry cleaning machine.

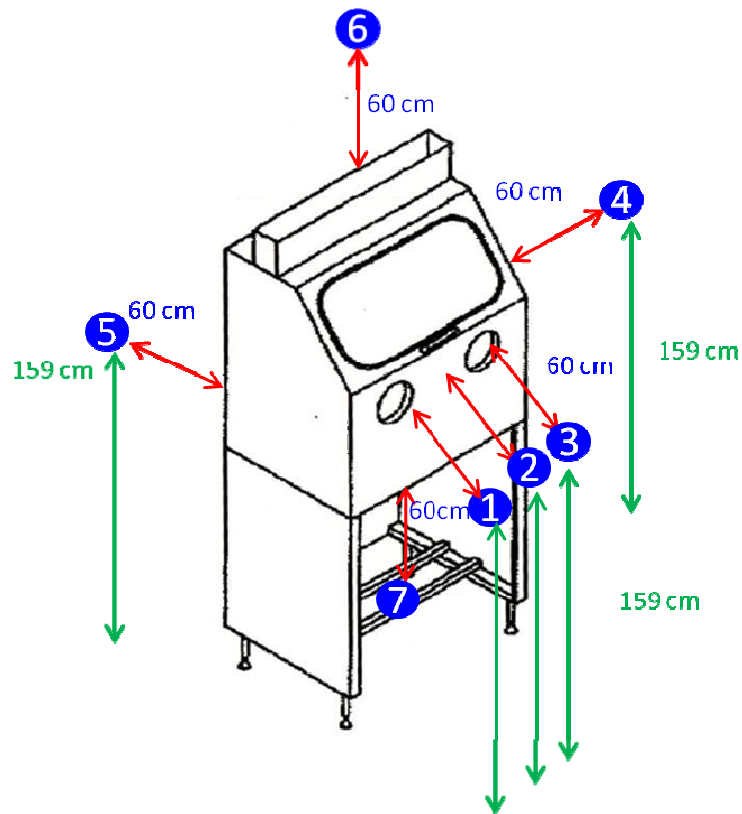

Figure B-7 The monitor point of cleaning machine



Figure B-8 Noise monitor at lift of the middle of jewelry cleaning machine



Figure B-9 Noise monitor at middle of Jewelry Cleaning machine



Figure B-10 Noise monitor at right of the middle of Jewelry Cleaning machine



Figure B-11 Noise Monitor at beside of Jewelry cleaning machine



Figure B-12 Noise Monitor at back of the middle of Jewelry cleaning machine



Figure B-13 Noise Monitor at above of Jewelry cleaning machine



Figure B-14 Noise Monitor at right of the middle of Jewelry cleaning machine

APPENDIX C

RESULT OF SOUND LEVELS MEASUREMENT

(dB)

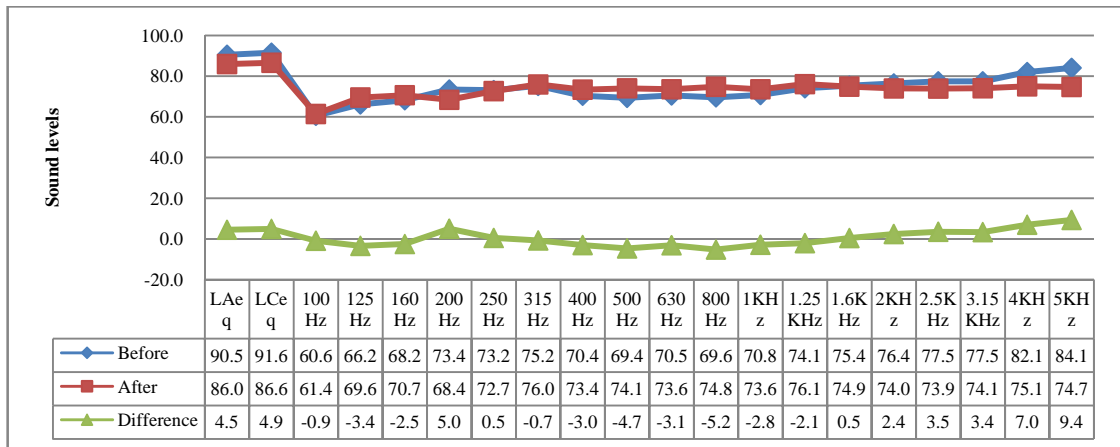

Figure C-1 The Comparison result of the before and after improvement the jewelry cleaning machine that monitor at front of machine .

(dB)

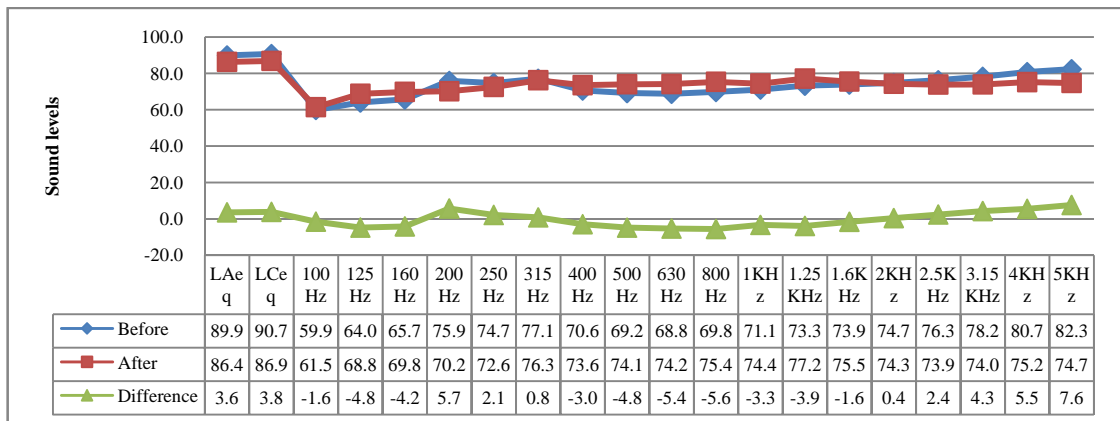

Figure C-2 The Comparison result of the before and after improvement the jewelry cleaning machine that monitor at front of machine (Middle).

(dB)

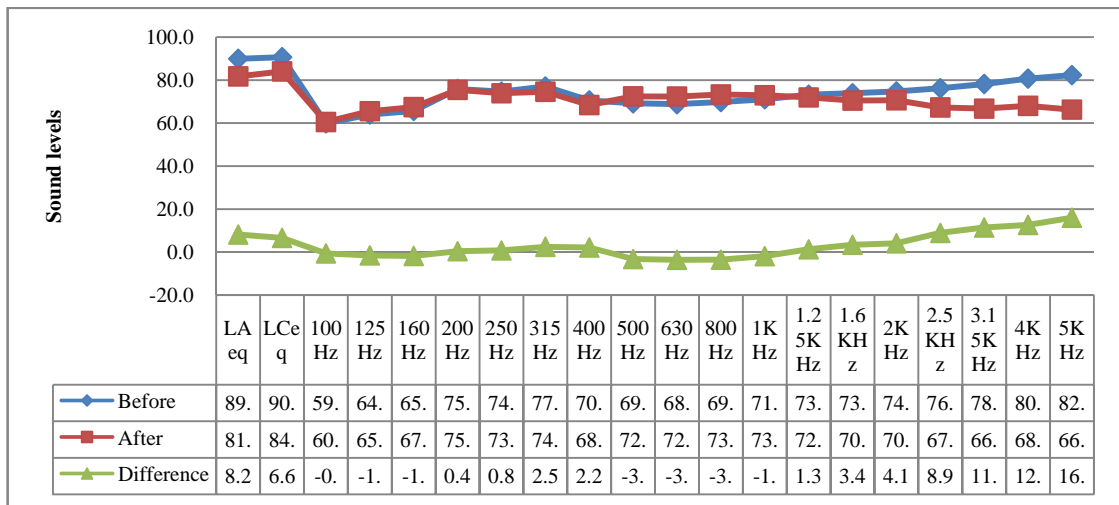

Figure C-3 The Comparison result of the before and after improvement the jewelry cleaning machine that monitor at front of machine (Right).

(dB)

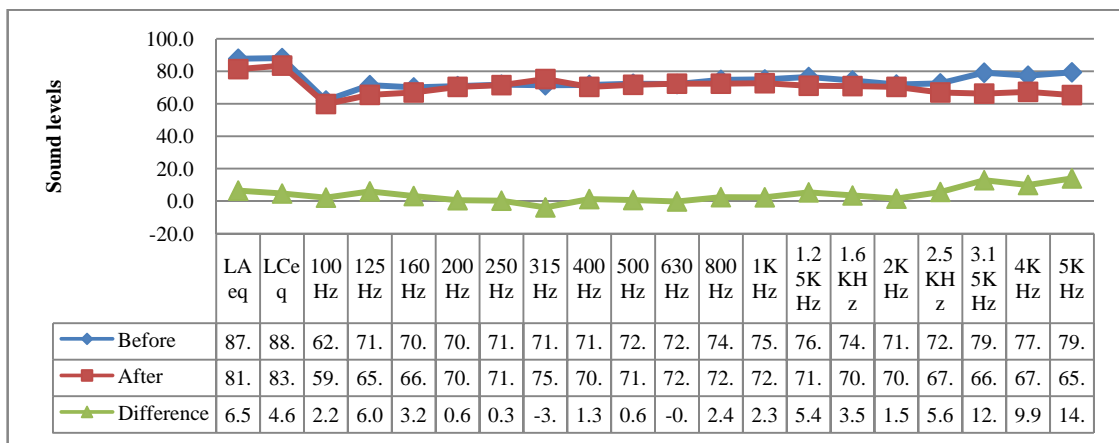

Figure C-4 The Comparison result of the before and after improvement the jewelry cleaning machine that monitor at Beside of machine.

(dB)

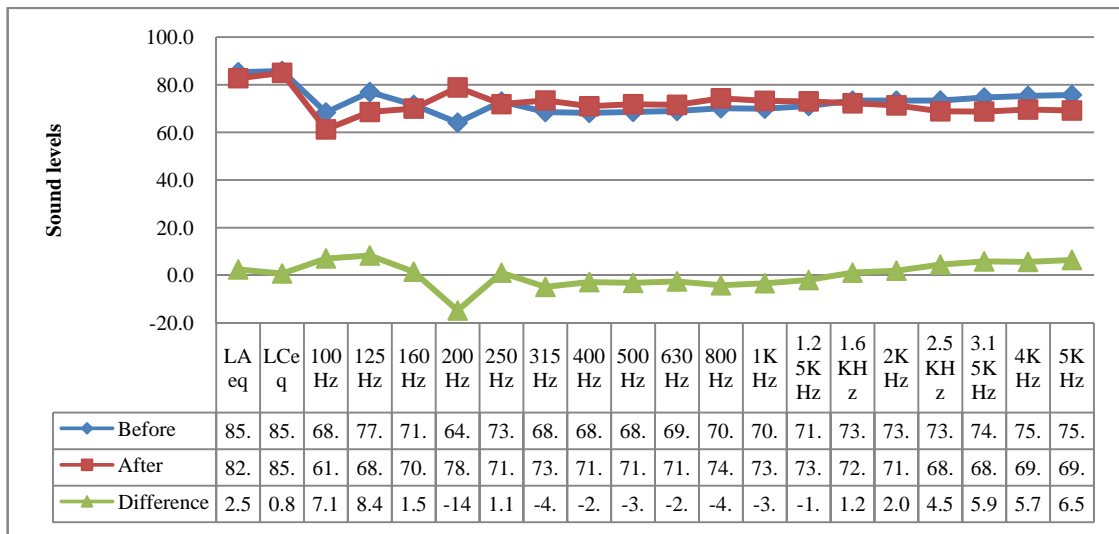

Figure C-5 The Comparison result of the before and after improvement the jewelry cleaning machine that monitor at at Rear of machine.

(dB)

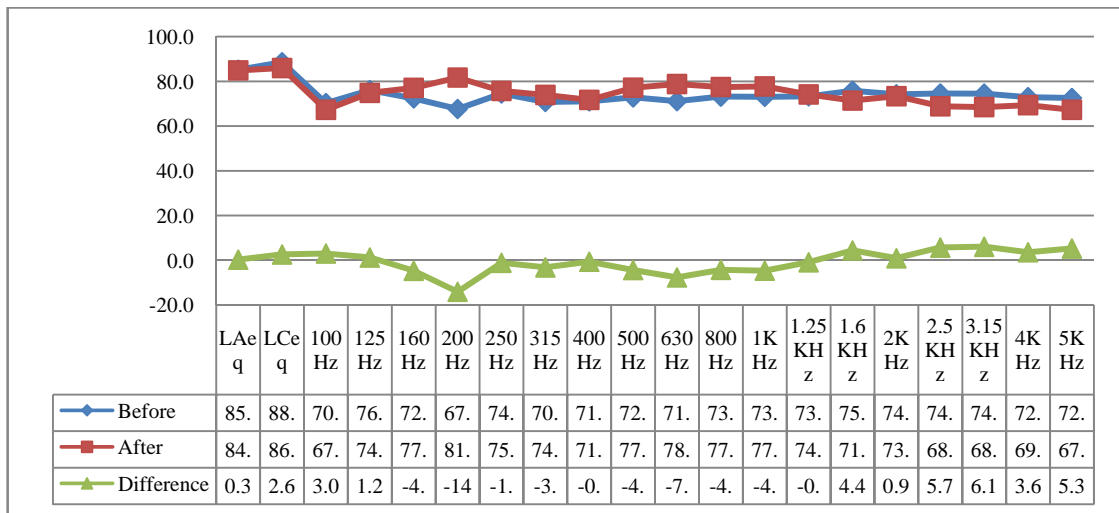

Figure C-6 The comparison result of the before and after improvement the jewelry cleaning machine that monitor at Above of machine.

(dB)

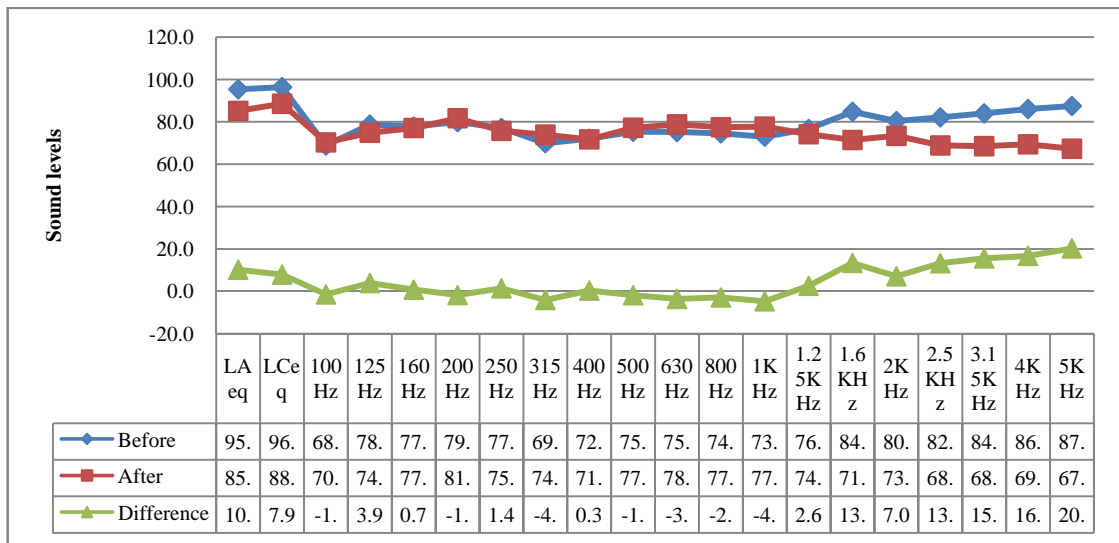

Figure C-7 The comparison result of the before and after improvement the cleaning jewelry machine that monitor.

BIOGRAPHY

NAME	Miss Jaruwan Ladorndoo
DATE OF BIRTH	30 January 1984
PLACE OF BIRTH	Buriram, Thailand
INSTITUTION ATTENDED	Khonkaen University, 2002-2006 Bachelor of Science (Environmental health) Sukhothai Thammathirat Open University, 2008-2010 Bachelor of Public Health (Occupational Health and Safety) Mahidol University, 2012-2015 Master of Science (Occupational Health and Safety)
POSITION & OFFICE	EHS Officer Pandora Production Co., Ltd. 88 Soi Sukhapibal 2 Soi 31, Dokmai, Pra Vet, Bangkok 10250 Tel. 02-881-0650-6 E-mail : jaruwan_pui30@hotmail.com
HOME ADDRESS	14/403 Niran Vill 10, Bangchalong, Bangplee, Samutprakarn 10540 Tel.080-5664759 E-mail : jaruwan_pui30@hotmail.com