

Appendix A

Methods for producing nanofluids

Measurement of thermal conductivity

Methods for producing nanofluids

The two techniques that are commonly used to make nanofluids (Jayageeth, 2005):

1. Two-step process (Kool-Aid method):

Nanoparticles are produced by inert-gas condensation or Chemical Vapor Deposition and then dispersed into a base fluid in a second processing step. Simple techniques such as ultrasonic agitation or the addition of surfactants to the fluids are sometimes used to minimize particle aggregation and improve dispersion behavior. This method works well for oxide nanoparticles.

2. One-step process:

Single-step nanofluid processing methods have also been developed. For example, nanofluids containing dispersed metal nanoparticles have been produced by a 'direct evaporation' technique. As with the inert gas condensation technique, this involves the vaporization of a source material under vacuum conditions. An advantage of this technique is that nanoparticle agglomeration is minimized, while a disadvantage is that only low vapor pressure fluids are compatible with the process. The thermal conductivity of the nanofluid varies as a function of nanoparticle loading.

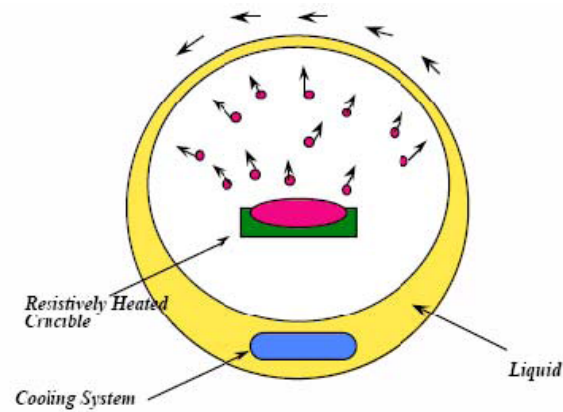

Figure Appendix A1 Production system designed for direct evaporation/condensation of NPs into low vapor pressure liquids

Sources: Jayageeth (2005)

Measurement of thermal conductivity

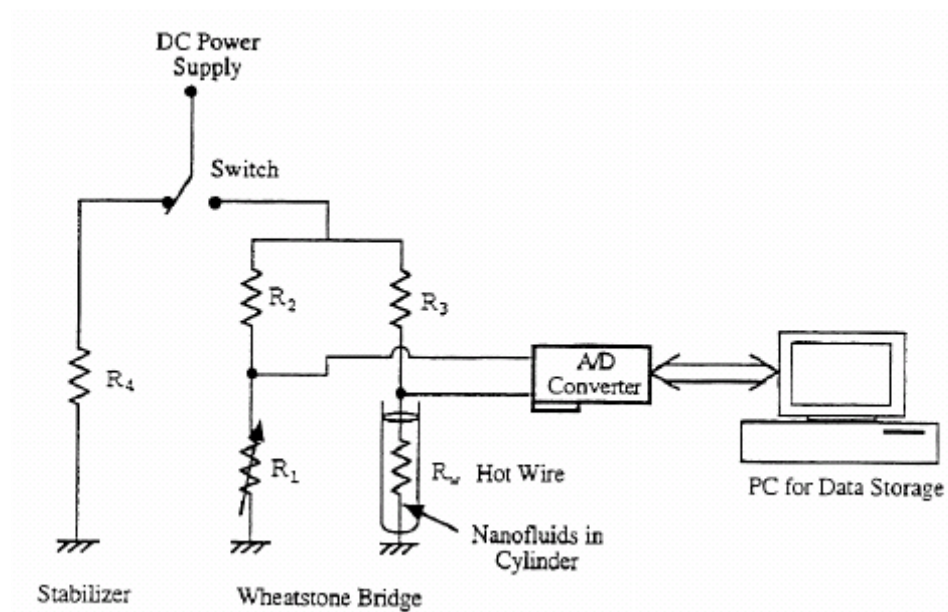

Figure Appendix A2 Schematic diagram of a transient hot-wire apparatus

Source: Xuan and Li (2000)

Transient Hot-Wire Method:

This method (Xuan and Li, 2000) is one of the most accurate ways to determine fluids thermal conductivity. The advantage of this method is its almost complete elimination of the effects of natural convection. The governing equation is:

$$T(t) - T_{ref} = \frac{q}{4\pi k} \ln\left(\frac{4K}{a^2 C} t\right)$$

where $T(t)$ is the temperature of the wire in the fluids at time t , is the temperature of the cell, q is the applied electric power, k is the thermal conductivity, K is the thermal diffusivity of the fluid, a is the radius of the wire, and $\ln C = g$, where g is Euler's constant. The relationship given by Eq. (12) presents a straight line for a plot of δT versus $\ln(t)$. The slope of the δT versus $\ln(t)$ relationship is obtained between times t_1 and t_2 and here, equation to calculate thermal conductivity is obtained:

$$k = \frac{q}{4\pi(T_2 - T_1)} \ln\left(\frac{t_2}{t_1}\right)$$

where $T_2 - T_1$ is the temperature rise of the wire between times t_1 and t_2 . From the temperature coefficient of the wire's resistance, the temperature rise of the wire can be determined by the change in its electrical resistance as the experiment goes on.

Despite the advantages of the transient hot-wire methods, it is impossible to measure the thermal conductivity of electrically conducting fluids because current flows through the liquids, the heat generation of the wire becomes ambiguous, and polarization occurs on the wire's surface. This method is thus normally restricted to electrically non-conducting fluids such as noble gases and organic liquids. There have been only a few attempts to expand the transient hot-wire method to measure electrically conducting liquids