

# **DYNAMIC ANALYSIS OF BRIDGES WITH PLASTIC HINGES UNDER EXTREME EARTHQUAKES**

T. Y. LEE and K. J. CHUNG

*National Central University, Taoyuan County, Taiwan*

This study is aimed to develop the model of fiber element in the Vector Form Intrinsic Finite Element (VFIFE) to analyze the plastic hinges of reinforced-concrete columns for bridges subjected to extreme earthquakes. The VFIFE, a new computational method, is adopted in this study because of the superior in managing the engineering problems with material nonlinearity, discontinuity, large deformation and arbitrary rigid body motions of deformable bodies. In the past study, a plastic hinge is idealized as a bilinear elastoplastic model with a fracture moment. In order to analyze the realistic behavior of the plastic hinge, especially in ultimate state, the fiber element is developed to simulate the plastic hinge by using stress-strain relations in cover concrete, core concrete and steel fibers. The developed fiber element is verified to be feasible and accurate through numerical simulation. A three-span-continuous isolated bridge is analyzed to investigate the function of the columns and unseating prevention devices and to predict the collapse situation of the whole bridge. In addition, the analysis results are compared between the fiber element and bilinear elastoplastic element.

*Keywords:* 3D VFIFE, Fiber Element, Ultimate State, Bridge.

## **1 INTRODUCTION**

Nonlinear dynamic analysis of structural models has been extensively used to assess the seismic performance of existing structures and then to determine appropriate retrofit strategies. Nowadays a number of modelling strategies have been developed for the study of the global, regional and local hysteretic response of buildings and bridges under strong ground motions. Since the inelastic behaviour of reinforced concrete (RC) structures often concentrates at the ends of girders and columns, an early approach to model this behaviour was by means of non-linear springs located at the member ends. However, there are some limitations in lumped plasticity constitutive models to simulate the hysteresis behavior of RC structures more precisely (Charney and Bertero 1982, Bertero *et al.* 1984).

This study is intended to develop the fiber element model proposed by Spacone *et al.* (1996) in Vector Form Intrinsic Finite Element (VFIFE) method to analyze the plastic hinges of reinforced-concrete columns for bridges subjected to extreme earthquakes. A three-span-continuous isolated bridge is analyzed to investigate the plastic hinges of the columns and the function of unseating prevention devices, finally to predict the collapse situation of the whole bridge.

## 2 VECTOR FORM INTRINSIC FINITE ELEMENT

The Vector Form Intrinsic Finite Element is developed based on theory of physics to simulate the failure responses of structural systems, in particular under seismic loading. The first step in the VFIFE analysis is to construct a discrete model for a continuous structure by using a lumped-mass idealization. It is noted that all lumped masses are connected by deformable elements without mass. Then applying Newton's Second Law of Motion, the equations of motion are established at each mass for all degrees of freedoms. Assume that a structural system consists of a finite number of lumped masses. A mass designated as  $\alpha$  has a diagonal mass matrix  $\mathbf{M}^\alpha$  and a displacement vector  $\mathbf{d}^\alpha(t)$  at time  $t$ . The equations of motion for mass  $\alpha$  are written as

$$\mathbf{M}^\alpha \ddot{\mathbf{d}}^\alpha(t) = \mathbf{P}^\alpha(t) - \mathbf{f}^\alpha(t) \quad (1)$$

where  $\mathbf{P}^\alpha$  are the applied forces or equivalent forces acting on this mass;  $\mathbf{f}^\alpha$  are the total resisting forces or internal resultant forces exerted by all the elements connecting with this mass. Note that each element without mass in the VFIFE is assumed to be in static equilibrium. Observed from Eq. (1), it is not necessary to assemble the global stiffness matrix for structures with multiple degrees of freedom in the VFIFE analysis. A matrix algebraic operation for the entire system is waived. Instead, each equation of motion for each particle, Eq. (1), can be individually solved. Since the failure progress of structures involves changes in material properties and structural configuration, discrete time domain analysis is used to solve the equations of motion. The central difference method, an explicit time integration method, is adopted to solve the equations of motion, Eq. (1). Compared to the traditional finite elements, the feature of the VFIFE is that element internal forces are calculated by deformations of elements through subtracting rigid body motion from total displacements. Therefore, a set of deformation coordinates are defined for each element in each time increment. The VFIFE is capable of dealing with large displacements, deformations and rigid body motion simultaneously.

## 3 FIBER ELEMENT MODEL

A beam element without rigid body modes is shown in Figure 1 in the local coordinates  $xyz$ . The element is divided into a number of discrete cross-sections. The formulation of the beam element is based on the assumption of linear geometry. During the history of element deformation, plane sections remain plane which is normal to the longitudinal axis.

Figure 1 shows the fibers of the cross sections. Each section is subdivided into  $n$  fibers, where  $n$  is a function of  $x$  to consider the variation of both cross-section dimensions and longitudinal reinforcements along the element. The section stiffness is determined by integrating the related properties of each fiber while the resisting force by integrating the corresponding stresses of each fiber. Figure 2 shows the generalized element forces  $\mathbf{Q}$  and the corresponding deformations  $\mathbf{q}$ . Also, the section forces  $\mathbf{D}$  and corresponding deformations  $\mathbf{d}$  are shown in Figure 2. The vector components of  $\mathbf{Q}$ ,  $\mathbf{q}$ ,  $\mathbf{D}$ ,  $\mathbf{d}$  are written as below.

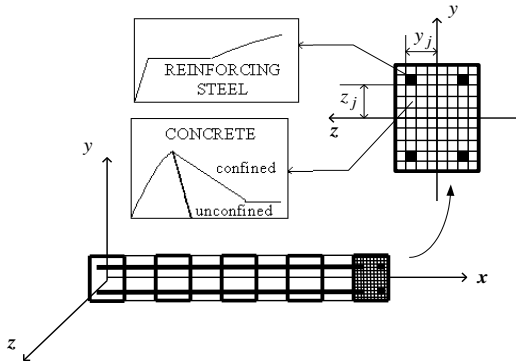

Figure 1. Beam element in the local reference system: subdivision of cross-section into fibers.

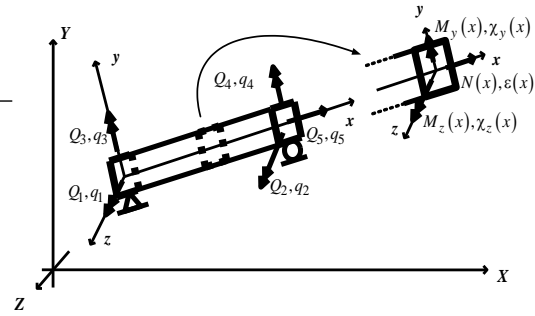

Figure 2. Generalized Element forces and deformations at the element and section level.

$$\mathbf{Q} = [Q_1 \quad Q_2 \quad Q_3 \quad Q_4 \quad Q_5]^T \quad (2)$$

$$\mathbf{q} = [q_1 \quad q_2 \quad q_3 \quad q_4 \quad q_5]^T \quad (3)$$

$$\mathbf{D}(x) = [M_z(x) \quad M_y(x) \quad N(x)]^T \quad (4)$$

$$\mathbf{d}(x) = [\chi_z(x) \quad \chi_y(x) \quad \varepsilon(x)]^T \quad (5)$$

$\chi_y(x)$  and  $\chi_z(x)$  denote the section curvature about  $y$  and  $z$  axes, respectively, and  $\varepsilon(x)$  denotes the axial strain in the  $x$  direction. On the assumptions mentioned above, the fiber strains can be obtained from the section deformations by using a simple geometric transformation matrix. Since the member behaviour in torsion is assumed to remain linear elastic and uncoupled from the flexural and axial response, the element force and deformation vectors in Eqs. (2) and (3), respectively, do not include torsional force and deformation.

The beam element is formulated by the two-field mixed method. The matrix relation between element generalized forces and corresponding deformations is derived by using the integral form of equilibrium and section force-deformation relations. The section force-deformation relation is linearized about the present state and an iterative algorithm is used to satisfy the non-linear section force-deformation relation within the required tolerance. The detailed formulations and their derivations can be found in the related studies.

## 4 NUMERICAL SIMULATION

### 4.1 Target Bridge

A three-span-continuous isolated bridge is analyzed, as shown in Figure 3 by using VFIFE with fiber elements. The bridge has a five-span deck with a total length of

5@40 m=200 m and a width of 12 m, which is supported by four reinforced concrete columns with a height of 12.2 m in each and two abutments. The columns are idealized by two different models. One is a perfect elastoplastic model with a fracture ductility of 21.5. The other is a fiber element model with the material behavior of core concrete, cover concrete and steel proposed by Filippou *et al.* (1983) as shown in Figure 4.

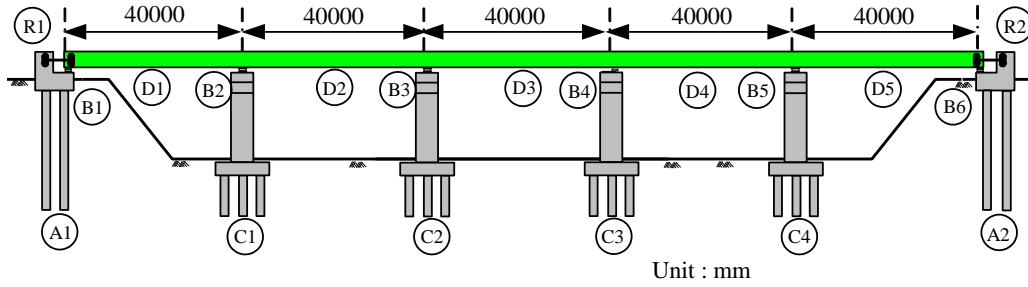

Figure 3. Five-spans continuous isolated bridge model.

#### 4.2 Ultimate State of Bridge

The input ground motion in simulation was recorded at JMA Kobe, 1995. Figure 5 depicts the failure procedure of the continuous bridge adopting the bilinear springs to consider the plastic hinges under 290% of JMA Kobe ground motion, where the first characters B, C, D and R of the notions denote the isolators, column, deck and tendon, respectively. First of all, the isolators B2-B4 fractured along the way perpendicular to bridge axis and also the tendons fractured. Then the columns C1, C2, C3 and C4 collapsed when it reached the ultimate ductility, which resulted in the unseating of decks D1, D2, D3 and D4. Figure 6 depicts the failure procedure of the continuous bridge adopting the fiber elements to consider the plastic hinges under 290% of JMA Kobe ground motion. Figure 7(a) shows the hysteretic loops of columns adopting bilinear springs. Figure 7(b) shows the hysteretic loops of columns adopting fiber elements. According to the analytical results, while the columns reached the ductility,

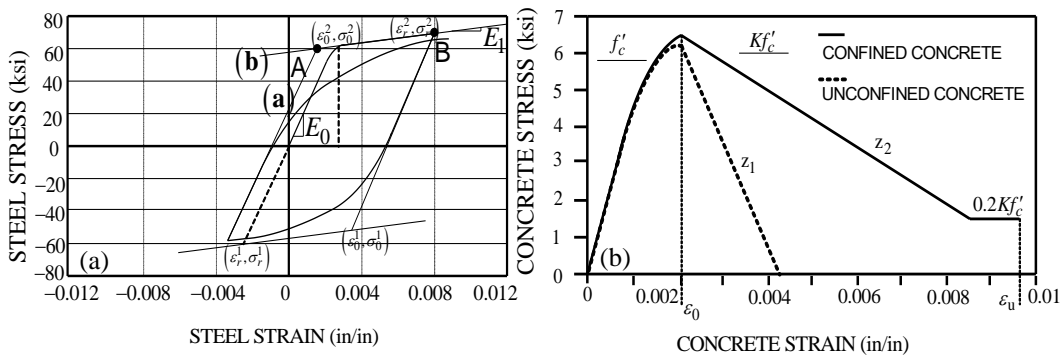

Figure 4. Hysteretic stress-strain relation of (a) steel, (b) concrete.

the case adopting fiber element could still consider the resistant force applied by core concrete which prevented the superstructure of bridge from unseating immediately. Therefore, utilizing the fiber element to simulate the plastic hinge of column is more accurate and closed to the real situation.

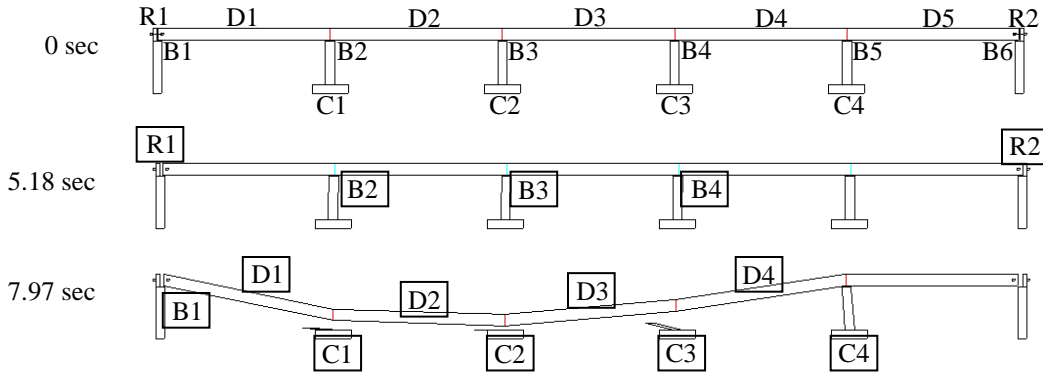

Figure 5. Failure process of the bridge adopting bilinear spring element under 290% of JMA Kobe records.

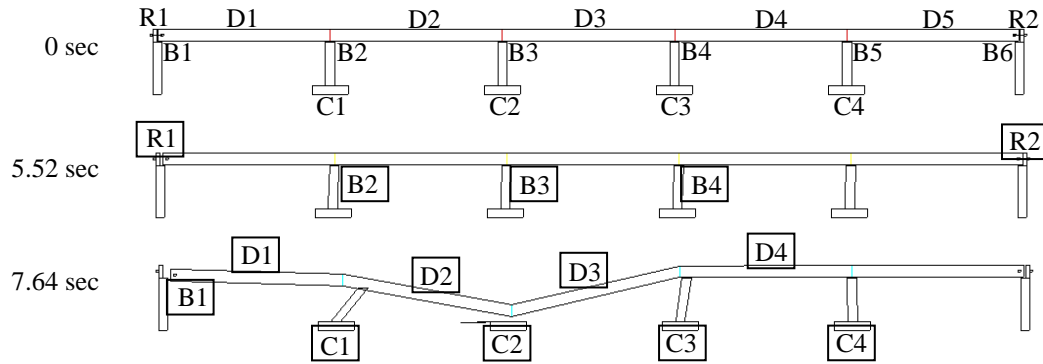

Figure 6. Failure process of the bridge adopting fiber element under 290% of JMA Kobe records.

## 5 CONCLUSIONS

- The fiber element is developed in VFIFE to simulate the hysteretic behaviour of column of isolated bridge under extreme earthquake successfully. The fiber element developed in VFIFE is particularly suitable for the analysis of the highly non-linear hysteretic behaviour of softening members, such as reinforced concrete columns under extreme earthquakes.
- Due to the material model considered in the fiber element, while the column reached the ductility, the superstructure of bridge would not collapse immediately. Even the steels had fractured; the core concrete still applied the

resistant force for column. Comparatively, the bilinear spring model in VFIFE would set the resistant force to be zero while the ductility was achieved that causing the unseating of deck to happen simultaneously.

- Compared with the bilinear spring, adopting the fiber element to simulate the plastic hinges of columns could predict the non-linear behaviour of substructure of bridge more accurately. The bilinear spring in VFIFE simulated the responses of column in three-dimensional model including axial force, shear, moment and torsion independently, however, the axial and rotational response are coupled.

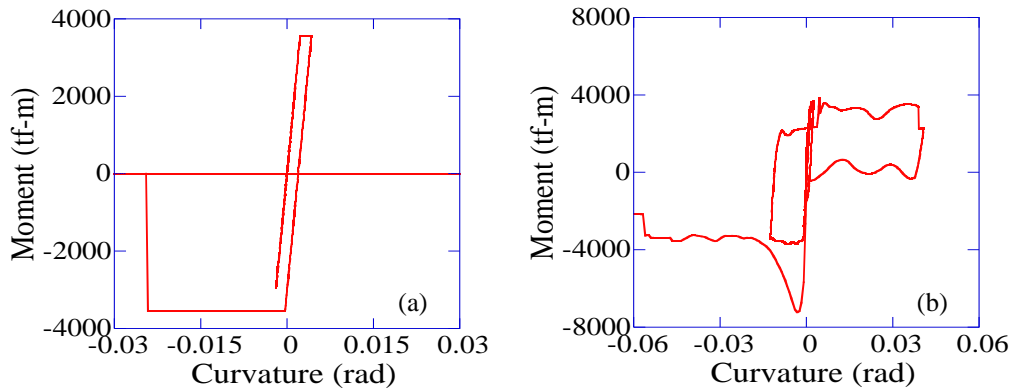

Figure 7. Hysteretic loop of column C1 simulated by (a) bilinear spring element (b) fiber element.

## References

- Bertero, V. V., Aktan, A., Charney, F., and Sause, R., Earthquake Simulator Tests and Associated Experimental, Analytical and correlation Studies of One-Fifth Scale Model, *Earthquake Effects on Reinforced Concrete Structures*, American Concrete Institute, SP-84-13, 375-424, Detroit, 1984.
- Charney, F., and Bertero, V. V., An Evaluation of the Design and Analytical Seismic Response of a Seven Storey Reinforced Concrete Frame-Wall Structure, *EERC Report 82/08*, Earthquake Engineering Research Center, University of California, Berkeley, 1982.
- Filippou, F. C., Popov, E. P., and Bertero, V. V., Effects of Bond Deterioration on Hysteretic Behavior of Reinforced Concrete Joints, *EERC Report 83/19*, Earthquake Engineering Research Center, University of California, Berkeley, 1983.
- Spacone, E., Filippou, F. C., and Taucer, F. F., Fibre Beam-Column Model for Non-Linear Analysis of R/C Frames: Part I. Formulation, *Earthquake Engineering and Structural Dynamics*, 25(7), 711-725, Jul, 1996.
- Ting, C., Shih, C., and Wang, Y.K., Fundamentals of a Vector Form Intrinsic Finite Element: Part I. Basic Procedure and a Plane Frame Element, *Journal of Mechanics*, 20, 113-122, 2004.